

Cap N2408

INCH OD Tubes

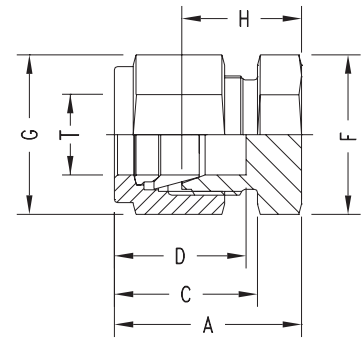

Part No.	T Tube OD	A	C	D	F A/F	G A/F	H
N2408-01	1/16	13.0	11.0	8.6	11	8	11.2
N2408-02	1/8	20.0	15.3	12.7	11	11	13.5
N2408-04	1/4	23.4	17.8	15.3	14	14	16.0
N2408-05	5/16	24.4	18.5	16.3	16	16	17.0
N2408-06	3/8	25.7	19.3	16.8	17	17	18.3
N2408-08	1/2	29.2	21.8	22.9	22	22	19.0
N2408-10	5/8	30.0	21.8	24.4	24	25	19.8
N2408-12	3/4	31.5	21.8	24.4	27	28.5	21.4
N2408-14	7/8	34.0	21.8	25.9	35	32	23.9
N2408-16	1	38.4	26.4	31.2	35	38	26.2
N2408-20	1-1/4	53.3	38.9	41.2	46	50	31.2
N2408-24	1-1/2	64.5	45.2	50.0	55	57	37.4
N2408-32	2	88.6	62.7	67.6	70.0	76.0	49.3

Butt Weld Male Connector N2425

INCH OD Tubes To Pipe

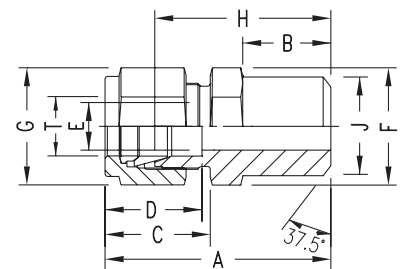

Part No.	T Tube OD	Pipe Weld Male	A	B	C	D	E min.	F A/F	G A/F	H	J
N2425-02-02	1/8	1/8	30.5	9.6	15.3	12.7	2.4	11	11	23.9	10.3
N2425-04-02	1/4	1/8	32.8	9.6	17.8	15.3	4.8	14	14	25.4	10.3
N2425-04-04	1/4	1/4	37.8	14.3	17.8	15.3	4.8	14	14	30.5	13.7
N2425-05-02	5/16	1/8	34.0	9.6	18.5	16.3	5.1	14	16	26.7	10.3
N2425-05-04	5/16	1/4	38.6	14.3	18.5	16.3	6.3	16	16	31.2	13.7
N2425-06-04	3/8	1/4	39.9	14.3	19.3	16.8	7.1	16	17	32.5	13.7
N2425-06-06	3/8	3/8	39.9	14.3	19.3	16.8	7.1	17	17	32.5	17.2
N2425-06-08	3/8	1/2	46.3	19.1	19.3	16.8	7.1	22	17	38.9	21.3
N2425-08-06	1/2	3/8	43.4	14.3	21.8	22.9	10.4	22	22	33.3	17.2
N2425-08-08	1/2	1/2	49.0	19.1	21.8	22.9	10.4	22	22	38.9	21.3
N2425-08-12	1/2	3/4	50.5	19.1	21.8	22.9	10.4	27	22	40.4	26.7
N2425-10-08	5/8	1/2	49.0	19.1	21.8	24.4	12.7	24	25	38.9	21.3
N2425-12-12	3/4	3/4	50.5	19.1	21.8	24.4	15.8	27	29	40.4	26.7
N2425-16-16	1	1	62.2	23.8	26.4	31.2	22.3	35	38	50.0	33.4
N2425-20-20	1-1/4	1-1/4	77.2	23.8	38.9	41.2	27.6	46	50	55.2	42.2
N2425-24-24	1-1/2	1-1/2	88.9	26.2	45.2	50.0	34	55	60	61.7	48.3