



POSITIVE DRIVE PD™

TIMING SPROCKET DIMENSIONS

SYNCHRONOUS

The timing sprockets for XL Positive Drive Pd belts are all carried in stock with a minimum plain bore only but can be re-bored to any size within the bore range. Constructions are available with solid (no web) or with web. Sprockets are also available with or without flanges.

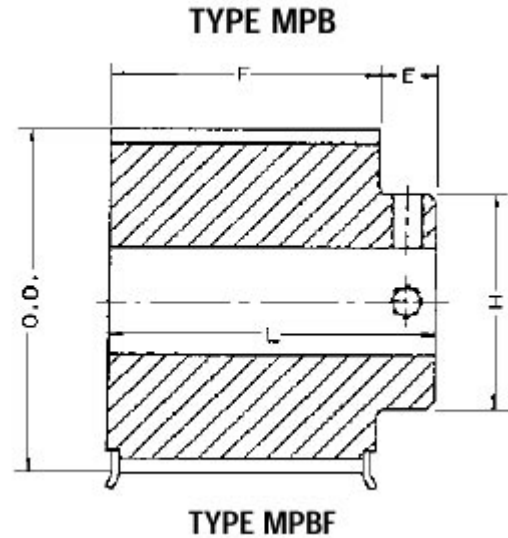

SPROCKET TYPES

The following types of sprockets are available for Positive Drive Pd belts. Sketches are shown with the Sure-Grip¹ bushing in place. Sprockets are available either solid, with webs, or with arms. They are also available with or without flanges.

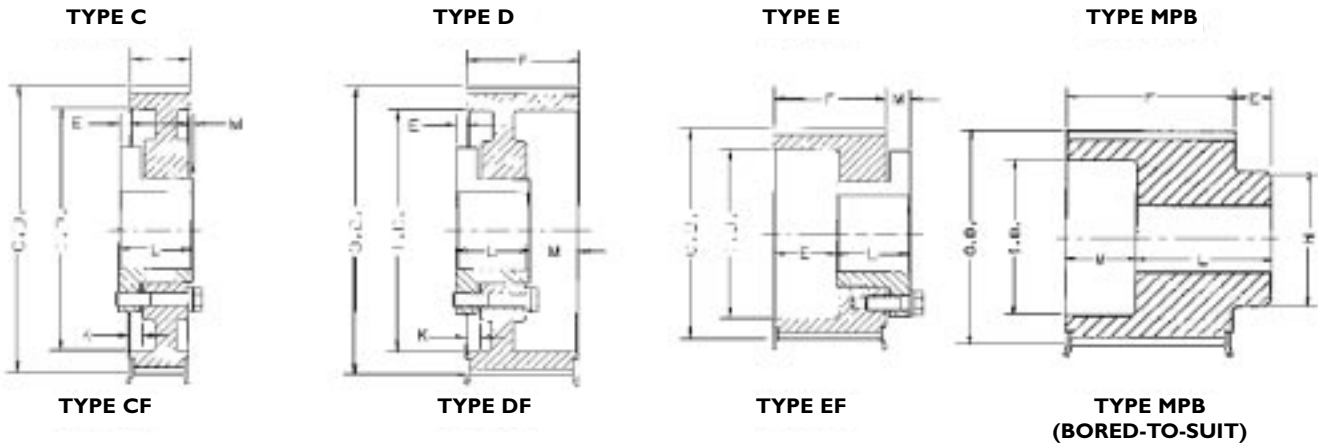

Note: Above sprockets are available for L, H, XH, and XXH belts.

FOR FULL PRODUCT AVAILABILITY AND SPECIFICATIONS,
PLEASE VISIT WWW.GOODYEARPTR.COM OR CONTACT A GOODYEAR REPRESENTATIVE.

¹SURE-GRIP is a registered trademark of TB WOOD'S Incorporated