

BRASS SWING CHECK VALVES

VALVES

- Working pressure non-shock: 200 psi W.O.G. (cold water, oil, gas) 125 psi WSP (saturated steam)
- Swing type disc.
- Screwed Cap.
- Hard Seat.
- 90° Straight Pattern.

- Used to prevent reverse flow in commercial and industrial applications.
- Threaded ends to ANSI B1.20.1
- Integral seat.

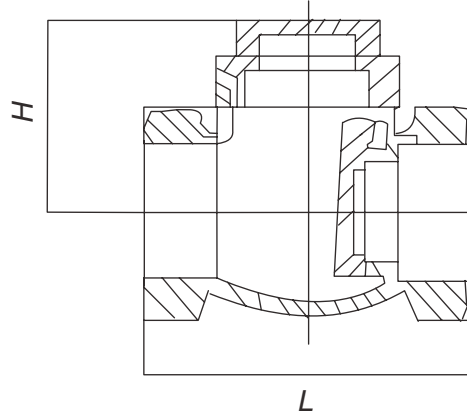

CAST BRASS SWING CHECK VALVES IPS SCREWED ENDS

Part #	Size	H	L	Box	Case	List
940-352	1/2	1.50	2.07	10	120	9.43
940-353	3/4	1.59	2.34	10	120	13.51
940-354	1	1.69	2.58	10	100	19.32
940-355	1-1/4	1.85	3.15	5	50	30.53
940-356	1-1/2	2.17	3.48	5	30	44.16
940-357	2	2.72	4.19	5	25	64.23
940-358	2-1/2	2.95	5.16	2	12	131.38
940-359	3	3.82	5.79	1	8	175.61
940-360	4	3.94	6.85	1	6	320.15

C X C



Part #	Size	Box	Case	List
940-362	1/2	10	100	11.32
940-363	3/4	10	120	13.51
940-364	1	10	100	23.18
940-365	1-1/4	5	50	36.64
940-366	1-1/2	5	30	44.16
940-367	2	5	25	64.23

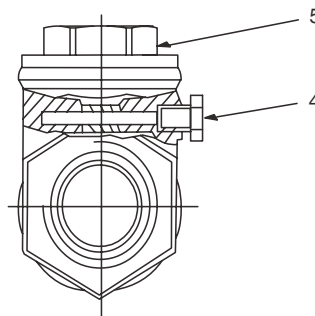
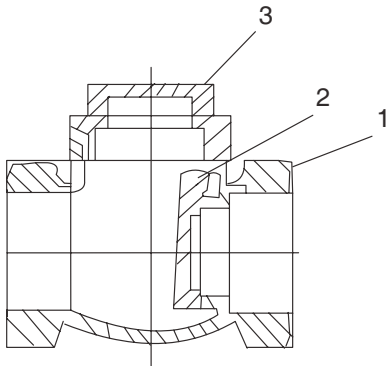

NO	Description	Material
1	Body	Cast Brass
2	Disc	Forged Brass
3	Pin	Brass
4	Plug Screw	Brass
5	Cap Cover	Cast Brass

