

COMPRESSION SLEEVES

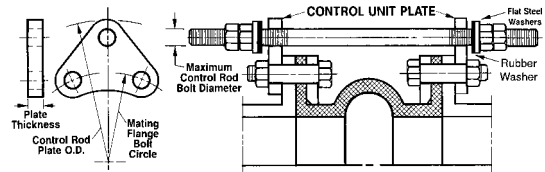

Table 5: Control Unit Plate Detail See Notes Below

NOMINAL SIZE Inch / (mm)	CONTROL ROD PLATE O.D. Inch / (mm)	MAXIMUM ² PLATE THK Inch / (mm)	MAXIMUM ³ ROD DIAMETER Inch / (mm)
1	(25)	8.375 (212.7)	0.625 (15.9)
1.25	(32)	8.750 (222.3)	0.625 (15.9)
1.5	(40)	9.125 (231.8)	0.625 (15.9)
2	(50)	10.125 (257.2)	0.625 (15.9)
2.5	(65)	11.125 (282.6)	1.000 (25.4)
3	(80)	11.625 (295.3)	1.000 (25.4)
3.5	(90)	12.625 (320.7)	1.000 (25.4)
4	(100)	13.125 (333.4)	1.000 (25.4)
5	(125)	14.125 (358.8)	1.000 (25.4)
6	(150)	15.125 (384.2)	1.000 (25.4)
8	(200)	19.125 (485.8)	1.000 (25.4)
10	(250)	21.625 (549.3)	1.000 (25.4)
12	(300)	24.625 (625.5)	1.000 (25.4)
14	(350)	26.625 (676.3)	1.000 (25.4)
16	(400)	30.125 (765.2)	1.250 (31.8)
18	(450)	31.625 (803.3)	1.250 (31.8)
20	(500)	34.125 (866.8)	1.250 (31.8)
22	(550)	36.125 (917.6)	1.250 (31.8)
24	(600)	38.625 (981.1)	1.250 (31.8)
26	(650)	40.875 (1038.2)	1.250 (31.8)
28	(700)	44.125 (1120.8)	1.500 (38.1)
30	(750)	46.375 (1177.9)	1.500 (38.1)
32	(800)	49.375 (1254.1)	1.500 (38.1)
34	(850)	52.375 (1330.3)	1.750 (44.5)
36	(900)	54.625 (1387.5)	1.750 (44.5)
38	(950)	57.375 (1457.3)	1.750 (44.5)
40	(1000)	58.375 (1482.7)	1.500 (38.1)
42	(1050)	61.625 (1565.3)	1.500 (38.1)
44	(1100)	63.875 (1622.4)	1.500 (38.1)
46	(1150)	65.875 (1673.2)	1.500 (38.1)
48	(1200)	68.125 (1730.4)	1.750 (44.5)
50	(1250)	70.375 (1787.5)	1.500 (38.1)
52	(1300)	73.625 (1870.1)	1.750 (44.5)
54	(1350)	75.875 (1927.2)	2.000 (50.8)
56	(1400)	78.375 (1990.7)	2.000 (50.8)
58	(1450)	80.625 (2047.9)	2.000 (50.8)
60	(1500)	82.625 (2098.7)	2.000 (50.8)
66	(1650)	89.625 (2276.5)	2.000 (50.8)
68	(1700)	91.875 (2333.6)	2.000 (50.8)
72	(1800)	96.125 (2441.6)	2.000 (50.8)
78	(2000)	103.125 (2619.4)	2.000 (50.8)
84	(2150)	109.875 (2790.8)	2.250 (57.2)
90	(2300)	117.125 (2975.0)	2.500 (63.5)
96	(2450)	124.625 (3165.9)	2.750 (69.9)
102	(2500)	131.375 (3336.5)	2.500 (63.5)
108	(2750)	138.125 (3508.4)	2.500 (63.5)
120	(3050)	152.125 (3864.0)	2.500 (63.5)
132	(3350)	166.625 (4232.2)	2.500 (63.5)
144	(3650)	180.750 (4591.1)	2.500 (63.5)

Also available with spherical washer

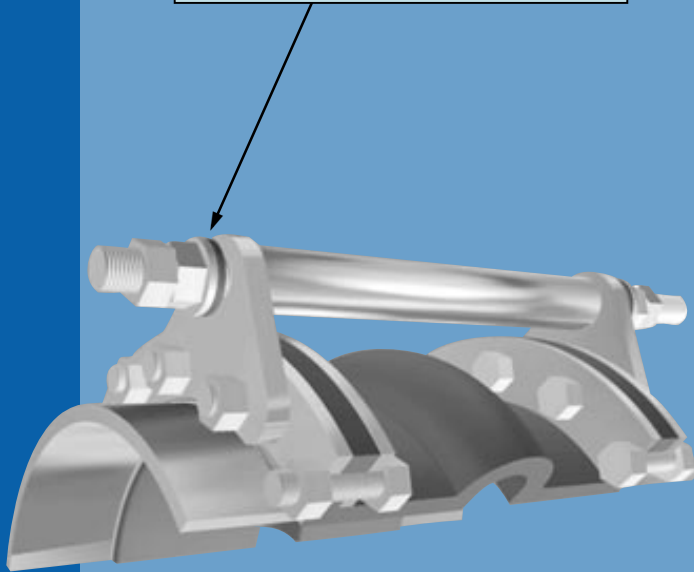
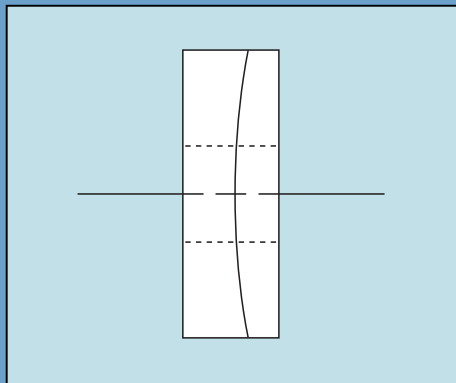

Figure 3: Compression Sleeves

Metric Conversion: Nominal I.D.: in. x 25 = mm; Dimensions: in. x 25.4 = mm; Pressure: PSIG x .069 = Bar
 Number of Control Units is dependent upon pressure and temperature of system. Refer to Fluid Sealing Association's - REJ Division Manual, Appendix C (Sixth Edition) for **minimum** number of control units (per pressure rating) required for a rubber expansion joint when specified.
 Values listed in this table are maximum values based on PROCO'S engineering data.