



Please call Goodyear Rubber Products to order any products shown in this catalog

1-727-822-4672 or 1-800-367-4673 toll free in the USA

Email inquiries to: Sales@GoodyearRubberProducts.com

Transair®, advanced air pipework systems

Product catalogue

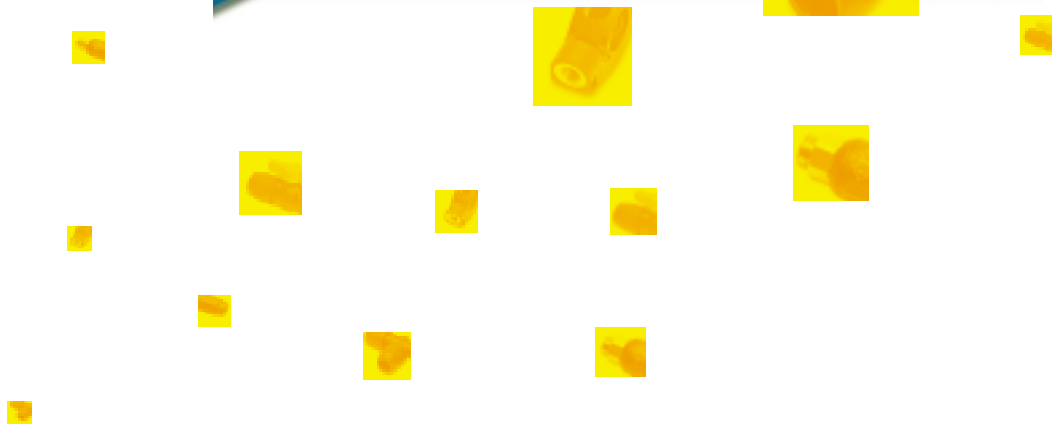

Transair®, advanced air pipework systems

Transair® is an innovative aluminium pipework system for the distribution of air, easy to assemble thanks to its rapid connection technology. With a wide product range and many accessories, Transair® helps you with your air network projects by offering a modern and energy efficient solution.

Transair® technology

The quick and easy assembly of Transair® is provided by its innovative technology : quick assembly connection to aluminium pipe (patented system).

• Quick connection with gripping ring

Ø 16,5 mm - 25 mm - 40 mm



• Quick connection with double clamp ring

Ø 63 mm

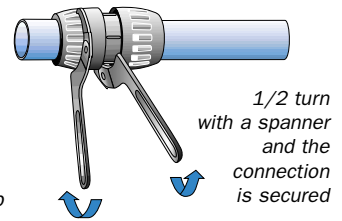
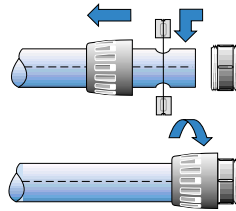
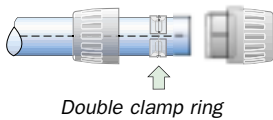

Technical specifications

Suitable fluids :

- Compressed air (dry, wet, lubricated)
- Vacuum
- Inert gas : argon, nitrogen (other fluids, please consult us)

Max working pressure :

- 16 bar - please consult us for temperature range
- 13 bar from -20°C to +60°C

Vacuum level :

- 98,7% (13 mbar absolute pressure)

Working temperature :

- From -20°C to +60°C

Excellent resistance to :

- Compressor oils (mineral or synthetic)
- Ultra-violet rays (For other fluids please consult us)

Storage temperature :

- From -40°C to +80°C

Transair® components are non-flammable, with no propagation of flame. Materials 100 % recyclable. For silicone free applications : please contact us.

Identification

Part numbers have been chosen by a method of mnemonics. Each Transair® component is identified by :

- Its series
- Pipe OD
- Thread code or second pipe OD

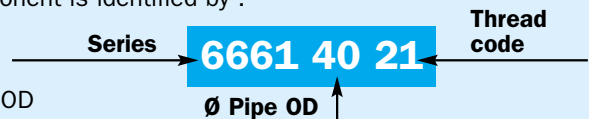

Certification

Our manufacturing process includes individual control and unit dating for all Transair® fittings and pipe, in order to guarantee their quality and traceability.

Regarding security, Transair® conforms to European standard 97/23 CEE - § 3.3 (equipment under pressure).



Transair® meets the requirements of ASME B31.1



		4-5	Pipe-to-pipe and stud connectors
		6	Rigid aluminium pipe & Flexible hose
		7	Quick assembly brackets
		8	Ball valves
		9	Wall brackets
		10-11	Tools
		11	Pressurised system outlets
		12-13	Fixture accessories
		14-15	Air distribution columns
		16-19	Composite automatic safety couplers
		20-22	Metal automatic safety couplers
		23	Hose reels & Blowgun
		24-26	Connection accessories
		27	Tubes & Hoses
		28	FRLs, Automatic drain & Accessories
		29	Installation guide
		30	Index
		31	Transair® worldwide

Legris has a policy of continual product development and, therefore, reserves the right to modify any products shown in this catalogue, without notification. All dimensions are indicative.

Pipe-to-pipe and stud connectors

- Quick connection
- Full bore design
- Interchangeable and reusable
- Non-flammable materials (UL94-HB standard)

- Max working pressure :
 - 16 bar – please consult us for temperature range
 - 13 bar from -20°C to +60°C
- Vacuum level : 98,7% (13mbar absolute pressure)
- Working temperature : -20°C to +60°C

The range of **Transair®** pipe-to-pipe and stud connectors provides versatility of design and helps to overcome constraints often encountered with the structure of industrial buildings

6605 Male stud fitting, BSP taper

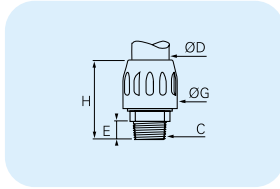

ØD	C	Transair®	E	G	H	Δ kg Δ
16,5	R1/4	6605 17 13	9,5	34,0	62,5	0,101
16,5	R1/2	6605 17 21	15,0	34,0	68,0	0,111
25	R1/2	6605 25 21	15,0	44,5	70,5	0,165
25	R3/4	6605 25 27	15,0	44,5	71,5	0,178
25	R1"	6605 25 34	16,0	44,5	71,5	0,230
40	R1"	6605 40 34	16,0	67,0	111,5	0,585
40	R1"1/4	6605 40 42	21,5	67,0	111,5	0,540
40	R1"1/2	6605 40 49	24,5	67,0	114,5	0,625
63	R2"	6605 63 48	20,0	91,0	118,5	1,090
63	R2"1/2	6605 63 47	25,0	91,0	130,5	1,480

6602 Equal elbow

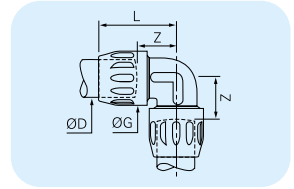

ØD	Transair®	G	L	Z	Δ kg Δ
16,5	6602 17 00	34,0	58,0	31,0	0,069
25	6602 25 00	44,5	68,0	40,0	0,129
40	6602 40 00	67,0	107,0	45,0	0,415
63	6602 63 00	91,0	122,0	61,0	0,980

6606 Equal pipe-to-pipe connector

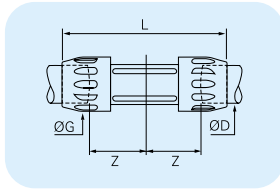

ØD	Transair®	G	L	Z	Δ kg Δ
16,5	6606 17 00	34,0	120,5	33,5	0,071
25	6606 25 00	44,5	151,5	48,0	0,129
40	6606 40 00	67,0	205,0	57,0	0,400
63	6606 63 00	91,0	171,5	25,0	0,860

6612 45° elbow

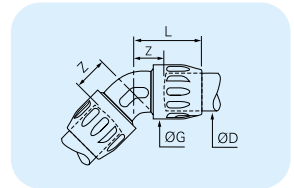

ØD	Transair®	G	L	Z	Δ kg Δ
25	6612 25 00	44,5	57,0	29,0	0,115
40	6612 40 00	67,0	90,0	45,0	0,370

6676 Equal pipe-to-pipe connector with vent

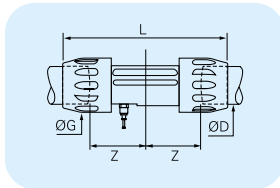

ØD	Transair®	G	L	Z	Δ kg Δ
25	6676 25 00	44,5	151,5	48,0	0,150
40	6676 40 00	67,0	205,0	57,0	0,420
63	6676 63 00	91,0	171,5	49,0	0,855

Model supplied with 1/4" fitting and Ø8 mm plug-in cap

6604 Equal tee

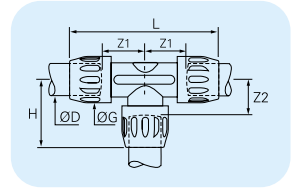

ØD	Transair®	G	H	L	Z1	Z2	Δ kg Δ
16,5	6604 17 00	34,0	58,0	120,5	33,5	31,0	0,100
25	6604 25 00	44,5	67,5	151,5	48,0	40,0	0,190
40	6604 40 00	67,0	102,5	205,0	57,0	57,0	0,595
63	6604 63 00	91,0	122,0	245,0	61,0	61,0	1,410

Materials

6605	Ø 16,5 - 25 - 40	Ø 63
• Body	Plated-brass	Treated brass
• Nuts	Engineering grade plastic	Treated aluminium

6606/6676/6602/6612/6604	Ø 16,5 - 25 - 40	Ø 63
• Body	Engineering grade plastic	Treated aluminium
• Nuts	Engineering grade plastic	Treated aluminium

6604 Reducing tee

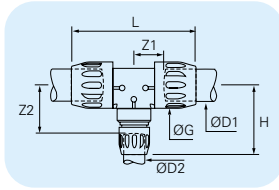

ØD1	ØD2	Transair®	G	H	L	Z1	Z2	Δkg
63	40	6604 63 40	91,0	161,0	245,0	61,0	116,0	2,050

6666 Screw-on reducer

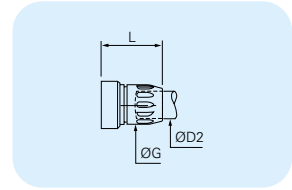

ØD1	ØD2	Transair®	G	L	Δkg
63	40	6666 40 63	67,0	112,5	0,940

The 63 mm to 40 mm reducer is secured by a 63 mm screw-on nut.

6607 Equal cross

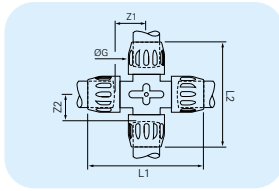

ØD	Transair®	G	L1	L2	Z1	Z2	Δkg
25	6607 25 00	44,5	152,0	135,0	48,0	40,0	0,240

6625 Vented end-cap

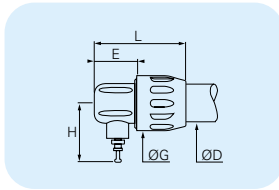

ØD	Transair®	E	G	H	L	Δkg
16,5	6625 17 00	25,5	34,0	45,5	62,5	0,145
25	6625 25 00	33,0	44,5	47,0	75,0	0,164
40	6625 40 00	34,5	67,0	55,0	98,5	0,189
63	6625 63 00	31,0	91,0	74,0	105,0	0,480

Model Ø16,5 mm : supplied with Ø6 mm plug

Models Ø25, Ø40 and Ø63 mm : supplied with Ø8 mm plug.

6621 Male adaptor, BSP taper

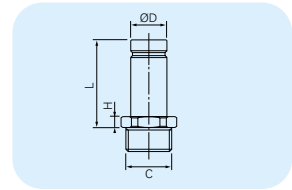

ØD	C	Transair®	L	H	Δkg
16,5	R1/2	6621 17 21	42,2	5,0	0,020
25	R1/2	6621 25 21	49,0	7,0	0,035
25	R3/4	6621 25 27	49,0	7,0	0,057
40	R1"1/4	6621 40 42	73,7	8,0	0,139
40	R1"1/2	6621 40 49	75,7	10,0	0,172

6666 Plug-in reducer

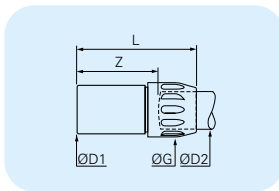

ØD1	ØD2	Transair®	G	Z	L	Δkg
25	16,5	6666 17 25	34,0	50,0	77,0	0,050
40	25	6666 25 40	44,5	71,5	99,0	0,116

6651 Manifold

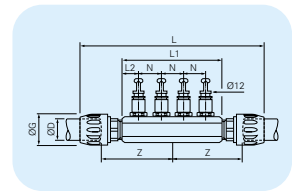

ØD	Transair®	G	L	L1	L2	N	Z	Δkg
25	6651 25 12 04	44,5	271,0	151,0	23,0	35,0	108,0	1,060
40	6651 40 12 04	67,0	400,0	204,0	27,0	50,0	152,0	2,800

Supplied with 4 Ø12 mm plugs (3126 12 00)

Materials

6604/6607/6625	Ø 16,5 - 25 - 40	Ø 63
• Bodies	Engineering grade plastic	Treated aluminium
• Nuts	Engineering grade plastic	Treated aluminium

6666/6651	Ø 16,5 - 25 - 40	Ø 63	6621 :
• Bodies	Plated brass	Treated aluminium	Treated aluminium
• Nuts	Engineering grade plastic	Treated aluminium	aluminium

Rigid aluminium pipe & Flexible hose

Rigid aluminium calibrated pipe

- Clean air
- Optimum flow rate performance
- Low weight
- Suitable fluids : compressed air, vacuum, nitrogen, argon (other fluids, please consult us)
- Max working pressure :
 - 16 bar – please consult us for temperature range
 - 13 bar from -20°C to +60°C
- Vacuum : 98,7% (13 mbar absolute pressure)
- Working temperature : -20°C to +60°C
- Extruded pipe (conforms to EN 755.2, EN 755.8 and EN 573.3 standards)

Flexible hose

- Compressor outlets (absorption of vibration)
- To bypass obstacles and join different levels
- Expansion loops
- Max working pressure :
 - 16 bar – please consult us for temperature range
 - 13 bar from -20°C to +60°C
- Vacuum : 98,7% (13 mbar absolute pressure)
- Working temperature : -20°C to +70°C
- Resistant to mineral and synthetic compressor oils
- Fire resistant (conforms to ISO 8030 standard for compressed air flexible hose and EN 12115 for vacuum flexible hose)

1003A 3m rigid aluminium pipe

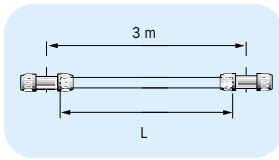
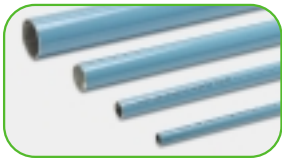

Øext.	Øint.	Transair®	L (m)	Δ kg Δ
16,5	13	1003A17 04 00	2,930	0,750
25	22	1003A25 04 00	2,903	1,100
40	37	1003A40 04 00	2,885	1,900
63	59	1003A63 04	2,950	3,200

1006A 6 m rigid aluminium pipe

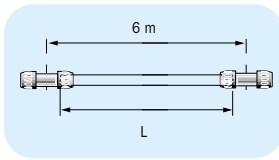
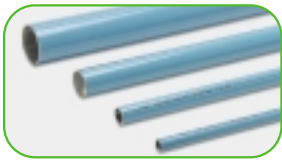

Øext.	Øint.	Transair®	L (m)	Δ kg Δ
25	22	1006A25 04 00	5,903	2,200
40	37	1006A40 04 00	5,885	4,000
63	59	1006A63 04	5,950	6,400

0000 Sticker for vacuum networks



Transair®

0000 01 68

1001E Flexible hose for compressed air networks



6698

Anti whip-lash strap ⁽¹⁾



6698 99 03

Øext.	Øint.	Transair®	L	Min bend radius (mm)	For use with Transair® pipe diameter	Δ kg Δ
38	25	1001E25 00 01	0,570	75	25	0,544
38	25	1001E25 00 03	1,500	75	25	1,488
38	25	1001E25 00 04	2,000	75	25	1,997
54	40	1001E40 00 02	1,150	160	40	2,075
54	40	1001E40 00 04	2,000	160	40	3,319
54	40	1001E40 00 05	3,000	160	40	4,000
79,5	63	1001E63 00 08	1,400	300	63	3,920
79	63	1001E63 00 05	3,000	250	63	8,060
79	63	1001E63 00 06	4,000	250	63	10,700

(1) Prevents whip-lash should Transair® flexible hose become disconnected whilst under pressure.

Conforms to the ISO 4414 safety standard.

1001E Flexible hose for vacuum networks



6698

Anti whip-lash strap ⁽¹⁾



6698 99 03

Øext.	Øint.	Transair®	L	Min bend radius (mm)	For use with Transair® pipe diameter	Δ kg Δ
36	25	1001E25V00 01	0,570	75	25	0,900
36	25	1001E25V00 03	1,500	75	25	2,500
36	25	1001E25V00 04	2,000	75	25	3,000
52	40	1001E40V00 07	0,950	160	40	1,750
52	40	1001E40V00 04	2,000	160	40	4,000
52	40	1001E40V00 05	3,000	160	40	4,500
79,5	63	1001E63 00 08	1,400	300	63	3,920
76	63	1001E63V00 05	3,000	250	63	8,740
76	63	1001E63V00 06	4,000	250	63	10,890

Materials

- Rigid aluminium pipe :
 - Paint Qualicoat certified
- Anti whip-lash strap
 - steel



- Flexible hose for air compressed networks :
 - Hose and coating : black SBR
 - Reinforcement : synthetic braiding
- Flexible hose for vacuum networks :
 - Hose and coating : black SBR/NBR
 - Reinforcement : spiral steel wire

Quick assembly brackets

- Quick assembly without cutting the pipe
- Horizontal or vertical connection
- Integral condensate retention device
- Non-flammable (conforms to UL94-HB standard)



- Max working pressure :
 - 16 bar – please consult us for temperature range
 - 13 bar from -20°C to +60°C
- Vacuum : 98,7% (13 mbar absolute pressure)
- Working temperature : -20°C to +60°C

In order to add a new outlet without shutting off the air supply, please use the "Pressurised System Connection Tool" (page 11).

Reduced overall dimension.
Protection of downstream network.

6662 Quick assembly bracket

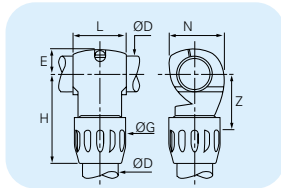

ØD	Transair®	E	G	H	L	N	Z	ΔkgΔ
25	6662 25 00	31,0	44,5	79,5	36,0	47,5	52,0	0,115
40	6662 40 00	37,0	67,0	119,5	72,0	74,5	74,0	0,365

6661 Quick assembly mini-bracket with female thread

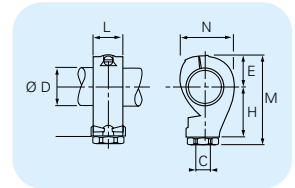

ØD	C	Transair®	E	H	L	N	M	ΔkgΔ
25	G1/2	6661 25 21	30,8	51,3	36,0	46,5	90,1	0,116
40	G1/2	6661 40 21	39,2	66,0	37,2	58,2	113,4	0,156
63	G1/2	6661 63 21	63,5	75,4	50,0	98,5	148,0	0,320
63	G3/4	6661 63 27	63,5	75,4	50,0	98,5	148,0	0,460

6662 Quick assembly reducing bracket

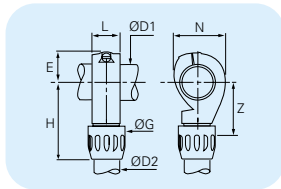

ØD1	ØD2	Transair®	E	G	H	L	N	Z	ΔkgΔ
25	16,5	6662 25 17	30,8	34,0	84,0	36,0	47,5	57,0	0,099
40	16,5	6662 40 17	39,0	34,0	99,8	37,2	67,5	73,0	0,138
40	25	6662 40 25	39,0	44,5	95,0	37,2	67,5	68,0	0,154
63	25	6662 63 25	63,5	44,5	103,0	50,0	108,5	75,0	0,330

6660 Mini-bracket with coupler



ØD	C	Transair®	Profile	Bore (mm)
25	G1/2	6660 25 U1	ISO B	5,5
25	G1/2	6660 25 U2	ISO B	8
25	G1/2	6660 25 E4	EURO	7,2
25	G1/2	6660 25 A1	ARO	5,5
40	G1/2	6660 40 U1	ISO B	5,5
40	G1/2	6660 40 U2	ISO B	8
40	G1/2	6660 40 E4	EURO	7,2
40	G1/2	6660 40 A1	ARO	5,5
63	G1/2	6660 63 U1	ISO B	5,5
63	G1/2	6660 63 U2	ISO B	8
63	G1/2	6660 63 E4	EURO	7,2
63	G1/2	6660 63 A1	ARO	5,5

Materials

6662/6661*/6660	Ø 16,5 - 25 - 40	Ø 63
• Body	Engineering grade plastic*	Engineering grade plastic
• Nut	Engineering grade plastic	Engineering grade plastic

Coupler : composite material
(see details p16-19)

*Brass insert

Ball valves

- Quick connection
- Available in lockable version
- Manual or piloted operation
- Non-flammable
(conforms to UL94-HB standard)

- Working pressure :
 - 16 bar – please consult us for temperature range
 - 13 bar from -20°C to +60°C
- Vacuum level : 98,7% (13 mbar absolute pressure)
- Working temperature : -20°C to +60°C

Transair® ball valves placed regularly throughout the network and at key locations, such as compressor outlets and upstream of pneumatic tools, allow ease of system isolation, adaptation and maintenance.

4002 Double female

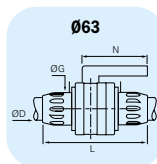
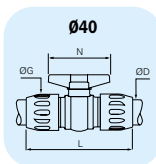

ØD	Transair®	G	L	N	Δ kg Δ
40	4002 40 00	67,0	205,0	122,0	0,600
63	4002 63 00	67,0	278,0	185,0	2,425

4230 Remote control shut-off valve

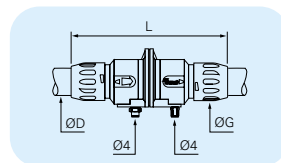

ØD	Transair®	E	G	Δ kg Δ
40	4230 00 40	67	261	1,805

Min working pressure : 4 bar • **Max working pressure :** 13 bar
The **Transair®** remote control shut-off valve is supplied with a plugged vent hole. This allows venting of the downstream network, after closing the valve.

4089 Double female, vented

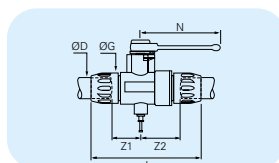

ØD	Transair®	G	L	N	Z1	Z2	Δ kg Δ
16,5	4089 17 00	34,0	120,0	69,5	27,0	40,0	0,340
25	4089 25 00	44,5	152,0	108,5	41,0	59,0	1,090

Model 4089 17 00 : supplied with Ø6 mm plug
Model 4089 25 00 : supplied with Ø8 mm plug

4299 Pilot kit

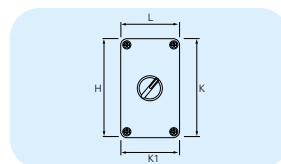

Transair®	H	K	K1	L	Δ kg Δ
4299 03 01	145	106	70	82	0,795

This pilot kit comprises : pneumatic ON/OFF switch, maximum 10 bar operating pressure, twin 4mm OD polyurethane tube, length 10m, plastic box.

4012 Lockable valve

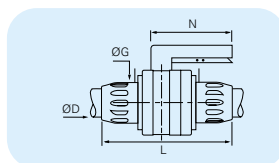

ØD	Transair®	G	L	N	Δ kg Δ
63	4012 63 00	67	278,0	185,0	2,425

4934 Ball valve, male and female, BSP taper

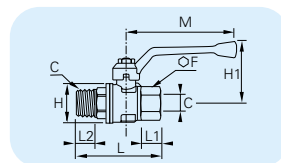

C	ØN	Transair®	F	H	H1	L	L1	L2	M	Δ kg Δ
R3/4	20	4934 20 27TR	31	39	60	16	18,5	110	0,36	0,385
R1"	25	4934 25 34 TR	38	49	64	19	21,5	110	0,57	0,591
R1 1/4	32	4934 32 42TR	48	59	78	21	24	160	0,94	1,069
R1 1/2	40	4934 40 49TR	54	73	86	21	24	160	1,5	1,515

Max working pressure. : 25 bar

4981 Mini valve, male and female, BSP taper

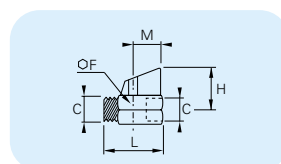

C	ØN	Transair®	F	H	L	M	Δ kg Δ
R1/2	10	4981 10 21TR	25	31	46	20,5	0,137

Max Working pressure : 10 bar

Materials

4002/4012 Ø 40	Ø63	
• Body	Engineering grade plastic	Engineering grade plastic
• Nut	Engineering grade plastic	Plated aluminium

4089/4099/4230 Ø 16,5 - 25 - 40	
• Body	Plated brass
• Nut	Engineering grade plastic

4934/4981	
• Body	Plated brass
• Seal	PTFE and nitrile

Wall brackets

- 1 port or 2 ports
- Pre-assembled composite safety coupler (6670)
- Mounting on walls or machinery
- Non-flammable (conforms to UL94-HB standard)

- Working pressure :
 - 16 bar – please consult us for temperature range
 - 13 bar from -20°C to +60°C
- Vacuum level : 98 ,7% (13 mbar absolute pressure)
- Working temperature : -20°C to +60°C

6680 1 port wall bracket, BSP parallel

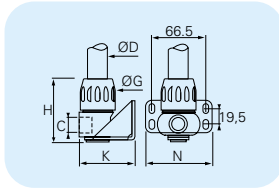

ØD	C	Transair®	G	H	K	N	kg
16,5	G1/2	6680 17 21	34	65	70,5	82	0,462
25	G1/2	6680 25 21	44,5	81	70,5	82	0,494

6681 2 port wall bracket, BSP parallel

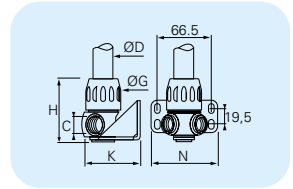

ØD	C	Transair®	G	H	K	N	kg
16,5	G1/2	6681 17 21	34	65	74,5	82	0,411
25	G1/2	6681 25 21	44,5	81	74,5	82	0,450

6685 1 port threaded wall bracket, BSP parallel

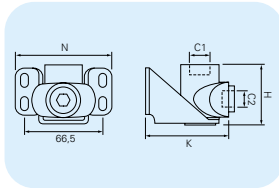

C1	C2	Transair®	H	K	N	kg
G1/2	G1/2	6685 21 21	48	72,5	82	0,475

6686 2 port threaded wall bracket, BSP parallel

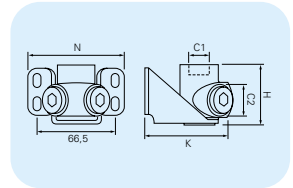

C1	C2	Transair®	H	K	N	kg
G1/2	G1/2	6686 21 21	48	66,5	82	0,420

6670 1 port wall bracket, with coupler



ØD	Transair®	Profile	Bore (mm)
16,5	6670 17 U1	ISO B	5,5
16,5	6670 17 U2	ISO B	8,0
16,5	6670 17 E4	EURO	7,2
16,5	6670 17 A1	ARO	5,5
25	6670 25 U1	ISO B	5,5
25	6670 25 U2	ISO B	8,0
25	6670 25 E4	EURO	7,2
25	6670 25 A1	ARO	5,5

1/2" BSP parallel connection between the wall bracket and the composite safety coupler.

6671 2 port wall bracket, with coupler



ØD	Transair®	Profile	Bore (mm)
16,5	6671 17 U1	ISO B	5,5
16,5	6671 17 U2	ISO B	8,0
16,5	6671 17 E4	EURO	7,2
16,5	6671 17 A1	ARO	5,5
25	6671 25 U1	ISO B	5,5
25	6671 25 U2	ISO B	8,0
25	6671 25 E4	EURO	7,2
25	6671 25 A1	ARO	5,5

1/2" BSP parallel connection between the wall bracket and composite safety coupler. Couplers supplied with the wall bracket are ready for immediate use.

Materials

6670/6671/6680/6681/6685/6686	Ø 16,5 - 25
• Body	Plated brass
• Nut	Engineering grade plastic

Coupler : composite material (see details p16-19)

Tools

- Practical tools for the installation and extension of **Transair®** air pipe networks
- Presented in a carrying case, or available as separate parts

6698 Cutter for rigid aluminium pipe

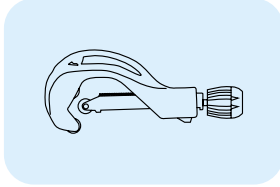

Transair®



6698 03 01

0,760

For Ø 16.5, 25, 40 and 63 mm.

6698 Drilling tool for rigid aluminium pipe

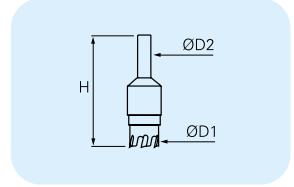

ØD1 ØD2 **Transair®**

For pipe
Transair®

H



16

12

6698 02 02

25

71

0,147

22

12

6698 02 01

40 - 63

71

0,148

May be used with all types of drills. • **Rotation speed** : 650 rpm maximum.

6698 Drilling jig for rigid aluminium pipe Ø 25 mm and Ø 40 mm

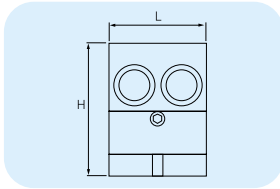

Transair®

H

L



6698 01 01

120

80

0,860

After drilling, deburr and clean the pipe.

6698 Deburring tool for rigid aluminium pipe

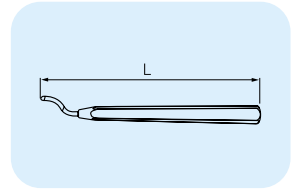

Transair®

L



6698 04 02

140

0,020

6698 Drilling jig for rigid aluminium pipe Ø 63 mm

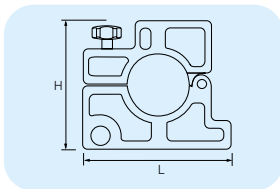

Transair®

H

L



6698 01 02

134

155

2,245

After drilling, deburr and clean the pipe.

6698 Chamfer tool for rigid aluminium pipe

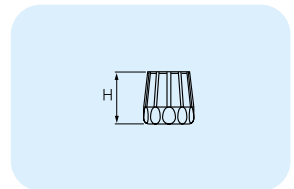

Transair®

H



6698 04 01

64

0,113

For Ø 16.5, 25 and 40 mm.

6698 Set of tightening spanners for 63 mm nuts



Transair®



6698 05 03

0,734

This set includes 2 tightening spanners.

6698 Tool case



Transair®

H

L



6698 00 03

315

290

5,900

This tool case simplifies the use and transportation of tools. It contains all the tools necessary for completing a Transair® installation :

- Drilling jigs 6698 01 01 and 6698 01 02
- Drilling tools 6698 02 01 and 6698 02 02
- Cutter for rigid pipe 6698 03 01
- Chamfer tool 6698 04 01
- Deburring tool 6698 04 02
- Set of tightening spanners 6698 05 03
- Marking tool 6698 04 03

6698 Marking tool for aluminium pipe

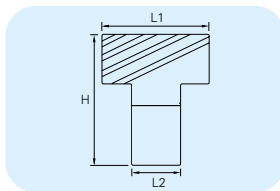

Transair®

H

L1

L2



6698 04 03

88

73

33

0,040

The marking tool enables connection guidelines to be marked on cut lengths of Transair® pipe. These marks indicate the insertion limits of the pipe into the fitting in order to ensure good airtight connection and security of grip.

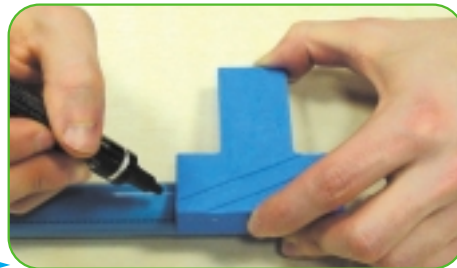

Pressurised system outlets

- Ideal for fast assembly of new pressurised outlets, without venting the compressed air network.
- The drilling tool can be used with most standard drills

We recommend however that the pipework network is drained prior to assembly of an outlet. Thanks to lateral dismantling of Transair® pipe and the “easily assembled” outlet brackets (see pages 6 and 7), this operation can be done very quickly (less than 7 min. for a new outlet) and guarantees the interior cleanliness of the circuit.

EA98 Pressurised system drilling tool

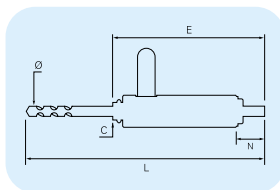

C Ø Transair®

L

E

N



G1/2

13

EA98 06 00

330,0

154,0

30,5

0,545

EA98 Pressurised system bracket



ØD

Transair®

25

EA98 06 01

40

EA98 06 02

63

EA98 06 03

Ball valve with bracket
(1/2" BSP parallel thread)

Materials

Pressurised system drilling tool :

- Body - aluminium
- Drill - steel
- Adaptor and Cap - brass
- Silencer - plastic

Fixture accessories

- Can be adapted to all pipework configurations
- For suspension of pipes, from walls, partitions, beams, cable trays, Canalis electrical installations, etc..., vertically and horizontally
- Perfectly suited for use with **Transair®** networks

6697 Fixing clip for rigid pipe

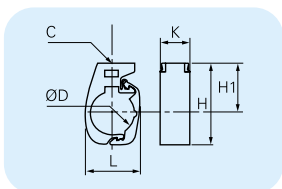

ØD	C	Transair®	H1	H	K	L
16,5	M6X1	6697 17 00	46	61	30	32,5
25	M6X1	6697 25 00	46	65,5	30	38,5
40	M6X1	6697 40 00	46	74,5	30	50
63	M10X1,5	6697 63 00	90	127,5	30	73,5

Transair® fixing clips are designed to bear a maximum weight of 20 kg. However, to ensure good stability of the network, we recommend the use of at least 2 clips per pipe i.e.:

- maximum 1,5 m space between clips for 3 m lengths of pipe.
 - maximum 3 m space between clips for 6 m lengths of pipe.
- Use only this clip for fixing **Transair®** rigid pipe, all other type of pipe clips are to be avoided. Fix the clip to a rigid support (U-channel, cable tray) to allow for expansion whilst retaining the pipe.

6697 Spacer

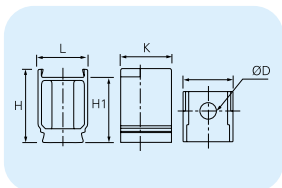

ØD	Transair®	H	H1	K	L	Δ kg Δ
11	6697 00 03	49,5	44	34	33	0,020

This spacer, in association with the **Transair®** clip, allows consistent alignment of pipes.

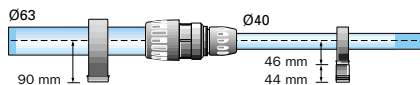

6697 Clip adaptor for threaded rod

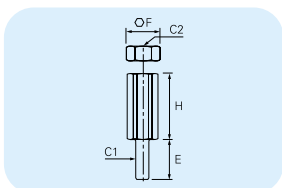

C1	C2	Transair®	E	F	H	Δ kg Δ
M6x1	M8x1,25	6697 00 01	16	13	30	0,035
M6x1	M10x1,5	6697 00 02	16	13	30	0,054

The use of this adaptor facilitates the suspension of **Transair®** under M8 or M10 threaded rod.

6699 U-channel, 2 metres

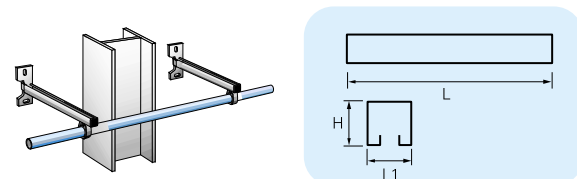

Transair®	H	L (m)	L1	Δ kg Δ
6699 01 01	25	2	25	1,500

For RSJ fixing clips please see 6699 03 02 on Page 13

6699 U-channel fixing bracket

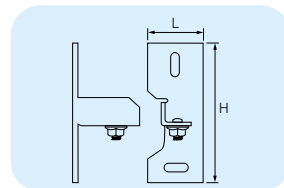
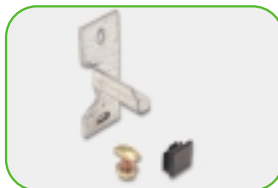

Transair®	H	L	Δ kg Δ
6699 01 02	106	40	0,170

The set comprises :

- 1 bracket
- 1 screw
- 1 nut
- 1 end cap

6699 U-channel clip fixing set Ø 63 mm

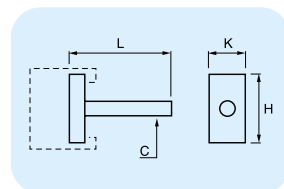

C	Transair®	H	K	L	Δ kg Δ
M10	6699 01 03	35	20	50	0,095

The set comprises :

- 1 channel nut + M10 threaded rod
- 1 washer
- 1 nut

Materials

- **Fixing clips** : polymer H.R.
- **Spacer** : polymer H.R.
- **Clip adaptor** : brass
- **U-channel** : galvanised steel
- **Set of fixing accessories** : galvanised steel
- **Clip fixing set Ø 63 mm** : galvanised steel

6699 Push-on type beam clamp

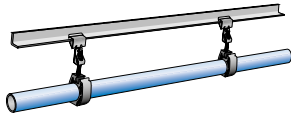
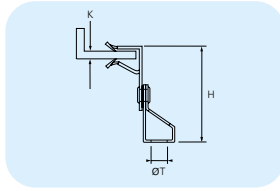

Transair®	H	K	ØT	Max carrying load (kg)
6699 02 01	44	1,5 to 3	M6	68
6699 02 02	46	3 to 8	M6	68
6699 02 03	54	8 to 14	M6	68
6699 02 04	66	14 to 20	M6	68
6699 02 05	44	1,5 to 3	M10	68
6699 02 06	46	3 to 8	M10	68

6699 Screw type beam clamp

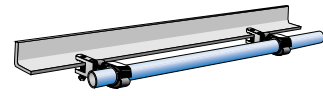
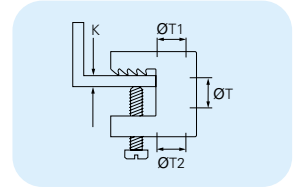

Transair®	ØT2	ØT	ØT1	K	Max carrying load (kg)
6699 03 01	10,7	6,5	10,7	18	45

6699 Fixture on KN CANALIS

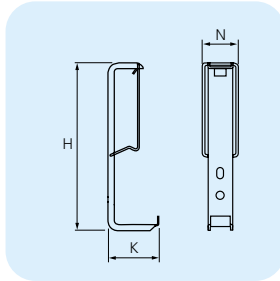

Transair®	H	K	N	Δ kg Δ
6699 10 01	200	60	37	0,110

6699 Fixture on KS CANALIS

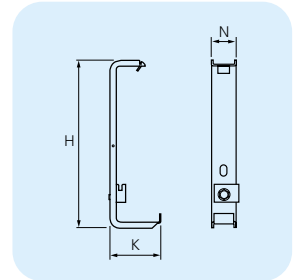

Transair®	H	K	N	Δ kg Δ
6699 10 02	200	60	30	0,120

6699 U-channel fixture bracket for RSJ

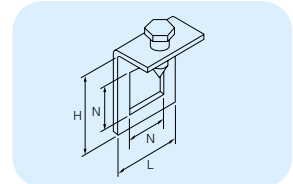
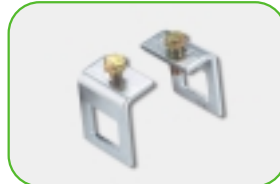

Transair®	H	L	N	Δ kg Δ
6699 03 02	49	41	25	0,080

Supplied with one 8 x 25 needle screw

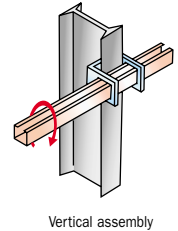
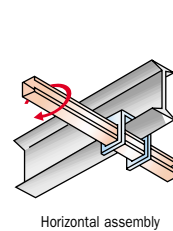
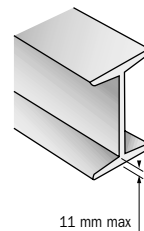

6699 Fixture on cable tray

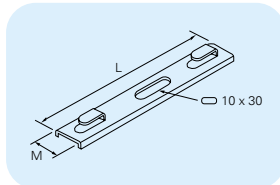

Transair®	L	M	Δ kg Δ
6699 10 03	140	22	0,035

Ø tray rod : 4 to 6 mm

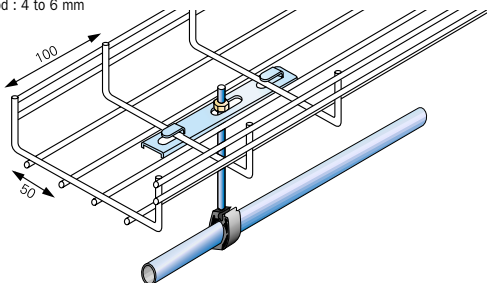

Materials

- Fixture on KN and KS Canalis : Bichromated steel zinc-coated
- Push-on type beam clamp and screw type beam clamp : galvanised steel
- Fixture on cable tray : galvanised steel
- Fixture on RSJ : galvanised steel and brass screw

Air distribution columns

- Provide an enclosed energy supply to work stations and production areas
- Can be used vertically or horizontally
- Suitable for enclosure of electrical cabling

- Fluids : compressed air, vacuum, argon, nitrogen (for other fluids, please consult us)
- Maximum working pressure : 13 bar
- Vacuum level : 98,7% (13 mbar absolute pressure)
- Working temperature : -20°C to +60°C

Protection and rationalisation of drops.

6699 Column with floor/wall fixing

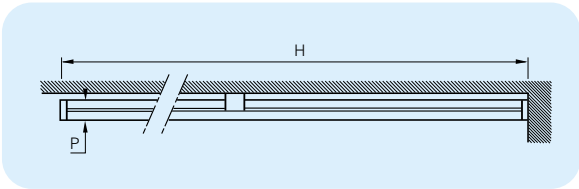

Transair®	H	P	Δ kg Δ
6699 04 01	2500	60	6,000

6699 Column with floor/ceiling fixing

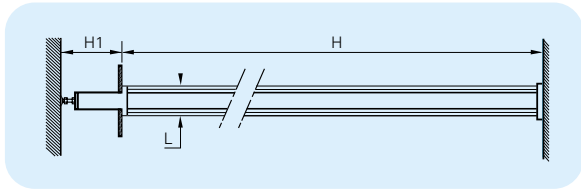

Transair®	H	H1 (maxi)	L	Δ kg Δ
6699 04 02	2450	600	100	7,000

With telescopic cylinder

6699 Module with one threaded outlet

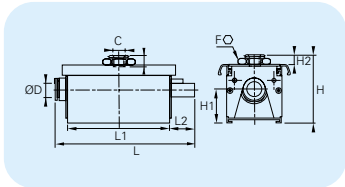

ØD	C	Transair®	F	H	H1	H2	L	L1	L2	Δ kg Δ
14	G1/4	6699 04 60	24	62	29,5	8,5	136,5	109,5	20	0,429
14	G1/2	6699 04 60 01	24	75,5	33	18,5	137	103	23	0,470

6699 Module with ball valve

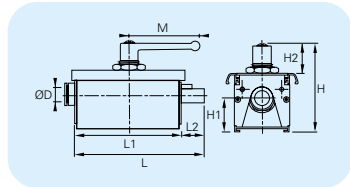

ØD	Transair®	H	H1	H2	L	L1	L2	M	Δ kg Δ
14	6699 04 63	82,5	29,5	29	136,5	109,5	20	69,5	0,552



Materials

- Column : anodised aluminium
- Module : aluminium

6699 Module with pressure gauge

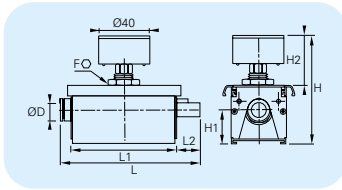

ØD	Transair®	F	H	H1	H2	L	L1	L2	Δkg
14	6699 04 64	24	28	29,5	44,5	136,5	109,5	20	0,510

6699 Pilot valve module

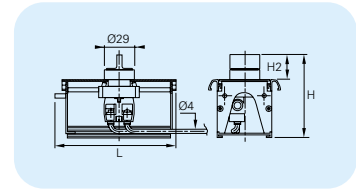

Transair®	H	H2	L	Δkg
6699 04 65	82	25	124,5	0,424

The pilot valve module includes :
 - pneumatic ON/OFF switch, maximum operating pressure 10 bar
 - twin polyurethane tube, 10m length, 4mm OD

3126 Plug

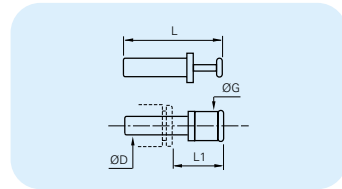

ØD	Transair®	G	L	L1	Δkg
14	3126 14 00TR	16	49	23,5	0,005

To plug the end of a module.

3114 Female stud fitting, BSP parallel

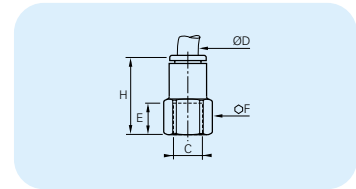

ØD	C	Transair®	E	F	H	Δkg
14	G3/8	3114 14 17TR	14	22	42,5	0,120

To connect modules to braided PVC hose, using hositail adaptor EF26 – see Page 26.

Installation

In order to meet users requirements, **Transair®** air distribution columns can be installed on the work-bench or within the production area.

Columns

Wall and floor fixing or floor and ceiling fixing

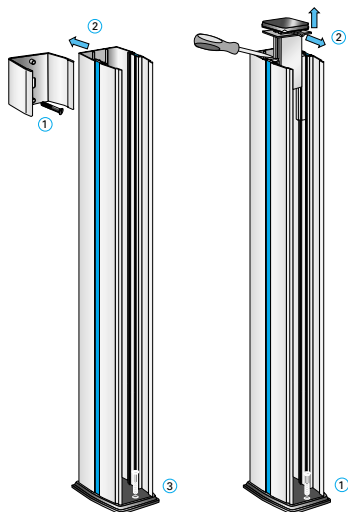

- 1- Fix the mounting bracket on the wall
- 2- Fix the column
- 3- Screw sub-base to the floor

- 1- Fix the sub-base to the floor
- 2- Release the cylinder to lock the column.

Modules



- 1- Measure and cut at the required height
- 2- Connect the modules together
- 3- Fix into the column

Composite automatic safety couplers – ISO B profile - 5,5 mm

- For quick and repetitive connection and disconnection
- 100% safety - **ISO 4414 and EN983 compliant**
- Very high flow, extremely small pressure loss
- Lightweight and robust
- Improved hand grip
- Fast vent time

- Suitable fluids : compressed air , argon, nitrogen (please consult us for other fluids)
- Working pressure : 16 bar maximum
- Working temperature : from -20°C to +60°C

Flow : 1250 NI/min (44 cfm)

Safety

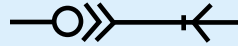

ISO 6150 B
AFNOR NF 49-053
US.MIL.C4109
CEJN 310
RECTUS 23-24

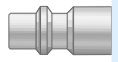

CP01 Male body, BSP parallel



C Transair®

G1/4	CP01 U1 02
G3/8	CP01 U1 03
G1/2	CP01 U1 04

Complete with sealing ring

CA87 Male probe , BSP parallel



C Transair®

G1/4	CA87 U1 02
G3/8	CA87 U1 03
G1/2	CA87 U1 04

Complete with sealing ring

CP14 Female body, BSP parallel



C Transair®

G1/4	CP14 U1 02
G3/8	CP14 U1 03
G1/2	CP14 U1 04

CA86 Female probe, BSP parallel



C Transair®

G1/4	CA86 U1 02
G3/8	CA86 U1 03
G1/2	CA86 U1 04

CP21 Body with hosetail



ØD Transair®

6	CP21 U1 06
8	CP21 U1 08
10	CP21 U1 10

Suitable for use with Transair® PVC hose (see p. 27)

CA94 Probe with hosetail



ØD Transair®

6	CA94 U1 06
8	CA94 U1 08
10	CA94 U1 10

Suitable for use with Transair® PVC hose (see p. 27)

CA90 Probe adaptor



CA90 U1 01



CA90 U1 03

Transair®

Profile

Profile

CA90 U1 01	ISO C6	to	ISO B6
CA90 U1 03	PCL	to	ISO B6

Flow curve - pressure loss

Pressure loss in bar. To convert Nm³/h to cfm use a coefficient of 0.588.

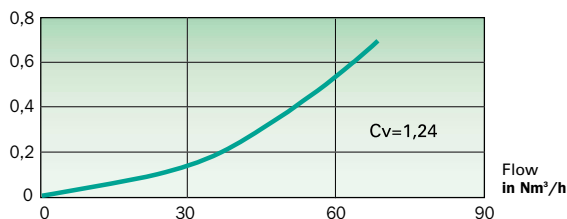

Materials

- **Body** : reinforced polymer
- **Sleeve** : reinforced polymer
- **Spring** : stainless steel
- **Seal** : nitrile
- **Thread** : nickel plated brass

- **Ball bearings** : stainless steel
- **Probe** : nickel plated brass
- **Probe adaptor** : nickel plated brass with polymer sleeve

Composite automatic safety couplers – ISO B profile - 8 mm

Transair® composite automatic safety couplers comply with worldwide **ISO 4414** and European EN983 safety standards. Disconnection is by a double twist of the sleeve – a safety feature that breaks deliberately with common practice in order to avoid accidental disconnection.

1st rotation in direction of the arrow : circuit rapidly-flushed out, probe side.



2nd rotation in direction of the arrow : safe disconnection of body and probe.

Flow : 2400 NI/min (85 cfm)

Safety

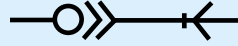

ISO 6150 B
AFNOR NF 49-053
US.MIL.C4109
CEJN 430
RECTUS 30

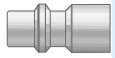

CP01 Male body, BSP parallel



C Transair®

G1/4	CP01 U2 02
G3/8	CP01 U2 03
G1/2	CP01 U2 04

Complete with sealing ring

CA87 Male probe, BSP parallel



C Transair®

G1/4	CA87 U2 02
G3/8	CA87 U2 03
G1/2	CA87 U2 04

Complete with sealing ring

CP14 Female body, BSP parallel



C Transair®

G1/4	CP14 U2 02
G3/8	CP14 U2 03
G1/2	CP14 U2 04

CA86 Female probe, BSP parallel



C Transair®

G1/4	CA86 U2 02
G3/8	CA86 U2 03
G1/2	CA86 U2 04

CP21 Body with hosetail



ØD Transair®

8	CP21 U2 08
10	CP21 U2 10
13	CP21 U2 13

Suitable for use with **Transair®** PVC hose (see p. 27)

CA94 Probe with hosetail



ØD Transair®

8	CA94 U2 08
10	CA94 U2 10
13	CA94 U2 13

Suitable for use with **Transair®** PVC hose (see p. 27)

Flow curve – pressure loss

Pressure loss in **bar**. To convert Nm³/h to cfm use a coefficient of 0.588.

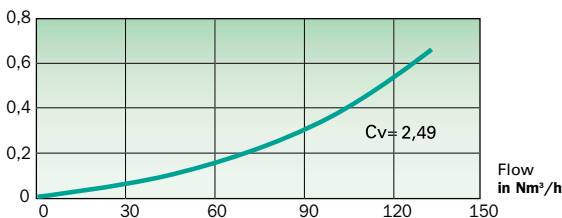

Materials

- **Body** : reinforced polymer
- **Sleeve** : reinforced polymer
- **Spring** : stainless steel
- **Seal** : nitrile
- **Ball bearings** : stainless steel
- **Probe** : nickel plated brass, nickel plated steel

Composite automatic safety couplers – European profile - 7,2 mm

- For quick and repetitive connection and disconnection
- 100% safety - **ISO 4414 and EN 983 compliant.**
- Very high flow, extremely small pressure loss
- Lightweight and robust
- Improved hand grip

- Fast vent time
- Suitable fluids : compressed air, argon, nitrogen (please consult us for other fluids)
- Working pressure : 16 bar maximum
- Working temperature : from -20°C to +60°C

Flow : 2000 NI/min (71 cfm)

Safety

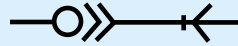

CEJN 320
RECTUS 25-26

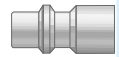

CP01 Male body, BSP parallel



C Transair®

G1/4	CP01 E4 02
G3/8	CP01 E4 03
G1/2	CP01 E4 04

Complete with sealing ring

CA87 Male probe , BSP parallel



C Transair®

G1/4	CA87 E4 02
G3/8	CA87 E4 03
G1/2	CA87 E4 04

Complete with sealing ring

CP14 Female body, BSP parallel



C Transair®

G1/4	CP14 E4 02
G3/8	CP14 E4 03
G1/2	CP14 E4 04

CA86 Female probe, BSP parallel



C Transair®

G1/4	CA86 E4 02
G3/8	CA86 E4 03
G1/2	CA86 E4 04

CP21 Body with hosetail



ØD Transair®

8	CP21 E4 08
10	CP21 E4 10
13	CP21 E4 13

Suitable for use with Transair® PVC hose (see p. 27)

CA94 Probe with hosetail



ØD Transair®

8	CA94 E4 08
10	CA94 E4 10
13	CA94 E4 13

Suitable for use with Transair® PVC hose (see p. 27)

Flow curve - pressure loss

Pressure loss in bar. To convert Nm³/h to cfm use a coefficient of 0.588.

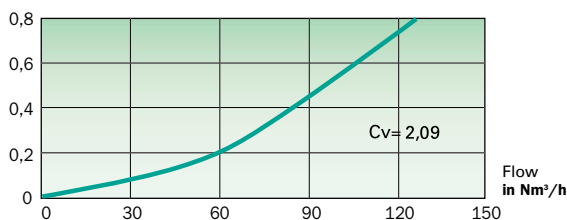

Materials

- **Body** : reinforced polymer
- **Sleeve** : reinforced polymer
- **Spring** : stainless steel
- **Seal** : nitrile
- **Ball bearings** : stainless steel
- **Probe** : nickel plated brass

Composite automatic safety couplers – ARO profile - 5,5 mm

Transair® composite automatic safety couplers comply with worldwide **ISO 4414** and European EN983 safety standards. Disconnection is by a double twist of the sleeve – a safety feature that breaks deliberately with common practice in order to avoid accidental disconnection.

1st rotation in direction of the arrow : circuit rapidly flushed out, probe side.



2nd rotation in direction of the arrow : safe disconnection of body and probe.

Flow : 1250 NI/min (44 cfm)

Safety

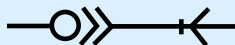

ARO 210
CEJN 300
ORION 44510
PARKER 50
RECTUS 14-22



CP01 Male body, BSP parallel



C Transair®

G1/4	CP01 A1 02
G3/8	CP01 A1 03
G1/2	CP01 A1 04

Complete with sealing ring

CA87 Male probe, BSP parallel



C Transair®

G1/4	CA87 A1 02
G3/8	CA87 A1 03
G1/2	CA87 A1 04

Complete with sealing ring

CP14 Female body, BSP parallel



C Transair®

G1/4	CP14 A1 02
G3/8	CP14 A1 03
G1/2	CP14 A1 04

CA86 Female probe, BSP parallel



C Transair®

G1/4	CA86 A1 02
G3/8	CA86 A1 03
G1/2	CA86 A1 04

CP21 Body with hosetail



ØD Transair®

6	CP21 A1 06
8	CP21 A1 08
10	CP21 A1 10

Suitable for use with **Transair®** PVC hose (see p. 27)

CA94 Probe with hosetail



ØD Transair®

6	CA94 A1 06
8	CA94 A1 08
10	CA94 A1 10

Suitable for use with **Transair®** PVC hose (see p. 27)

Flow curve – pressure loss

Pressure loss in **bar**. To convert Nm³/h to cfm use a coefficient of 0.588.

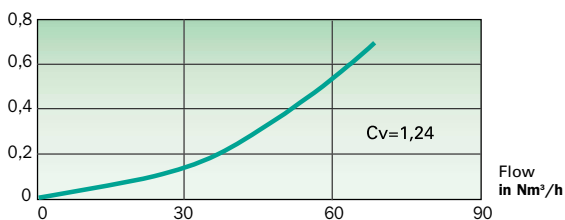

Materials

- **Body** : zamak
- **Sleeve** : reinforced polymer
- **Spring** : stainless steel
- **Seal** : nitrile
- **Ball bearings** : stainless steel
- **Probe** : nickel plated brass, nickel plated steel

Metal automatic safety couplers – ISO 6150B - 6 and 8 mm

- To avoid accidental separation and whiplash, disconnection takes place in 2 stages
- Suitable fluids : compressed air, **vacuum**, inert gas (argon, nitrogen) (please consult us for other fluids)
- Working pressure : 16 bar maximum
- **Vacuum** : 13 mbar - 750 mm Hg (98,7 % of vacuum)
- Working temperature : -20°C to +90°C

Flow :
6mm 1333 NI/min (47 cfm)
8mm 2333 NI/min (82 cfm)

Safety

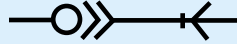

ISO 6150 B
 US.MIL.C4109
 CEJN 310-430
 RECTUS 23-24-30

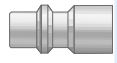

9D05 Male body, BSP taper



C	(DN)	Transair®
R1/4	5,5	9D05 09 13P4
R3/8	5,5	9D05 09 17P4
R1/2	5,5	9D05 09 21P4
R1/4	8	9D05 10 13P4
R3/8	8	9D05 10 17P4
R1/2	8	9D05 10 21P4

9084 Male thread, BSP taper



C	(DN)	Transair®
R1/4	5,5	9084 23 13TR
R3/8	5,5	9084 23 17TR
R1/4	8	9084 30 13TR
R3/8	8	9084 30 17TR
R1/2	8	9084 30 21TR

9D14 Female body, BSP parallel



C	(DN)	Transair®
G1/4	5,5	9D14 09 13P4
G3/8	5,5	9D14 09 17P4
G1/2	5,5	9D14 09 21P4
G1/4	8	9D14 10 13P4
G3/8	8	9D14 10 17P4
G1/2	8	9D14 10 21P4

9086 Female thread, BSP parallel



C	(DN)	Transair®
G1/4	5,5	9086 23 13TR
G3/8	5,5	9086 23 17TR
G1/4	8	9086 30 13TR
G3/8	8	9086 30 17TR
G1/2	8	9086 30 21TR

9D21 Body with hosetail



ØD	(DN)	Transair®
6	5,5	9D21 09 06P4
8	5,5	9D21 09 08P4
10	5,5	9D21 09 10P4
8	8	9D21 10 08P4
10	8	9D21 10 10P4

Suitable for use with **Transair®** PVC hose (see p. 27)

9085 Probe with hosetail



ØD	(DN)	Transair®
6	5,5	9085 23 06TR
8	5,5	9085 23 08TR
10	5,5	9085 23 10TR
8	8	9085 30 08TR
10	8	9085 30 10TR
13	8	9085 30 13TR

Suitable for use with **Transair®** PVC hose (see p. 27)

Materials

- **Body** : anodized duralumin
- **Probe** : nickel-plated steel
- **Spring** : stainless steel
- **Seal** : nitrile

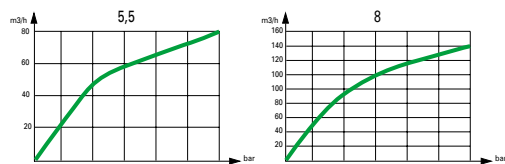

To convert Nm³/h to cfm use a coefficient of 0.588.

Metal automatic safety couplers - ISO 6150C - 6, 8 and 11 mm

- To avoid accidental separation and whiplash, disconnection takes place in 2 stages
- Suitable fluids : compressed air, inert gas (argon, nitrogen) (please consult us for other fluids)
- Working temperature : -20°C to +60°C

- Working pressure : passage 5,5 mm : from 0 to 12 bar
passage 8 mm : from 0 to 10 bar
passage 11 mm : from 0 to 8 bar

Flow :

6mm 1274 NI/min (45 cfm)

8mm 2633 NI/min (93 cfm)

11mm 5012 NI/min (177 cfm)

Safety

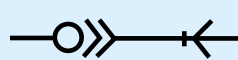

ISO 6150 C
NF E49-053
CEJN 29-381
RECTUS 18-84

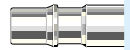

9D01 Male body, BSP parallel



Complete with sealing ring

C	DN	Transair®
G1/4	5,5	9D01 01 13P483
G3/8	5,5	9D01 01 17P483
G1/2	5,5	9D01 01 21P483
G1/4	8	9D01 02 13P483
G3/8	8	9D01 02 17P483
G1/2	8	9D01 02 21P483

9A87 Male thread, BSP parallel



Complete with sealing ring

C	DN	Transair®
G1/8	5,5	9A87 01 10X099
G1/4	5,5	9A87 01 13X099
G3/8	5,5	9A87 01 17X099
G1/4	8	9A87 02 13X099
G3/8	8	9A87 02 17X099
G1/2	8	9A87 02 21X099
G3/8	11	9A87 03 17X099
G1/2	11	9A87 03 21X099

9D14 Female body, BSP parallel



C	DN	Transair®
G1/4	5,5	9D14 01 13P483
G3/8	5,5	9D14 01 17P483
G1/2	5,5	9D14 01 21P483
G1/4	8	9D14 02 13P483
G3/8	8	9D14 02 17P483
G1/2	8	9D14 02 21P483
G3/8	11	9D14 03 17P483
G1/2	11	9D14 03 21P483

9A86 Female thread, BSP parallel



C	DN	Transair®
G1/8	5,5	9A86 01 10X099
G1/4	5,5	9A86 01 13X099
M14x1,25	5,5	9A86 01 70X099
G1/4	8	9A86 02 13X099
G3/8	8	9A86 02 17X099
G1/2	8	9A86 02 21X099
G3/8	11	9A86 03 17X099
G1/2	11	9A86 03 21X099

9D21 Body with hosetail



ØD	DN	Transair®
6	5,5	9D21 01 06P483
8	5,5	9D21 01 08P483
9	5,5	9D21 01 09P483
13	5,5	9D21 01 13P483
10	8	9D21 02 10P483
13	8	9D21 02 13P483
13	11	9D21 03 13P483
16	11	9D21 03 16P483

Suitable for use with Transair® PVC hose (see p. 27)

9A94 Probe with hosetail



ØD	DN	Transair®
6	5,5	9A94 01 06X099
8	5,5	9A94 01 08X099
10	5,5	9A94 01 10X099
13	5,5	9A94 01 13X099
6	8	9A94 02 06X099
8	8	9A94 02 08X099
10	8	9A94 02 10X099
13	8	9A94 02 13X099
8	11	9A94 03 08X099
13	11	9A86 03 13X099
16	11	9A86 03 16X099

Suitable for use with Transair® PVC hose (see p. 27)

Materials

- Body : anodized duralumin
- Probe : nickel-plated steel
- Spring : stainless steel
- Seal : nitrile

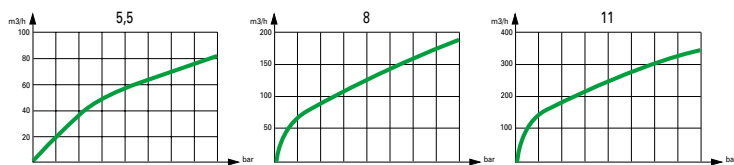

To convert Nm³/h to cfm use a coefficient of 0,588.

Metal automatic safety couplers - ISO 6150C - 6 mm

- Single shut-off : when disconnecting the body and the probe cannot be separated as long as the button is depressed, allowing downstream pressure to be manually vented.
- Suitable fluid : compressed air
- Working pressure : from 0 to 10 bar
- Working temperature : -20°C to +60°C

Single shut-off

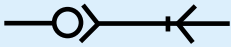

ISO 6150 C
NF E49-053
CEJN 291
RECTUS 18

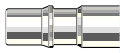

Flow 6mm 1160 NI/min (41 cfm)

9D01 Male body, BSP parallel



Complete with sealing ring

C	DN	Transair®
G1/4	5,5	9D01 01 13P183
G3/8	5,5	9D01 01 17P183
G1/2	5,5	9D01 01 21P183

9A87 Male threaded, BSP parallel



Complete with sealing ring

C	DN	Transair®
G1/8	5,5	9A87 01 10X099
G1/4	5,5	9A87 01 13X099
G3/8	5,5	9A87 01 17X099
G1/4	8	9A87 02 13X099
G3/8	8	9A87 02 17X099
G1/2	8	9A87 02 21X099
G3/8	11	9A87 03 17X099
G1/2	11	9A87 03 21P183

9D14 Female body, BSP parallel



C	DN	Transair®
G1/8	5,5	9D14 01 10P183
G1/4	5,5	9D14 01 13P183
G3/8	5,5	9D14 01 17P183

9A86 Female thread, BSP parallel



C	DN	Transair®
G1/8	5,5	9A86 01 10X099
G1/4	5,5	9A86 01 13X099
M14x1,25	5,5	9A86 01 70X099
G1/4	8	9A86 02 13X099
G3/8	8	9A86 02 17X099
G1/2	8	9A86 02 21X099
G3/8	11	9A86 03 17X099
G1/2	11	9A86 03 21X099

9D21 Body with hosetail



ØD	DN	Transair®
10	5,5	9D21 01 10P183

Suitable for use with Transair® PVC hose (see p. 27)

9A94 Probe with hosetail



ØD	DN	Transair®
6	5,5	9A94 01 06X099
8	5,5	9A94 01 08X099
10	5,5	9A94 01 10X099
13	5,5	9A94 01 13X099
6	8	9A94 02 06X099
8	8	9A94 02 08X099
10	8	9A94 02 10X099
13	8	9A94 02 13X099
8	11	9A94 03 08X099
13	11	9A86 03 13X099
16	11	9A86 03 16X099

Suitable for use with Transair® PVC hose (see p. 27)

Materials

- **Body** : anodized duralumin
- **Probe** : nickel-plated steel
- **Spring** : stainless steel
- **Seal** : nitrile

To convert Nm³/h to cfm use a coefficient of 0.588.

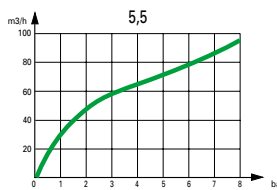

Hose reels - Blowgun

Hose reels

- Optimize productivity and the safety of your workstations
- Prevent hose damage occurring on the workshop floor
- Maximum working pressure, dependant on the model :
 - 6698 10 01 : 12 bar
 - 6698 10 02 : 15 bar
 - 6698 11 01 : 20 bar
- Working temperature : -5°C to +40°C

Blowgun

- Dusting, cooling and drying components
- Cleaning swarf
- Cleaning machinery
- Working pressure : 12 bar maximum
- Working temperature : -20°C to +50°C

6698 Light series hose reel, 10 m

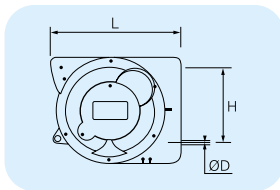

ØD	Transair®	Hose i.d. (mm)	Max hose pressure (bar)	H	L	kg
10,5	6698 10 01	7,5	12	251	300	3,8

Enclosed case
Hose clutch with free return
Outlet connection G1/4 male

6698 Heavy duty series hose reel, 18 m

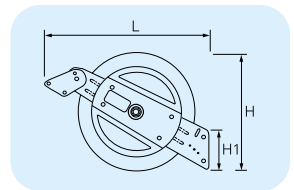

ØD	Transair®	Hose i.d. (mm)	Max hose pressure (bar)	H	L	kg
	6698 11 01	10	20	430	600	15,4

Open case with roller guides
Hose clutch with free return
Outlet connection G1/2 male

6698 Light series hose reel, 16 m

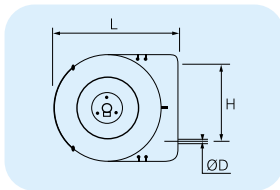

ØD	Transair®	Hose i.d. (mm)	Max hose pressure (bar)	H	L	kg
10,5	6698 10 02	8	15	251	390	9,0

Enclosed case
Hose clutch with free return
Outlet connection G3/8 male

EA59 Blowgun

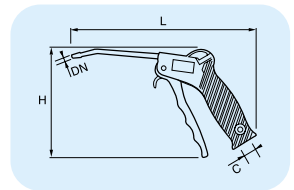

C	ØD	Transair®	H	L	kg
G1/4	3,5	EA59 00 13	125,5	223,0	0,075

Flow 6 bar : 430 NI/min. (26.6 m³/h) (15cfm)

Hose reels can be easily connected to a Transair® air pipework system by the use of a threaded Quick Assembly Mini Bracket – see page 7.

Materials

- **Light series hose reels** : - polyurethane hose 10m or 16 m long ; case : high impact plastic ; fixing base : black metal
- **Heavy duty hose reel** : - polyurethane hose 18m long ; case : metal ; fixing base : brass and stainless steel
- **Blowgun** : - body : reinforced composite ; nozzle : aluminium

Connection accessories

- Offering many possible configurations in BSP parallel and taper
- For connection to ancillary equipment on wall brackets or assembly brackets
- For compressor outlets, dryers or receivers
- Suitable fluids : compressed air (dry, wet and lubricated), inert gas (argon, nitrogen), industrial vacuum (other fluids, please consult us)
- Working pressure : 16 bar maximum
- Vacuum capability : 1.3 mbar (98,7%)
- Working temperature : -10°C to +80°C

EF00 Straight male, BSPT equal/unequal adaptor

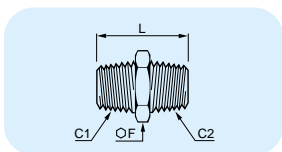

C1	C2	Transair®	F	L
R1/4	R1/4	EF00 00 02	14	27
R1/4	R3/8	EF00 02 03	17	27,5
R3/8	R3/8	EF00 00 03	17	28
R1/4	R1/2	EF00 02 04	22	30,5
R3/8	R1/2	EF00 03 04	22	31
R1/2	R1/2	EF00 00 04	22	33,5
R1/2	R3/4	EF00 04 06	27	37,5
R3/4	R3/4	EF00 00 06	27	40
R3/4	R1"	EF00 06 08	34	43
R1"	R1"	EF00 00 08	34	45,5
R1"	R1"1/4	EF00 08 10	42	40,5
R1"1/4	R1"1/4	EF00 00 10	42	43
R1"1/4	R1"1/2	EF00 10 12	48	44
R1"1/4	R2"	EF00 10 16	60	49
R1"1/2	R1"1/2	EF00 00 12	48	44
R1"1/2	R2"	EF00 12 16	60	49
R1"1/2	R2"1/2	EF00 12 20	75	52,5
R2"	R2"	EF00 00 16	60	52
R2"	R2"1/2	EF00 16 20	75	54,5
R2"1/2	R2"1/2	EF00 00 20	75	58

EF02 Straight female, BSPP equal/unequal adaptor

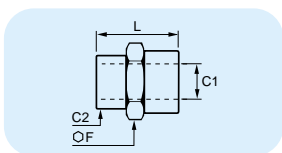

C1	C2	Transair®	F	L
G1/8	G1/4	EF02 01 02	17	19,5
G1/4	G1/4	EF02 00 02	17	22
G1/8	G3/8	EF02 01 03	22	20
G1/4	G3/8	EF02 02 03	22	23
G3/8	G3/8	EF02 00 03	22	24
G1/4	G1/2	EF02 02 04	27	27
G3/8	G1/2	EF02 03 04	27	27,5
G1/2	G1/2	EF02 00 04	27	30
G1/2	G3/4	EF02 04 06	30	30
G3/4	G3/4	EF02 00 06	30	32

EF06 Increaser male BSPT to female BSPP

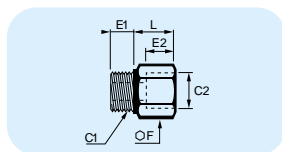

C1	C2	Transair®	E1	E2	F	L
R1/8	G1/4	EF06 01 02	6	11,5	17	14
R1/8	G3/8	EF06 01 03	6	11,5	22	14,5
R1/4	G1/4	EF06 00 02	8	11,5	17	14
R1/4	G3/8	EF06 02 03	8	11,5	22	14,5
R1/4	G1/2	EF06 02 04	8	15	27	18
R3/8	G3/8	EF06 00 03	9	11,5	22	14,5
R3/8	G1/2	EF06 03 04	9	15	27	18
R1/2	G1/2	EF06 00 04	10	15	27	18
R1/2	G3/4	EF06 04 06	11,5	10,5	29	24
R1/2	G1"	EF06 04 08	11,5	12	36	26,5
R3/4	G3/4	EF06 00 06	13	10,5	29	25,5
R3/4	G1"	EF06 06 08	13	12,5	36	28
R1"	G1"	EF06 00 08	15	12,5	36	30
R1"	G1"1/4	EF06 08 10	15	14	45	32
R1"1/4	G1"1/4	EF06 00 10	17,5	14	45	34,5
R1"1/4	G1"1/2	EF06 10 12	17,5	15	52	35,5
R1"1/4	G2"	EF06 10 16	17,5	16	64	36,5
R1"1/2	G1"1/2	EF06 00 12	17,5	15	52	35,5
R1"1/2	G2"	EF06 12 16	17,5	16	64	36,5
G1"1/2	G2"1/2	EF06 12 20	17,5	19	80	39,5
G2"	G2"	EF06 00 16	20,5	16	64	39,5
G2"	G2"1/2	EF06 16 20	20,5	19	80	42,5
G2"1/2	G2"1/2	EF06 00 20	23	19	80	45

EF04 Reducer male BSPT to female BSPP

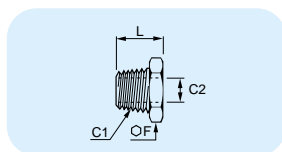

C1	C2	Transair®	F	L
R1/4	G1/8	EF04 01 02	14	16
R3/8	G1/8	EF04 01 03	17	16,5
R3/8	G1/4	EF04 02 03	17	16,5
R1/2	G1/4	EF04 02 04	22	19,5
R1/2	G3/8	EF04 03 04	22	19,5
R3/4	G3/8	EF04 03 06	27	23,5
R3/4	G1/2	EF04 04 06	27	23,5

Materials

- nickel-plated brass
- 100 % recyclable

EF12 Equal female elbow BSPP

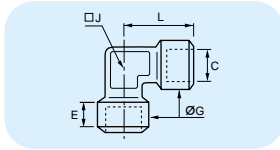

C	Transair®	E	G	J	L
G1/4	EF12 00 02	11	17	13	25,5
G3/8	EF12 00 03	11,5	21	17	28
G1/2	EF12 00 04	14	26	21	33,5
G3/4	EF12 00 06	15	31	27	36,5

EF15 Equal female tee BSPP

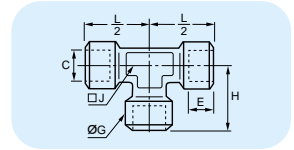

C	Transair®	E	G	H	J	L/2
G1/4	EF15 00 02	11	17	25,5	13	25,5
G3/8	EF15 00 03	11,5	21	28	17	28
G1/2	EF15 00 04	14	26	33,5	21	33,5
G3/4	EF15 00 06	15	31	36,5	27	36,5

EF13 Equal female stud elbow BSPP, male BSPT

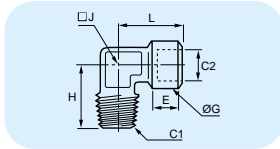

C1	C2	Transair®	E	G	H	J	L
R1/4	G1/4	EF13 00 02	11	17	23,5	13	25,5
R3/8	G3/8	EF13 00 03	11,5	21	26	17	28
R1/2	G1/2	EF13 00 04	14	26	31	21	33,5
R3/4	G3/4	EF13 00 06	15	31	35	27	36,5

EF16 Male stud branch tee, female BSPP, male BSPT

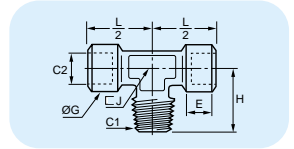

C1	C2	Transair®	E	G	H	J	L/2
R1/4	G1/4	EF16 00 02	17	17	23,5	13	25,5
R3/8	G3/8	EF16 00 03	11,5	21	26	17	28
R1/2	G1/2	EF16 00 04	14	26	31	21	33,5
R3/4	G3/4	EF16 00 06	15	31	35	27	36,5

EF14 Equal male stud elbow BSPT

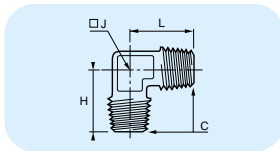

C	Transair®	H	J	L
R1/4	EF14 00 02	23,5	13	23,5
R3/8	EF14 00 03	26	17	26
R1/2	EF14 00 04	31	21	31
R3/4	EF14 00 06	35	27	35

Materials

- nickel-plated brass
- 100 % recyclable

Connection accessories

EF17 Male stud run tee, female BSPP, male BSPT

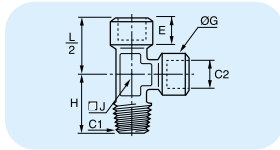

C1	C2	Transair®	E	G	H	J	L/2
R1/4	G1/4	EF17 00 02	11	17	23,5	13	25,5
R3/8	G3/8	EF17 00 03	11,5	21	26	17	28
R1/2	G1/2	EF17 00 04	14	26	31	21	33,5
R3/4	G3/4	EF17 00 06	15	31	36,5	27	36,5

EF26 Tailpiece adaptor for PVC hose, male BSPP

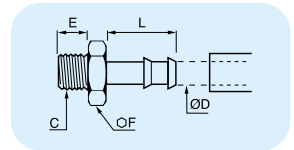

ØD	C	Transair®	E	F	L
6	G1/8	EF26 06 01	6	12	20
6	G1/4	EF26 06 02	8	17	21
8	G1/4	EF26 08 02	8	17	21
8	G3/8	EF26 08 03	9	19	21
10	G1/4	EF26 10 02	8	14	20
10	G3/8	EF26 10 03	9	19	20
10	G1/2	EF26 10 04	10	22	20
13	G1/4	EF26 13 02	8	17	21
13	G3/8	EF26 13 03	9	19	22
13	G1/2	EF26 13 04	10	24	25
16	G3/8	EF26 16 03	9	19	21
16	G1/2	EF26 16 04	10	24	25

Supplied with captive sealing washer. Ideally suited to Transair® PVC hose (see p. 27).

EF10 Equal Y, female BSPP

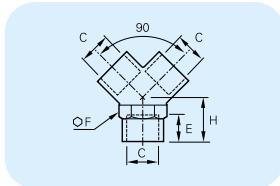

C	Transair®	E	F	H
G1/4	EF10 00 02	11	17	14
G3/8	EF10 00 03	11,5	20	16
G1/2	EF10 00 04	14	25	19

EF11 Equal Y, female BSPP, male BSPT

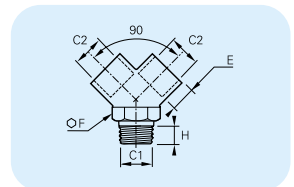

C1	C2	Transair®	E	F	H
R1/2	G1/2	EF11 00 04	14	25	19

Materials

- nickel plated brass
- 100% recyclable

Tubes and Hoses

Braided PVC hose

- Resistant and well adapted to the supply of machinery and hose reels, etc....
- Suitable fluid : compressed air
- Working pressure at 23°C : 20 bar
- Working temperature : -15°C to +60°C

Polyurethane recoil tubing

- Extremely compact, due to small diameter of spirals, **Transair®** polyurethane recoil tubing is perfectly suited to installations requiring flexibility in a reduced space. Its straightened extremities and its good resistance to shocks and abrasion enable the user safe and easy manipulation of machinery.
- Suitable fluid : compressed air
- Maximum working pressure at 20°C : 10 bar

1025V Braided PVC hose



i.d. x o.d. (mm)	Bend radius (mm)	Working pressure at 23°C (bar)	Maximum non-burst pressure at 23°C (bar)	Transair®	kg
6 x 12	50	20	63	1025V12 04 06TR	2,725
8 x 14	65	20	63	1025V14 04 08TR	3,250
10 x 16	75	20	63	1025V16 04 10TR	3,875
13 x 20	90	20	63	1025V20 04 13TR	5,625
16 x 24	125	20	63	1025V24 04 16TR	7,875

0697 Clip for braided hose

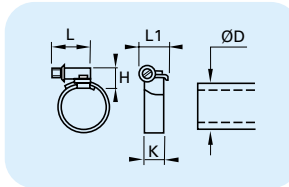

ØD	Transair®	H	K	L	L1	kg
12	0697 00 02TR	12	9	21	13	0,010
14	0697 00 02TR	12	9	21	13	0,010
16	0697 00 03TR	12	9	24	13	0,013
20	0697 00 04TR	12	9	24	13	0,014
24	0697 00 05TR	12	9	24	13	0,014

1470U / 1471U / 1472U Polyurethane recoil tubing, 2m, 4m, 6m extended length



o.d. tube (mm)	i.d. tube (mm)	BSPT thread	Length of long straight section (mm)	Length of short straight section (mm)	Ø of the spiral in mm	Transair®		Transair®		Transair®	
						2 m long	Length of spiral in mm	4 m long	Length of spiral in mm	6 m long	Length of spiral in mm
6	4	1/4	300	100	32	1470U06 04 13TR	630	1471U06 04 13TR	850	-	-
8	5	1/4	500	100	42	1470U08 04 13TR	780	1471U08 04 13TR	1000	1472U08 04 13TR	1230
10	7	1/4	500	100	62	1470U10 04 13TR	780	1471U10 04 13TR	1000	1472U10 04 13TR	1140
12	8	3/8	500	100	65	1470U12 04 17TR	780	1471U12 04 17TR	990	1472U12 04 17TR	1190

Materials

PVC hose reinforced by a high resistance textile braid
 0697 clip and screw : zinc plated steel

FRLs, Automatic drain and accessories

Transair® FRLs are ideal for general purpose use and can be fitted downstream of the compressed air installation and at take-off points on workstations and machines :

- Air quality at FRL inlet : dry, damp, oiled
- Chemical resistance to compressor oils

- **Transair®** FRL products are guaranteed silicone free

To convert Nm³/h to cfm use a coefficient of 0.588.

6700 Filter regulator



6700 00 13 : model for G1/4
6700 00 21 : model for G1/2
Maxi inlet pressure : 16 bar - **Max outlet pressure** : 8 bar
Temperature : 0°C to +50°C (to 10 bar)
Semi-automatic condensate drainage
Filtration : 30 µm
Recommended flow : G1/4 = 33m³/h - G1/2 = 114m³/h
Bowl capacity : G1/4 = 22cm³ - G1/2 = 50cm³
 To be used with gauge : **6798 00 05** for G1/4
6798 00 06 for G1/2

6706 Automatic drain



6706 00 21 : model for G1/2
Condensate drain : - automatic
 - float type

6701 Pressure regulator



6701 00 13 : model for G1/4
6701 00 21 : model for G1/2
Maxi inlet pressure : 16 bar - **Max outlet pressure** : 8 bar
Temperature : 0°C to +60°C
Recommended flow : G1/4 = 33m³/h - G1/2 = 114m³/h
 To be used with gauge : **6798 00 05** for G1/4
6798 00 06 for G1/2

6707 Filter regulator lubricator set



6700 00 13 : model for G1/4
6700 00 21 : model for G1/2
Maxi inlet pressure : 16 bar - **Max outlet pressure** : 8 bar
Temperature : 0°C to +50°C (to 10 bar)
Semi-automatic condensate drainage
Filtration : 30 µm
Recommended flow : G1/4 = 33m³/h - G1/2 = 114m³/h
Max bowl capacity : G1/4 = 22cm³ - G1/2 = 50cm³
 With flow compensation.

6702 Filter separator



6702 00 13 : model for G1/4
6702 00 21 : model for G1/2
Maxi inlet pressure : 16 bar - **Max outlet pressure** : 8 bar
Temperature : 0°C to +50°C (to 10 bar)
Semi-automatic condensate drainage
Filtration : 30 µm
Recommended flow : G1/4 = 33m³/h - G1/2 = 114m³/h
Bowl capacity : G1/4 = 22cm³ - G1/2 = 50cm³

6708 Filter regulator and lubricator with gauge



6700 00 13 : model for G1/4
6700 00 21 : model for G1/2
Maxi inlet pressure : 16 bar - **Max outlet pressure** : 8 bar
Temperature : 0°C to +50°C (to 10 bar)
Semi-automatic condensate drainage
Filtration : 30 µm
Recommended flow : G1/4 = 33m³/h - G1/2 = 114m³/h
Max bowl capacity : G1/4 = 22cm³ - G1/2 = 50cm³
 With flow compensation.

6703 Lubricator



6703 00 13 : with G1/4 port
6703 00 21 : with G1/2 port
 Oil mist lubricator
Max inlet pressure : 16 bar - **Max outlet pressure** : 8 bar
Temperature : -20°C to +50°C (to 10 bar)
Oil capacity : G1/4 = 45cm³ - G1/2 = 112cm³
 With flow compensation.

6798 Gauge

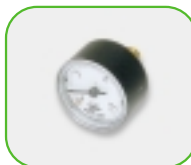

6798 00 05 : G1/8 thread for FRL 1/4 - 40 mm gauge diameter
6798 00 06 : G1/4 thread for FRL 1/2 - 50 mm gauge diameter
 To be mounted on the front face of the filter regulator or the regulator.

6704 3/2 in-line vent valve

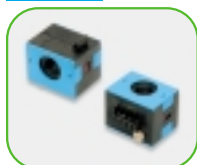

6704 00 13 : with G1/4 port
6704 00 21 : with G1/2 port
 3/2 lockable shut-off valve
Min pressure : 0 bar - **Max pressure** : 16 bar
Temperature : 0°C à +60°C
Downstream circuit drains when valve is closed
Recommended flow : G1/4 = 33m³/h - G1/2 = 114m³/h
 Supplied without padlock.

6798 Protection bowl



6798 00 07 : model with G1/4 thread, with snap mounting
6798 00 08 : model with G1/2 thread, with snap mounting
 To be used with filter regulator, filter, lubricator.

6705 Front and rear port connector block

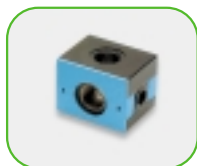

6705 00 13 : with G1/4 port
6705 00 21 : with G1/2 port
 To be used when assembling 2 elements front and rear entry : G1/8 and G1/4.

6798 Mounting brackets and assembly kit



6798 00 01 : with G1/4 port
6798 00 02 : with G1/2 port
 For wall or machine fixing.
 Screws supplied.
 Centre-to-centre : 46 mm (compatible with **Transair®** fixing clips).
Assembly kit, to assemble several elements.
6798 00 03 : with G1/4 port
6798 00 04 : with G1/2 port

All products presented above can be easily connected to **Transair®**, compressed air pipework systems using the following **Transair®** stud fittings :

- **6605 17 13** for G1/4 port (page 4)
- **6605 17 21** or **6605 25 21** for G1/2 port (page 4)

Instructions

1 • Areas of application

Before installing **Transair®**, a responsible person should check that the area of installation conforms to regulations designed to prevent the risk of explosion (in particular the risks associated within silo zones)

Transair® must be installed either after the air receiver or after the dryer. Flexible **Transair®** hose should be fitted at the beginning of the pipe system, in order to counter the vibrations found in any compressed air system. When maintaining or modifying the **Transair®** pipe system the work must be undertaken only after the compressed air system has been vented. The installer must use only **Transair®** components and accessories, and in particular, **Transair®** fixing clips. No other type of fixing method is to be used. The technical characteristics of **Transair®** components as expressed in this catalogue must be respected.

2 • Starting the installed system

Once assembled, the operation of the **Transair®** installation is the responsibility of the installer who, prior to use, must complete all necessary tests.

The installer must also ensure that the installation has been properly carried out in line with the instructions and that it meets all legal requirements.

3 • Transair® pipe

Care should be taken to protect pipes against mechanical shocks – especially when close to the passage of fork-lift trucks or where suspended objects are being moved. Equally all excessive rotational movements which could lead to disconnection, whether on the pipes or the supports, must be avoided.

Transair® rigid pipes must not be bent (formed) or welded. Flexible **Transair®** hose must be used in accordance with the instructions in this catalogue.

4 • Contraction/expansion

The performance of the **Transair®** system is maintained when the effects of expansion or contraction are properly taken into account.

5 • Assembling the components

To ensure proper installation **Transair®** components are supplied with an "Assembly Guide". The installer must follow with care the precise instructions as described in this guide as well as this catalogue

6 • Supports

When suspending from a ceiling **Transair®** clips should be fixed to a rigid support (U channel, cable tray, threaded rod, etc).

This type of support ensures that the clips stay in alignment which allows the pipe to expand and contract.

7 • Observations

When using **Transair®** the following situations must be avoided :

- embedded in a solid mass (concrete, injected foam)
- fixing other external elements to **Transair®** pipe (other than blowguns, plastic tubes etc with a maximum weight of 20 kgs between 2 clips).
- the use of **Transair®** as an electric earthing or to support electrical material.
- the use of **Transair®** with non-compatible components.

(Please consult us).

Select the Transair® diameter for your application based on required flow and pressure drop.

Values are for a pressure of 8 bar, 5% pressure drop.

Flow			Length									
			65,6 ft	131,2 ft	328 ft	656 ft	984 ft	1312 ft	1640 ft	3280 ft	4920 ft	6560 ft
m³/h	l/min	cfm	20 m	40 m	100 m	200 m	300 m	400 m	500 m	1000 m	1500 m	2000 m
10	167	6	16,5	16,5	16,5	16,5	16,5	16,5	16,5	16,5	16,5	16,5
30	500	18	16,5	16,5	16,5	25	25	25	25	25	25	25
50	833	29	16,5	16,5	25	25	25	25	25	25	25	40
100	1667	59	16,5	25	25	25	25	25	40	40	40	40
200	3333	118	25	25	25	40	40	40	40	40	40	63
300	5000	177	25	25	40	40	40	40	40	40	63	63
400	6667	236	25	40	40	40	40	40	63	63	63	63
500	8333	294	40	40	40	40	40	63	63	63	63	63
600	10000	353	40	40	40	63	63	63	63	63	63	63
700	11667	412	40	40	40	63	63	63	63	63	63	63*
800	13333	471	40	40	63	63	63	63	63	63	63*	63*
900	15000	530	40	40	63	63	63	63	63	63*	63*	63*
1000	16667	589	40	40	63	63	63	63	63	63*	63*	63*
1250	20833	736	40	63	63	63	63	63	63*	63*	63*	63*
1500	25000	883	40	63	63	63	63	63*	63*	63*	63*	63*
1750	29167	1031	63	63	63	63	63*	63*	63*	63*	63*	63*

*pressure drop over 5%.

Index

Part number	Page	Part number	Page	Part number	Page	Part number	Page	Part number	Page	Part number	Page
0000 01 68	6	6606 25 00	4	6698 04 02	10	9A87 02 13X099	21, 22	CA87 U1 03	16	EF02 00 03	24
0697 00 02TR	27	6606 40 00	4	6698 04 03	11	9A87 02 17X099	21, 22	CA87 U1 04	16	EF02 00 04	24
0697 00 03TR	27	6606 63 00	4	6698 05 03	11	9A87 02 21X099	21, 22	CA87 U2 02	17	EF02 00 06	24
0697 00 04TR	27	6607 25 00	5	6698 10 01	23	9A87 03 17X099	21, 22	CA87 U2 03	17	EF02 01 02	24
0697 00 05TR	27	6612 25 00	4	6698 10 02	23	9A87 03 21X099	21, 22	CA87 U2 04	17	EF02 01 03	24
1001E25 00 01	6	6612 40 00	4	6698 11 01	23	9A94 01 06X099	21, 22	CA94 U1 01	16	EF02 02 03	24
1001E25 00 03	6	6621 17 21	5	6698 99 03	6	9A94 01 08X099	21, 22	CA90 U1 03	16	EF02 02 04	24
1001E25 00 04	6	6621 25 21	5	6699 01 01	12	9A94 01 10X099	21, 22	CA94 A1 06	19	EF02 03 04	24
1001E25V00 01	6	6621 25 27	5	6699 01 02	12	9A94 01 13X099	21, 22	CA94 A1 08	19	EF02 04 06	24
1001E25V00 03	6	6621 40 42	5	6699 01 03	12	9A94 02 06X099	21, 22	CA94 A1 10	19	EF04 01 02	24
1001E25V00 04	6	6621 40 49	5	6699 02 01	13	9A94 02 08X099	21, 22	CA94 E4 08	18	EF04 01 03	24
1001E40 00 02	6	6625 17 00	5	6699 02 02	13	9A94 02 10X099	21, 22	CA94 E4 10	18	EF04 02 03	24
1001E40 00 04	6	6625 25 00	5	6699 02 03	13	9A94 02 13X099	21, 22	CA94 E4 13	18	EF04 02 04	24
1001E40 00 05	6	6625 40 00	5	6699 02 04	13	9A94 03 08X099	21, 22	CA94 U1 06	16	EF04 03 04	24
1001E40V00 04	6	6625 63 00	5	6699 02 05	13	9A94 03 13X099	21, 22	CA94 U1 08	16	EF04 03 06	24
1001E40V00 05	6	6651 25 12 04	5	6699 02 06	13	9A94 03 16X099	21, 22	CA94 U1 10	16	EF04 04 06	24
1001E40V00 07	6	6651 40 12 04	5	6699 03 01	13	9D01 01 13P183	22	CA94 U2 08	17	EF06 00 02	24
1001E63 00 05	6	6660 25 A1	7	6699 03 02	13	9D01 01 13P483	21	CA94 U2 10	17	EF06 00 03	24
1001E63 00 06	6	6660 25 E4	7	6699 04 01	14	9D01 01 17P183	22	CA94 U2 13	17	EF06 00 04	24
1001E63 00 08	6	6660 25 U1	7	6699 04 02	14	9D01 01 17P483	21	CP01 A1 02	19	EF06 00 06	24
1001E63V00 05	6	6660 25 U2	7	6699 04 60	14	9D01 01 21P183	22	CP01 A1 03	19	EF06 00 08	24
1001E63V00 06	6	6660 40 A1	7	6699 04 60 01	14	9D01 01 21P483	21	CP01 A1 04	19	EF06 00 10	24
1003A17 04 00	6	6660 40 E4	7	6699 04 63	14	9D01 02 13P483	21	CP01 E4 02	18	EF06 00 12	24
1003A25 04 00	6	6660 40 U1	7	6699 04 64	15	9D01 02 17P483	21	CP01 E4 03	18	EF06 00 16	24
1003A40 04 00	6	6660 40 U2	7	6699 04 65	15	9D01 02 21P483	21	CP01 E4 04	18	EF06 00 20	24
1003A63 04 00	6	6660 63 A1	7	6699 10 01	13	9D05 09 13P4	20	CP01 U1 02	16	EF06 01 02	24
1006A25 04 00	6	6660 63 E4	7	6699 10 02	13	9D05 09 17P4	20	CP01 U1 03	16	EF06 01 03	24
1006A40 04 00	6	6660 63 U1	7	6699 10 03	13	9D05 09 21P4	20	CP01 U1 04	16	EF06 02 03	24
1006A63 04 00	6	6660 63 U2	7	6699 11 01	13	9D05 10 13P4	20	CP01 U2 02	17	EF06 02 04	24
1025V12 04 06TR	27	6661 25 21	7	6700 00 13	28	9D05 10 17P4	20	CP01 U2 03	17	EF06 03 04	24
1025V14 04 08TR	27	6661 40 21	7	6700 00 21	28	9D05 10 21P4	20	CP01 U2 04	17	EF06 04 06	24
1025V16 04 10TR	27	6661 63 21	7	6701 00 13	28	9D14 01 10P183	22	CP14 A1 02	19	EF06 04 08	24
1025V20 04 13TR	27	6661 63 27	7	6701 00 21	28	9D14 01 13P183	22	CP14 A1 03	19	EF06 06 08	24
1025V24 04 16TR	27	6662 25 00	7	6702 00 13	28	9D14 01 13P483	21	CP14 A1 04	19	EF06 08 10	24
1470U06 04 13TR	27	6662 25 17	7	6702 00 21	28	9D14 01 17P183	22	CP14 E4 02	18	EF06 10 12	24
1470U08 04 13TR	27	6662 40 00	7	6703 00 13	28	9D14 01 17P483	21	CP14 E4 03	18	EF06 10 16	24
1470U10 04 13TR	27	6662 40 17	7	6703 00 21	28	9D14 01 21P483	21	CP14 E4 04	18	EF06 12 16	24
1470U12 04 17TR	27	6662 40 25	7	6704 00 13	28	9D14 02 13P483	21	CP14 U1 02	16	EF06 12 20	24
1471U06 04 13TR	27	6662 63 25	7	6704 00 21	28	9D14 02 17P483	21	CP14 U1 03	16	EF06 16 20	24
1471U08 04 13TR	27	6666 17 25	5	6705 00 13	28	9D14 02 21P483	21	CP14 U1 04	16	EF10 00 02	26
1471U10 04 13TR	27	6666 25 40	5	6705 00 21	28	9D14 03 17P483	21	6CP14 U2 02	17	EF10 00 03	26
1471U12 04 17TR	27	6666 40 63	5	6706 00 21	28	9D14 03 21P483	21	CP14 U2 03	17	EF10 00 04	26
1472U08 04 13TR	27	6670 17 A1	9	6707 00 13	28	9D14 09 13P4	20	CP14 U2 04	17	EF11 00 04	26
1472U10 04 13TR	27	6670 17 E4	9	6707 00 21	28	9D14 09 17P4	20	CP21 A1 06	19	EF12 00 02	25
1472U12 04 17TR	27	6670 17 U1	9	6708 00 13	28	9D14 09 21P4	20	CP21 A1 08	19	EF12 00 03	25
3114 14 17TR	15	6670 17 U2	9	6708 00 21	28	9D14 10 13P4	20	CP21 A1 10	19	EF12 00 04	25
3126 14 00TR	15	6670 25 A1	9	6798 00 01	28	9D14 10 17P4	20	CP21 E4 08	18	EF12 00 06	25
4002 40 00	8	6670 25 E4	9	6798 00 02	28	9D14 10 21P4	20	CP21 E4 10	18	EF13 00 02	25
4002 63 00	8	6670 25 U1	9	6798 00 03	28	9D21 01 06P483	21	CP21 E4 13	18	EF13 00 03	25
4012 63 00	8	6670 25 U2	9	6798 00 04	28	9D21 01 08P483	21	CP21 U1 06	16	EF13 00 04	25
4089 17 00	8	6671 17 A1	9	6798 00 05	28	9D21 01 09P483	21	CP21 U1 08	16	EF13 00 06	25
4089 25 00	8	6671 17 E4	9	46798 00 06	28	9D21 01 10P183	22	CP21 U1 10	16	EF14 00 02	25
4099 17 00	8	6671 17 U1	9	6671 17 U1	9	9D21 01 13P483	21	CP21 U2 08	17	EF14 00 03	25
4099 25 00	8	6671 17 U2	9	6798 00 08	9	9D21 02 10P483	21	CP21 U2 10	17	EF14 00 04	25
4230 00 40	8	6671 25 A1	9	9084 23 13TR	20	9D21 02 13P483	21	CP21 U2 13	17	EF14 00 06	25
4299 03 01	8	6671 25 E4	9	9084 23 17TR	20	9D21 03 13P483	21	EA59 00 13	23	EF15 00 02	25
4934 20 27TR	8	6671 25 U1	9	9084 30 13TR	20	9D21 03 16P483	21	EA98 06 00	11	EF15 00 03	25
4934 25 34TR	8	6671 25 U2	9	9084 30 17TR	20	9D21 09 06P4	20	EA98 06 01	11	EF15 00 04	25
4934 32 42TR	8	6676 25 00	4	9084 30 21TR	20	9D21 09 08P4	20	EA98 06 02	11	EF15 00 06	25
4934 40 49TR	8	6676 40 00	4	9085 23 06TR	20	9D21 09 10P4	20	EA98 06 03	11	EF16 00 02	25
4981 10 21TR	8	6676 63 00	4	9085 23 08TR	20	9D21 10 08P4	20	EF00 00 02	24	EF16 00 03	25
6602 17 00	4	6680 17 21	9	9085 23 10TR	20	9D21 10 10P4	20	EF00 00 03	24	EF16 00 04	25
6602 25 00	4	6680 25 21	9	9085 30 08TR	20	CA86 A1 02	19	EF00 00 04	24	EF16 00 06	25
6602 40 00	4	6681 17 21	9	9085 30 10TR	20	CA86 A1 03	19	EF00 00 06	24	EF17 00 02	26
6602 63 00	4	6681 25 21	9	9085 30 13TR	20	CA86 A1 04	19	EF00 00 08	24	EF17 00 03	26
6604 17 00	4	6685 21 21	9	9086 23 13TR	20	CA86 E4 02	18	EF00 00 10	24	EF17 00 04	26
6604 25 00	4	6686 21 21	9	9086 23 17TR	20	CA86 E4 03	18	EF00 00 12	24	EF17 00 06	26
6604 40 00	4	6697 00 01	12	9086 30 13TR	20	CA86 E4 04	18	EF00 00 16	24	EF26 06 01	26
6604 63 00	4	6697 00 02	12	9086 30 17TR	20	CA86 U1 02	16	EF00 00 20	24	EF26 06 02	26
6604 63 40	5	6697 00 03	12	9086 30 21TR	20	CA86 U1 03	16	EF00 02 03	24	EF26 08 02	26
6605 17 13	4	6697 17 00	12	9A86 01 10X099	21, 22	CA86 U1 04	16	EF00 02 04	24	EF26 08 03	26
6605 17 21	4	6697 25 00	12	9A86 01 13X099	21, 22	CA86 U2 02	17	EF00 03 04	24	EF26 10 02	26
6605 25 21	4	6697 40 00	12	9A86 01 70X099	21, 22	CA86 U2 03	17	EF00 04 06	24	EF26 10 03	26
6605 25 27	4	6697 63 00	12	9A86 02 13X099	21, 22	CA86 U2 04	17	EF00 06 08	24	EF26 10 04	26
6605 25 34	4	6698 00 03	11	9A86 02 17X099	21, 22	CA87 A1 02	19	EF00 08 10	24	EF26 13 02	26
6605 40 34	4	6698 01 01	10	9A86 02 21X099	21, 22	CA87 A1 03	19	EF00 10 12	24	EF26 13 03	26
6605 40 42	4	6698 01 02	10	9A86 03 17X099	21, 22	CA87 A1 04	19	EF00 10 16	24	EF26 13 04	26
6605 40 49	4	6698 02 01	10	9A86 03 21X099	21, 22	CA87 E4 02	18	EF00 12 16	24	EF26 16 03	26
6605 63 47	4	6698 02 02	10	9A87 01 10X099	21, 22	CA87 E4 03	18	EF00 12 20	24	EF26 16 04	26
6605 63 48	4	6698 03 01	10	9A87 01 13X099	21, 22	CA87 E4 04	18	EF00 16 20	24		
6606 17 00	4	6698 04 01	10	9A87 01 17X099	21, 22	CA87 U1 02	16	EF02 00 02	24		

Legris SA – Head Office

BP 70411
35704 RENNES cedex 7
tel : +33 2 99 25 55 00
fax: +33 2 99 25 55 99

ARGENTINA

Automacion Micromecanica SAIC

Mariano Moreno 6546 –
1875 Wilde – Bs As
tel: +54 11 4207 6285
fax: +54 11 4206 6281
micro@micro.com.ar

AUSTRALIA

Legris Australasia Pty Ltd

Unit 10
8 Mc Lachlan Avenue
ARTAMON N.S.W. 2064
ACN 073509196
tel: +61 2 94 36 43 00
fax: +61 2 94 39 65 11
australasia@legris.com.au

AUSTRIA

Legris GesmbH

Am Concorde Park 1/E2
2320 SCHWECHAT
tel: +43 1 706 33 34
fax: +43 1 706 33 38
legris.oesterreich@legris.com

BELGIUM + LUXEMBOURG

Legris Belgium S.A

100 rue du Bourdon
BRUXELLES 1180
tel: +32 2 333 09 99
fax: +32 2 332 11 27
legris.be@legris.com

BRAZIL

Legris do Brasil Ltda

Av.Imperador Pedro II, n.1.201
09770 – 420 S.B.C SAO PAULO
tel: +55 11 4332 9200
fax: +55 11 4332 5579
legrisbrasil@legris.com.br

CHINA

Legris Wuxi

Fluid Control Systems Co Ltd
Xing Chuang Road, n°2
Wuxi Singapore Industrial Park
P.R.C 214028 WUXI, JIANGSU
tel: +86 510 528 2625
fax: +86 510 528 2976

CZECH REPUBLIC

Legris SRO

Brnenska 668
664 42 MODRICE
tel/fax: +420 5 4721 6301

DENMARK

Legris Danmark A/S

Klokkestobervej 25A
Postbox 23
9490 PANDRUP
tel: +45 98 204 111
fax: +45 98 204 311

FRANCE

Legris Transair France

74 rue de Paris - BP 70411
35 704 RENNES cedex7
tel: +33 2 99 25 55 00
fax: +33 2 99 25 56 47
transairfrance@legris.com

GERMANY

Legris GmbH

Kurhessenstrasse 15
64546 MORFELDEN WALLDORF
tel: +49 6105 91 0924
fax: +49 6105 91 0913
info-GmbH@legris.com

HOLLAND

Legris BV

Postbus 74, 1380 AB Weesp
Pampuslaan 112
NL – 1382 JR WEESP
tel: +31 29 44 80 209
fax: +31 29 44 80 294
legris.bv@legris.com

ICELAND

Sindra Stal hf.

Borgatuni 31
IS- 121 REYKJAVIK
tel: +354 575 0000
fax: +354 575 0010

INDIA

Legris India PVT Ltd

99, Pace City – I
Sector 37
GURGAON
122 001 HARYANA
tel: +91 1246 372 998
fax: +91 1246 372 997
legris.india@legris.com

ISRAEL

Ilan & Gavish Automation Service Ltd

23 Shenkar Street
49513 – PETAH TIQVA
tel: +972 3 922 1824
fax: +972 3 922 1850

ITALY

Legris SpA

Via Idiomi, 3 / 6
20090 ASSAGO (MI)
tel: +39 02 48 86 13 11
fax: +39 02 48 86 13 11

IVORY COAST

Poly Service Technique

15 BP 450 – ABIDJAN 15
tel: +225 24 75 17
telex: 42 513

JAPAN

NITTO KOHKI CO., LTD

9-4 NAKAIKIGAMI 2-CHOME
OHTA-KU
TOKYO 146
tel: (03) 3755-1111
fax: (03) 3753-2986

MOROCCO

AFIT

6 rue des Batignolles
21700 CASABLANCA
tel: +212 2 24 52 54
fax: +212 2 24 52 54

POLAND

Ara Pneumatik

Ul. Wyscigowa38
53 – 012 WROCLAW
tel: +48 71 364 7282
fax: +48 71 3647 283

PORTUGAL

Legris Lda

Pç. Evaristo da Silva Duarte, 24
Castelo da Maia
4475-634 SANTA MARIA AVIOSO
tel: +351 22982 1922
fax: +351 22982 1924
legris.lda@legris.com

SCANDINAVIA

Legris Scandinavia AB

Smedjevägen 2 B, Box 33
S – 230 53 ALNARP
tel: +46 40 462 490
fax: +46 40 532 120
legris.scandinavia@legris.com

SINGAPORE

Legris SE Asia Pte Ltd

8 Jalan Kilang Timor 01-04
SINGAPOUR 159 305
tel: +65 6271 60 88
fax: +65 6274 99 78

SOUTH AFRICA

Legcon - Demcon Pty Ltd

PO BOX 38621
BOOYENS 2016
tel: +27 11-683-8335
fax: +27 11-683-1080

SPAIN

Legris Cenrasa

Pol. Ind. La Ferreria
C/ de l'Alimentacio, 2 / 4
08110 MONTCADA Y REIXACH
tel: +34 93 575 06 06
fax: +34 93 575 38 07

SWITZERLAND

Legris AG

Rue J; Renferstrasse 9
2504 BIEL
tel: 032 41 344 10 80
fax: 032 41 344 10 70
legris.ch@legris.com

TAIWAN

Legris Taiwan Company Ltd

2F, No. 238 Kao-Kung Road
South District
TAICHUNG
tel: +886 42 263 95 39
fax: + 886 42 263 59 13
legris@legris.com.tw

TURKEY

MERT

Tersane Caddesi 43
KARAKOY ISTANBUL
tel: +90 212 252 84 35
fax: +90 212 245 63 69

UNITED KINGDOM

Legris Limited

1210 Lansdowne Court
Gloucester Business Park, Hucclecote
GLOUCESTER GL3 4AB
tel: +44 (0)1452 623 500
fax: +44 (0)1452 623 501
salesuk@legris.com

UNITED STATES OF AMERICA

Legris Incorporated

7205 E Hampden Ave.
MESA ARIZONA 85208
tel: +1 480 830 7764
fax: +1 480 325-3571
transair@legris-usa.com

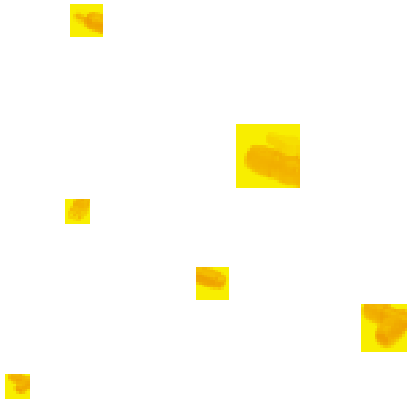

legris transair

www.transair.legris.com

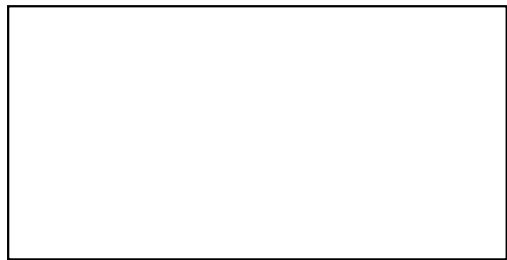



Transair®, advanced air networks
Introduction



Transair[®], Legris air networks

▶▶ Legris S.A. is the world's leading manufacturer of connectors for compressed air distribution systems. Legris S.A. designs, manufactures and sells innovative quick connect solutions (connectors, pipes and tubing) as well as accessories for compressed air, vacuum and low, medium and high pressure fluid power systems. Legris S.A. supplies customers throughout the world and is part of the Legris Industries group of companies.

▶▶ Transair[®] is the division of Legris specialising in air pipework systems for new projects, for renovation, extension or modification of existing systems and for point of use connection. Legris Transair[®] is a rapidly expanding part of the group, incorporating the group's dynamic innovative spirit. We develop solutions that are specifically designed to meet the requirements and constraints of all industrial applications.

▶▶ Transair[®] technology is well known for its high quality and performance and is used in a wide range of industries: aerospace, food, automotive, chemicals, electronics, packaging, vehicle maintenance, clock and watch-making, printing, metal working, pharmaceuticals, plastics, textiles, etc.

Transair[®] meets the requirements of ASME B31.1





legris A DIVISION OF **GRUPE LEGRIS INDUSTRIES**

- ▶▶ 22 sales subsidiaries
- ▶▶ 11 factories and logistic sites
- ▶▶ 1 300 employees



legris
transair

- ▶▶ Over 20,000 systems installed to date, ranging from 15 m to 5,500 m
- ▶▶ The Transair® brand can be found in all 5 continents
- ▶▶ 5 international patents

A technological innovation, as ingenious as it is simple

▶▶ Transair® technology grew from the need to resolve the many problems associated with the distribution and use of compressed air:

- time-consuming and difficult installation
- considerable pressure drops and increasing reduction in the efficiency of the distribution system
- over sized distribution systems with considerable wastage of energy
- problems extending or modifying systems
- pollution of the air by harmful particles
- ugly distribution systems

▶▶ Our design teams therefore strove to introduce improvements to meet 4 criteria:

- it should be simple to install or modify an air distribution system
- the flow rate should be optimised and energy costs reduced
- the technology should be adaptable to meet the most diverse of requirements
- the risks and problems caused by corrosion should be eliminated



▶▶ **Optimising the performance of all machinery and tools connected to the system**

The components and connectors of Transair® distribution systems are designed to be leak-free without obstructing the passage of the air, thus ensuring excellent flow rates and a reduction in both pressure drops and operating costs.

▶▶ **Aluminium pipe to ensure high quality air**

To ensure that the air distributed remains of constant, lasting quality, Transair® pipe is made of aluminium to prevent corrosion.

▶▶ **Quick installation by immediate connection between components**

As industrial production systems must now be able to respond quickly to meet requirements for flexibility and adaptability, one of the main advantages of Transair® technology is that all components can be connected quickly. An air distribution system can, therefore, be assembled, dismantled or modified easily, 7 times faster than a galvanised steel system, without delaying or disrupting production.

▶▶ **A wide range of products and accessories**

Transair®'s wide range of connectors and pipe sizes can meet the most exacting requirements of many sectors of industry:

- maximum flow rate: 3045 m³/h (1790 cfm)
(Ø 63 pipes, 30 m long – operating pressure: 8 bar – pressure drop: 5%)
- maximum operating pressure: 16 bar (ask us for details of the temperature range)
- gases: compressed air, vacuum, inert gases (argon, nitrogen – information for other gases can be provided on request)

Transair®, networking with project teams

- ▶▶ It is not sufficient to invent and produce systems in order to satisfy users of a technology. Transair® has, therefore, always implemented a policy of close collaboration with those involved in installing efficient air distribution systems: design engineers, distributors, installation engineers and users.
- ▶▶ Whether it is a question of providing advice or assistance in designing and dimensioning air distribution systems or co-ordinating the best work skills for installing the systems, Transair® is closely involved and always plays an active role in ensuring that all parties work together.

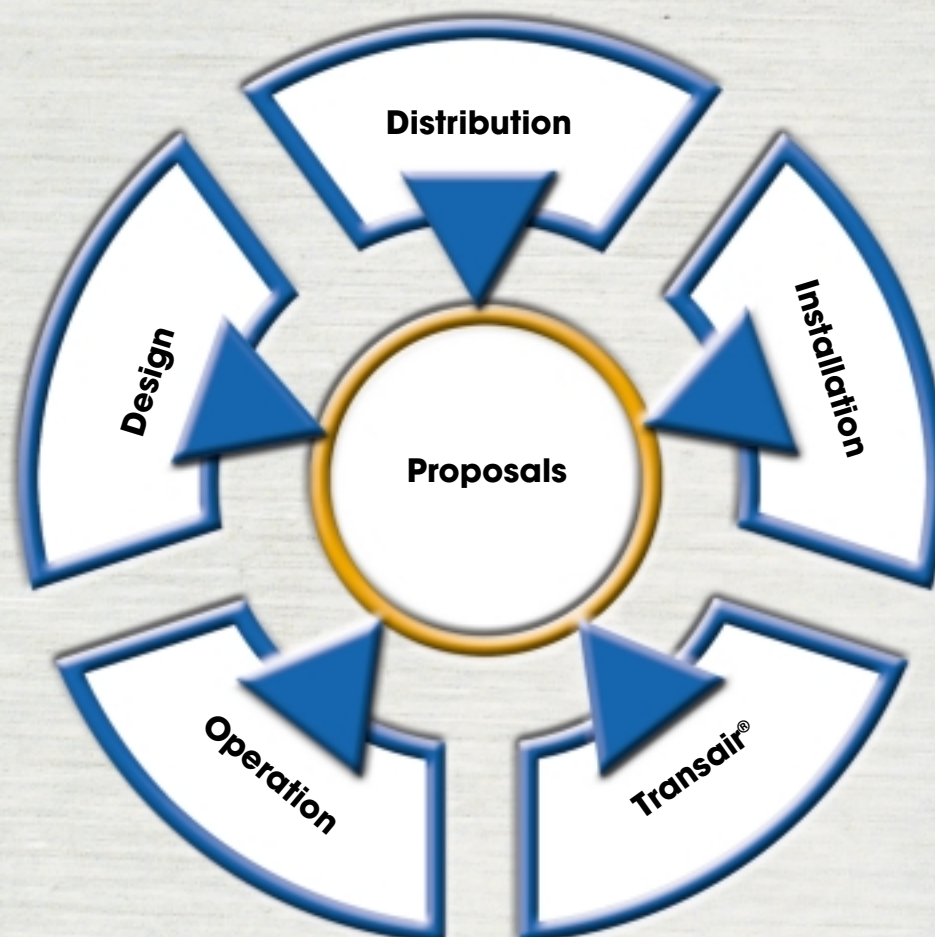

- ▶▶ Preliminary design costing with installation schematic and nominal installation time
- ▶▶ Technical information provided by Transair® experts (standards, regulations, compatibility with other gases, etc)
- ▶▶ Installation training
- ▶▶ Direct delivery to the factory
- ▶▶ Components guaranteed for 10 years
- ▶▶ **This is also part of our "advanced networks" philosophy**

GUARANTEE



Legris S.A. agrees to replace free of charge any Transair® component which does not function due to a manufacturing or material defect, within a period of 10 years from the date of installation.

The present guarantee is valid on condition that :

- Legris S.A. is given reasonable access to examine the products at issue and
- A material or an assembly defect in the fitting or other Transair® component must be clearly and obviously identified.

Excluded from this guarantee which is limited to the cost of product replacement, are defects outside the control of Legris S.A. notably :

- Defects resulting from shocks, vibrations or wear due to contact with any element external to the Transair® installation.
- Defects due to installation not complying with Legris SA's instructions and recommendations.
- Defects due to an installation being used outside the technical limits defined by Legris S.A.
- Defects caused by product modifications not approved in advance by Legris S.A.

Claims under this Guarantee should be addressed in writing simultaneously to the distributor of Transair® products concerned and to Legris S.A., 74,rue de Paris, BP 70411 -35704 Rennes Cedex7 France, and its local subsidiary.....

Site owner.....	
Exact address.....	
Number.....	
Street.....	Town/City.....
Post Code.....	
Country.....	
Building Type :	<input type="checkbox"/> New <input type="checkbox"/> Extension <input type="checkbox"/> Modification
Architects/Design engineers.....	
Distributor.....	
Installer.....	
Date of installation.....	



www.transair.legris.com



legris

transair

Transair®, advanced air pipe systems
76 mm and 100 mm Product Catalogue

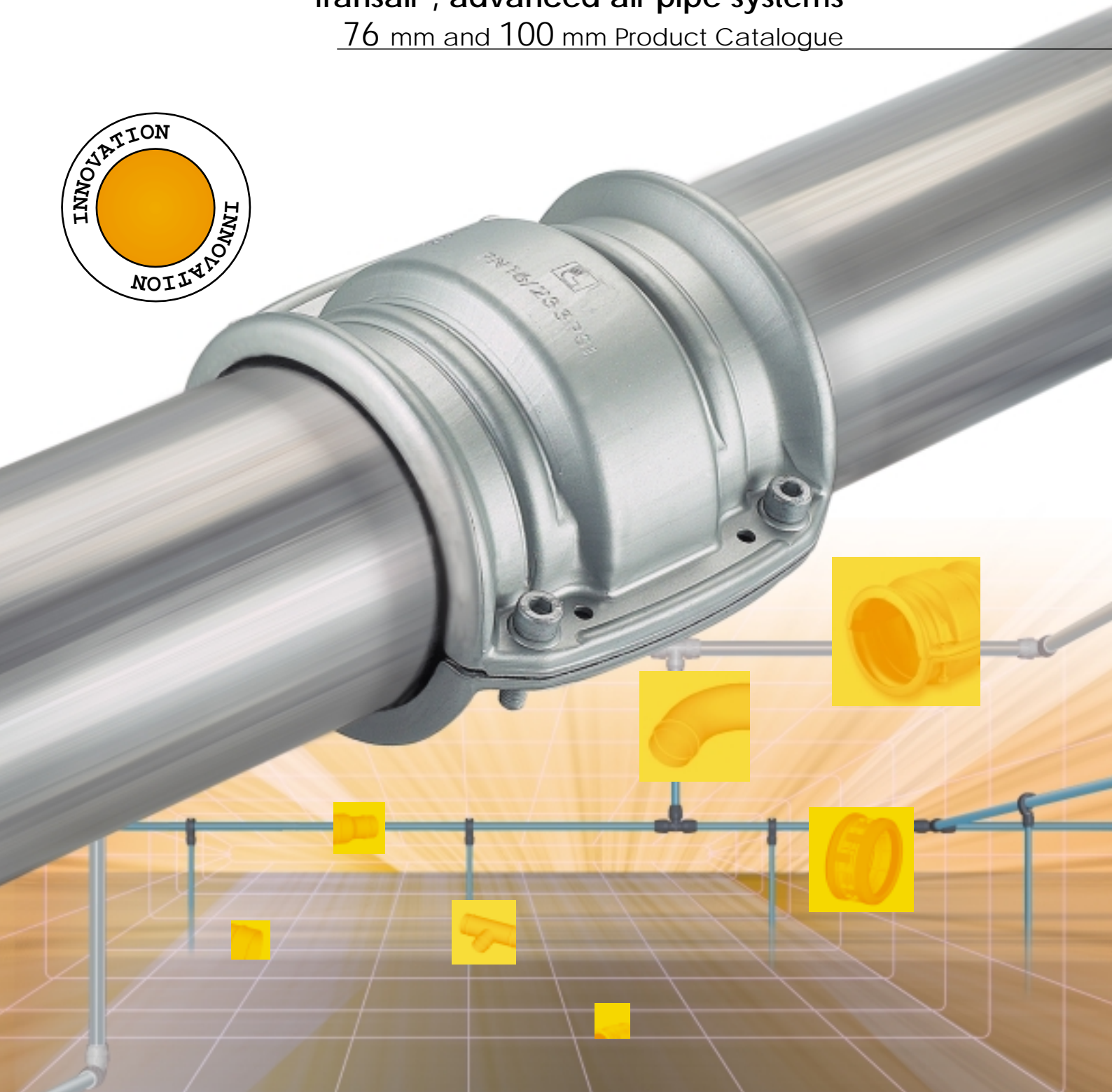
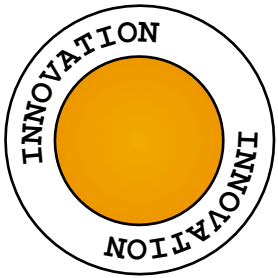

Transair[®], advanced air pipe systems

Transair[®] is an innovative aluminium pipework system for the supply of air, easy to assemble thanks to its rapid connection technology.

With 2 new diameters, 76mm and 100mm, **Transair[®]** helps you still further with your air pipework projects.

Treated steel clamp
» **Reliable connection**

Full passage design
» **High flow**

Stainless steel /
Aluminium pipe
» **Clean air**

Cartridge in engineering
grade plastic
» **Optimum sealing**

Transair® 76 mm and 100 mm technology

The 76 mm and 100 mm **Transair®** system provides the high flow capacity needed in ring mains along with proven advantages that make **Transair®** the leading air pipework system.

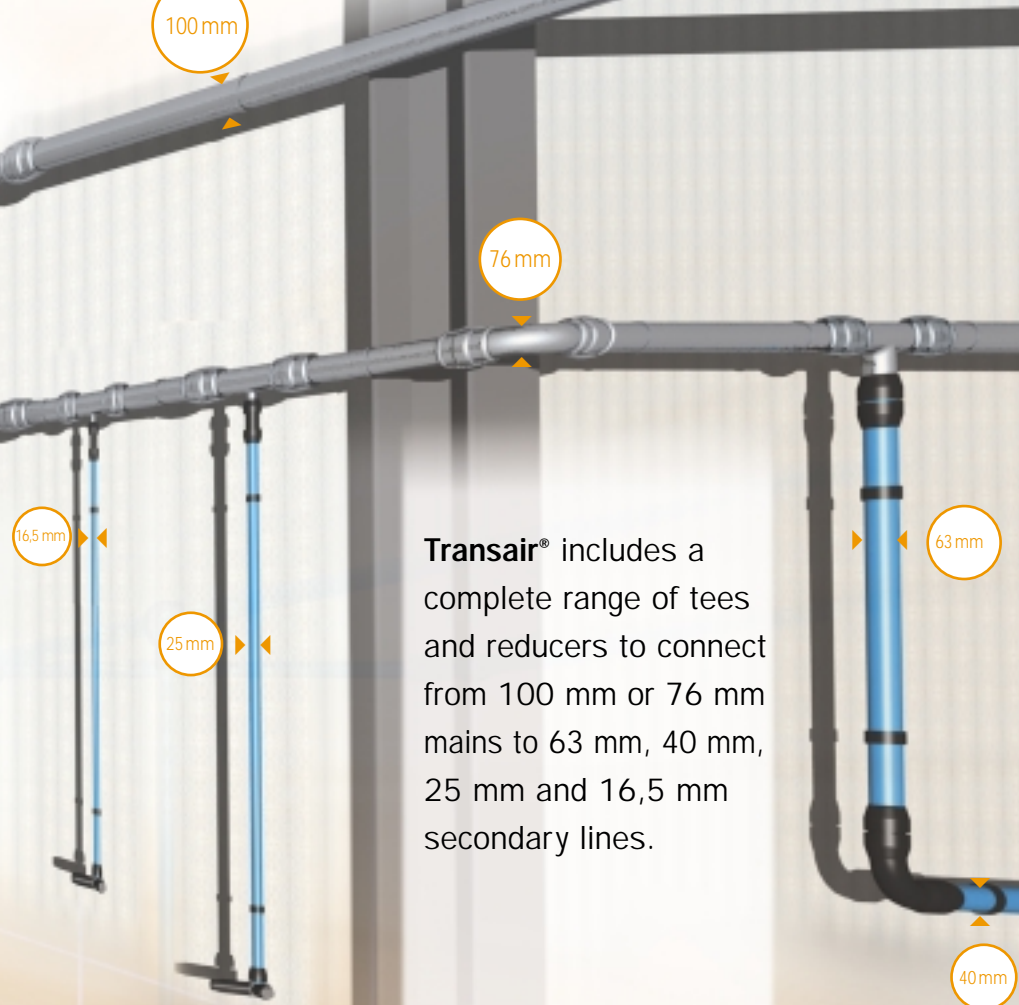

Transair® includes a complete range of tees and reducers to connect from 100 mm or 76 mm mains to 63 mm, 40 mm, 25 mm and 16,5 mm secondary lines.

Transair®, advanced air pipework systems

Performance

Select the **Transair®** diameter for your application based on required flow and pressure drop
(Values are for a ring main pressure of 8 bar, 5% pressure drop – without taking air velocity into account).

Flow			Length									
			164 ft	328 ft	492 ft	984 ft	1640 ft	2460 ft	3280 ft	4265 ft	5249 ft	6561 ft
Nm³/h	NI/min	cfm	50 m	100 m	150 m	300 m	500 m	750 m	1000 m	1300 m	1600 m	2000 m
10	167	6	16,5	16,5	16,5	16,5	16,5	16,5	16,5	25	25	25
30	500	18	16,5	16,5	16,5	25	25	25	25	25	25	25
50	833	29	16,5	25	25	25	25	25	40	40	40	40
70	1167	41	25	25	25	25	40	40	40	40	40	40
100	1667	59	25	25	25	40	40	40	40	40	40	40
150	2500	88	25	25	40	40	40	40	40	40	63	63
250	4167	147	40	40	40	40	40	63	63	63	63	63
350	5833	206	40	40	40	40	63	63	63	63	63	63
500	8333	294	40	40	40	63	63	63	63	63	76	76
750	12500	441	40	63	63	63	63	63	76	76	76	76
1000	16667	589	63	63	63	63	76	76	76	100	100	100
1250	20833	736	63	63	63	63	76	76	100	100	100	100
1500	25000	883	63	63	63	76	76	100	100	100	100	100
1750	29167	1030	63	63	63	76	100	100	100	100	100	100*
2000	33333	1177	63	63	76	76	100	100	100	100	100*	100*
2500	41667	1471	63	76	76	100	100	100	100*	100*	100*	100*
3000	50000	1766	63	76	76	100	100	100*	100*	100*	100*	100*
3500	58333	2060	76	76	100	100	100	100*	100*	100*	100*	100*
4000	66667	2354	76	76	100	100	100*	100*	100*	100*	100*	100*
4500	75000	2649	76	100	100	100	100*	100*	100*	100*	100*	100*
5000	83333	2943	76	100	100	100*	100*	100*	100*	100*	100*	100*
5500	91667	3237	76	100	100	100*	100*	100*	100*	100*	100*	100*
6000	100000	3531	100	100	100	100*	100*	100*	100*	100*	100*	100*

*pressure drop over 5%.

Technical specifications

Suitable fluids :

- Compressed air (dry, wet, lubricated)
- Vacuum
- Inert gas : argon, nitrogen (for other fluids, please consult us)

Max working pressure. :

- 16 bar – please consult us for temperature range
- 13 bar from -20°C to +60°C

Vacuum level :

- 98,7% (13 mbar absolute value)

Working temperature :

- From -20°C to +60°C

Excellent resistance to :

- Compressor oils (mineral or synthetic)
- Ultra-violet rays (for other fluids, please consult us)

Storage temperature

- From -40°C to +80°C









Transair® components are non-flammable, with no propagation of flame.
Materials are 100% recyclable. For silicone free applications : please consult us.

Certification

Transair® conforms to European Standard 97/23 CEE and to ASME B31.1





	6-7	Installation guide
	8-9	Pipe-to-pipe connectors
	10	Rigid pipes and flexible hoses
	11	Accessories
	11	Tools
	12-13	Fixture accessories
	13	Spare parts
	14	Index
	15	Transair® worldwide

Legris has a policy of continual product development and, therefore, reserves the right to modify any products shown in this catalogue, without notification.
All dimensions are indicative.

Installation guide

Pipes are supplied ready for use in standard lengths.

1



3



2

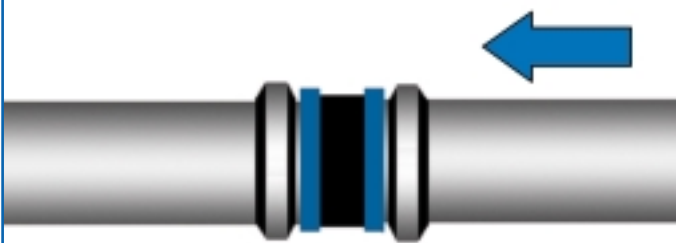

4

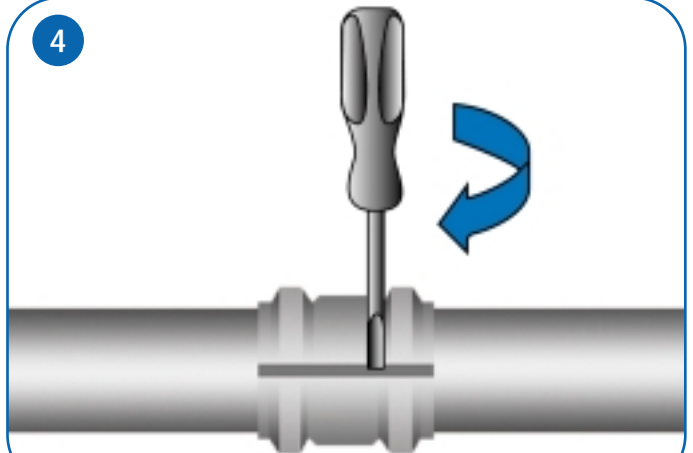

When cutting pipe to length

A – Insert jaws into the portable tool :



B – Form lugs on cut end of the pipe :



Instructions

1 • Areas of application

Before installing **Transair®**, a responsible person should check that the area of installation conforms to regulations designed to prevent the risk of explosion (in particular the risks associated within silo zones) **Transair®** must be installed either after the air receiver or after the dryer. Flexible **Transair®** hose should be fitted at the beginning of the pipe system, in order to counter the vibrations found in any compressed air system. When maintaining or modifying the **Transair®** pipe system the work must be undertaken only after the compressed air system has been vented. The installer must use only **Transair®** components and accessories, and in particular, **Transair®** fixing clips. No other type of fixing method is to be used. The technical characteristics of **Transair®** components as expressed in this catalogue must be respected.

2 • Starting the installed system

Once assembled, the operation of the **Transair®** installation is the responsibility of the installer who, prior to use, must complete all necessary tests. The installer must also ensure that the installation has been properly carried out in line with the instructions and that it meets all legal requirements.

3 • Transair® pipe

Care should be taken to protect pipes against mechanical shocks – especially when close to the passage of fork-lift trucks or where suspended objects are being moved. Equally all excessive rotational movements which could lead to disconnection, whether on the pipes or the supports, must be avoided. **Transair®** rigid pipes must not be bent (formed) or welded. Flexible **Transair®** hose must be used in accordance with the instructions in this catalogue.

4 • Contraction/expansion

The performance of the **Transair®** system is maintained when the effects of expansion or contraction are properly taken into account.

5 • Assembling the components

To ensure proper installation **Transair®** components are supplied with an "Assembly Guide". The installer must follow with care the precise instructions as described in this guide as well as this catalogue

6 • Supports

When suspending from a ceiling **Transair®** clips should be fixed to a rigid support (U channel, cable tray, threaded rod, etc).

This type of support ensures that the clips stay in alignment which allows the pipe to expand and contract.

7 • Observations

When using **Transair®** the following situations must be avoided :

- embedded in a solid mass (concrete, injected foam)
 - fixing other external elements to **Transair®** pipe (other than blowguns, plastic tubes etc with a maximum weight of 200 kgs between 2 clips).
 - the use of **Transair®** as an electric earthing or to support electrical material.
 - the use of **Transair®** with non-compatible components.
- (Please consult us).

ØD	Minimum number of lugs.
76	6
100	7



Pipe-to-pipe connectors

- Optimum sealing
- Reliable connection
- Full passage
- Non-flammable, no propagation of flame (UL94-HB)

- Maximum working pressure :
 - 16 bar : please consult us for temperature range
 - 13 bar from -20°C to + 60°C
- Vacuum level : 98,7% (13 mbar absolute pressure)
- Working temperature : -20°C to + 60°C

RR01 Pipe-to-pipe connector (clamp and cartridge)

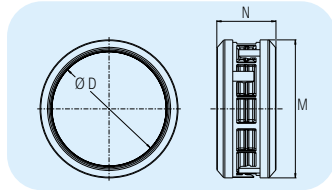
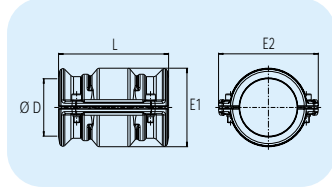

ØD	Transair®	L	E1	E2	M	N	Δ kg Δ
76	RR01 L1 00	146	104	132	98,7	51,4	1,057
100	RR01 L3 00	146	128	157	123	52,7	1,390

Delivered with 4 x M8 captive bolts in treated steel.

RX04 Reducing tee

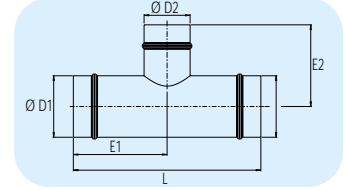
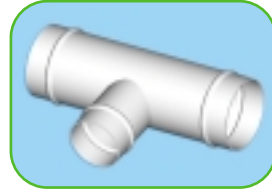

ØD1	ØD2	Transair®	L	E1	E2	Δ kg Δ
100	76	RX04 L3 L1	310	155	135	1,640

RX23 Threaded tee

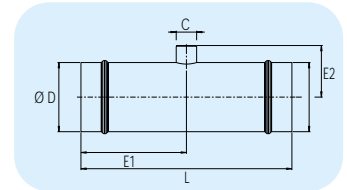
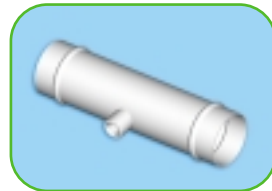

ØD	C	Transair®	L	E1	E2	Δ kg Δ
76	G1/2	RX23 L1 04	290	145	63	0,870
100	G1/2	RX23 L3 04	310	155	75,8	1,540

RX24 Reducing tee

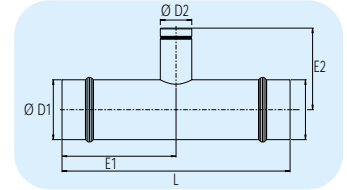
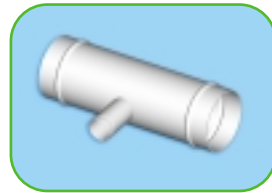

ØD1	ØD2	Transair®	L	E1	E2	Δ kg Δ
76	40	RX24 L1 40	290	145	104	0,910
76	63	RX24 L1 63	290	145	163	1,040
100	40	RX24 L3 40	310	155	116,5	1,570
100	63	RX24 L3 63	310	155	175,8	1,700

RX02 90° elbow

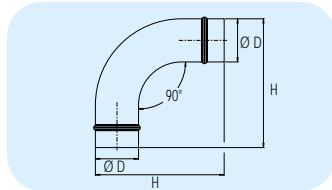

ØD	Transair®	H	Δ kg Δ
76	RX02 L1 00	227	1,000
100	RX02 L3 00	278	1,750

RX04 Equal tee

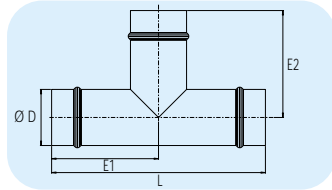
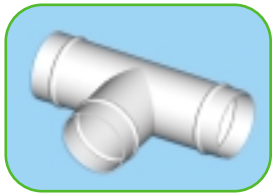

ØD	Transair®	L	E1	E2	Δ kg Δ
76	RX04 L1 00	290	145	145	1,050
100	RX04 L3 00	310	155	135	1,800

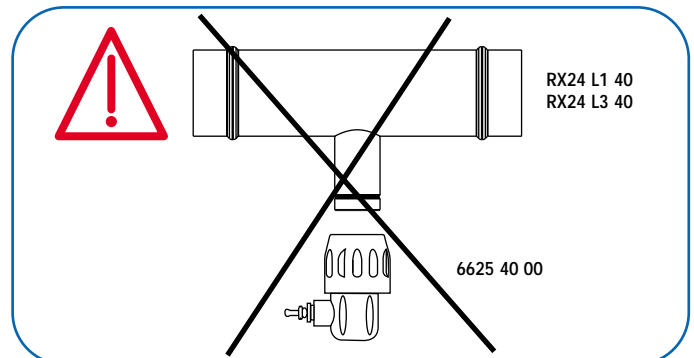

Materials

RR01 : treated steel clamp / engineering grade polymer cartridge / NBR seal.
 RX02 / RX04 / RX23 / RX24 : : stainless steel 304 – material n°1.4301

RX25 End cap

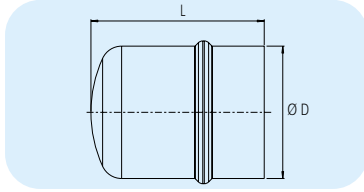

ØD	Transair®	L	ΔkgΔ
76	RX25 L1 00	99,6	0,324
100	RX25 L3 00	107,4	0,532

RX64 In-line reducer

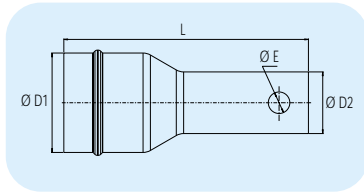
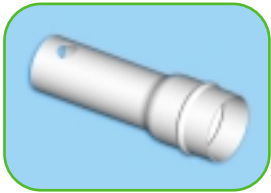

ØD1	ØD2	Transair®	L	ØE	ΔkgΔ
76	63	RX64 L1 63	230	22	0,570
100	63	RX64 L3 63	250	22	0,800

RX66 In-line reducer

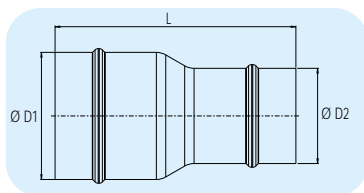
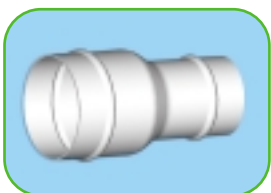

ØD1	ØD2	Transair®	L	ΔkgΔ
100	76	RX66 L3 L1	192,5	0,710



REMINDER

To make a 90° change of direction

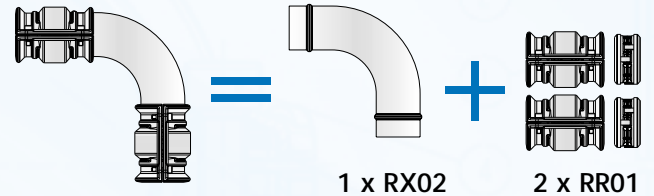

To create a drop

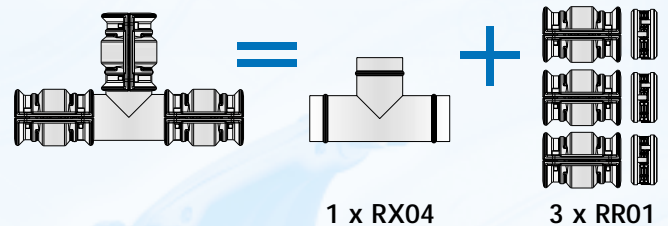

To add an end cap

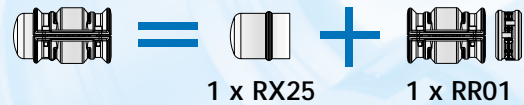

To connect a flange

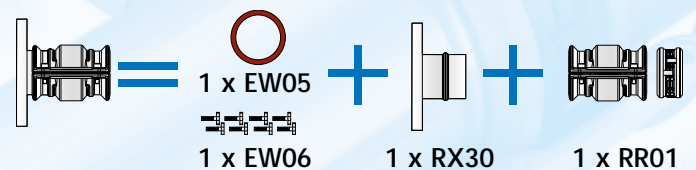

To reduce down from Ø100 to Ø 76

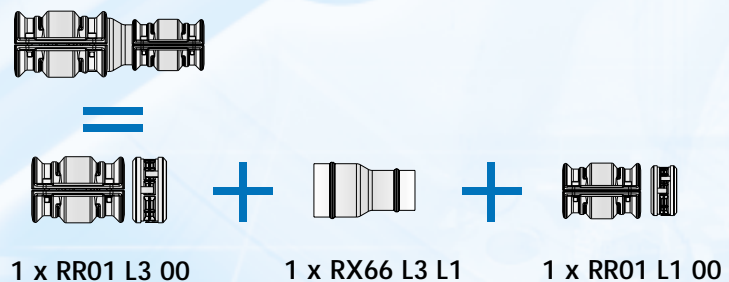

Materials

RX25 / RX64 / RX66 : stainless steel 304 – material n° 1.4301

Rigid pipes & flexible hoses

- Compatible fluids : compressed air, vacuum, argon, nitrogen (for other fluids, please consult us)
- Maximum working pressure. :
 - 16 bar - please consult us for temperature range
 - 13 bar from -20°C to +60°C

- Vacuum level : 98,7% (13 mbar absolute pressure)
- Working temperature : -20°C to +60°C

TX03 3 m stainless steel pipe

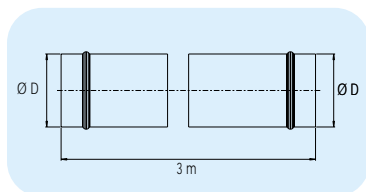

ØD	Transair®	Øext.	Øint.	L (m)	Δ kg Δ
76	TX03 L1 00	76,1	73	3,000	8,857
100	TX03 L3 00	101,6	97,6	3,000	14,800

Please consult us for availability of 76mm and 100mm Transair® in aluminium.

EW07 Self-adhesive stickers for compressed air networks



Transair®
EW07 00 01

TX06 6 m stainless steel pipe

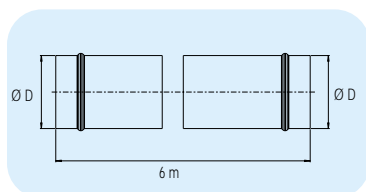

ØD	Transair®	Øext.	Øint.	L (m)	Δ kg Δ
76	TX06 L1 00	76,1	73	6,000	17,714
100	TX06 L3 00	101,6	97,6	6,000	29,600

Please consult us for availability of 76mm and 100mm Transair® in aluminium.

0000 Self-adhesive stickers for vacuum networks

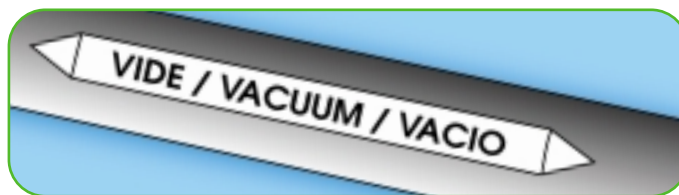

Transair®
0000 01 68

FP01 Flexible hose

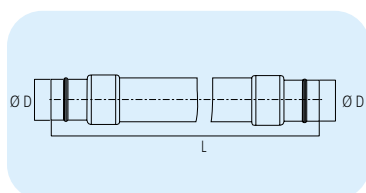

ØD	Transair®	Øext.	Øint.	L (m)	Δ kg Δ
76	FP01 L1 01	91,5	75	1,500	5,150
76	FP01 L1 02	91,5	75	2,000	6,900
100	FP01 L3 02	117,5	100	2,000	12,800
100	FP01 L3 03	117,5	100	3,000	18,360

Min bend radius :
 - Ø76 = 350 mm
 - Ø100 = 500 mm

Materials

Pipe : stainless steel 304 – material n° 1.4301

Flexible hose : • hose and coating : black SBR / NBR • reinforcement : spiral steel wire
 • end fitting : stainless steel 304 – material n°1.4301

Accessories

VR01 Ball valve

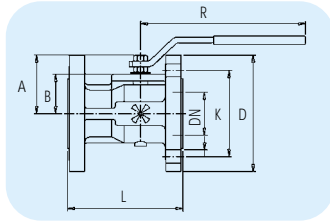

ØD	Transair®	DN	A	B	D	L	K	R	Δ kg Δ
76	VR01 L1 00	65	102	75	185	170	145	320	11,000
100	VR01 L3 00	100	136	104	220	190	180	380	19,700

Delivered with M16 bolts

RX30 Flange

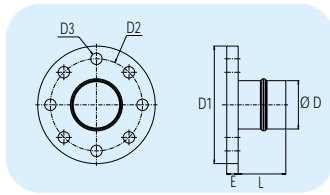

ØD	Transair®	D1	D2	D3	E	L	Δ kg Δ
76	RX30 L1 00	185	145	18	18	75	3,200
100	RX30 L3 00	220	180	18	22	75	5,450

Dimensions conform to EN 1092-1 and ISO 7005

EW05 Flange gasket

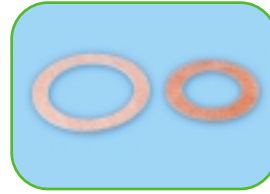

ØD	Transair®	Δ kg Δ
76	EW05 L1 00	0,027
100	EW05 L3 00	0,050

EW06 Flange bolt kit

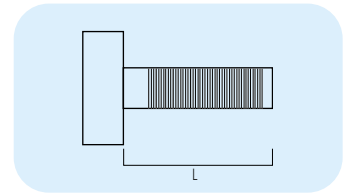

C	Transair®	L	Δ kg Δ
M16	EW06 00 01	60	0,090

Contains 8 bolts and 8 nuts

Materials

Ball valve : treated steel
Flange : stainless steel 304 – material n° 1.4301

Gasket : compressed elastomer fibre
Bolts and Nuts : treated steel

Tools

EW01 Portable tool kit



V	Transair®	Δ kg Δ
220	EW01 00 01	9,500
110	EW01 00 03	9,500

This case contains : 1 portable tool, 1 12 V battery and 1 battery charge.

EW03 12V battery for portable tool



Transair®	Δ kg Δ
EW03 00 01	0,670

EW02 Jaws for portable tool

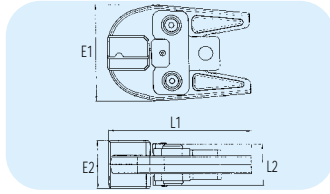

ØD	Transair®	E1	E2	L1	L2	Δ kg Δ
76	EW02 L1 00	103	52	154	46	2,600
100	EW02 L3 00	103	71	154	46	2,800

Fixture accessories

- Can be adapted to all pipework configurations
- For suspension of pipes, from walls, partitions, beams, cable trays, Canalis electrical installations, etc..., vertically and horizontally
- Perfectly suited for use with **Transair®** networks

EX01 Fixing clip for rigid pipe.

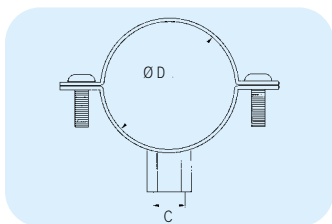

ØD	Transair®	C	Δ kg Δ
76	EX01 L1 00	M8 / M10	0,116
100	EX01 L3 00	M8 / M10	0,134

Transair® fixing clips are designed to bear a maximum weight of 200 kg. However, to ensure good stability of the network, we recommend the use of at least 2 clips per pipe i.e.:

- maximum 1,5 m space between clips for 3 m lengths of pipe.
- maximum 3 m space between clips for 6 m lengths of pipe.

Use only this clip for fixing **Transair®** rigid pipe, all other type of pipe clips are to be avoided. Fix the clip to a rigid support (U-channel, cable tray) to allow for expansion whilst retaining the pipe.

6699 U-channel, 2 metres

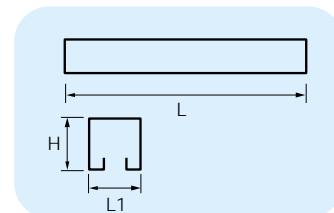
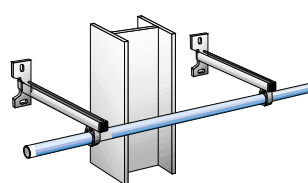
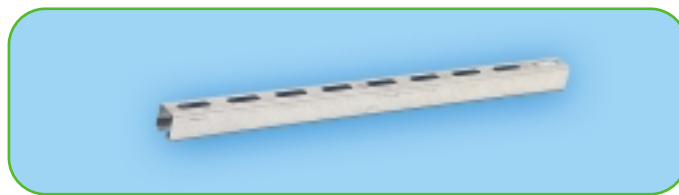

Transair®	H	L (m)	L1	Δ kg Δ
6699 01 01	25	2	25	1,500

6699 Push-on type beam clamp

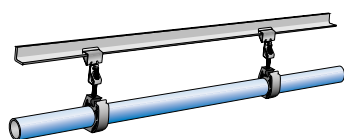
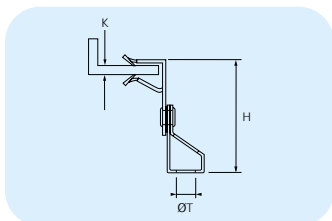

Transair®	H	K	ØT	Max carrying load (kg)	Δ kg Δ
6699 02 05	44	1,5 to 3	M10	68	0,020
6699 02 06	46	3 to 8	M10	68	0,028

6699 U-channel fixing bracket

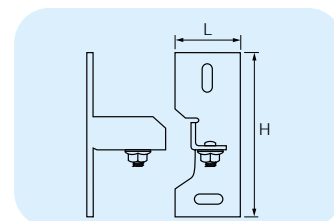
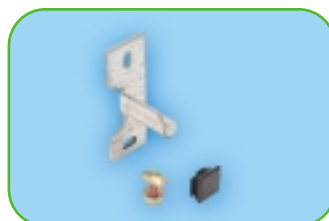

Transair®	H	L	Δ kg Δ
6699 01 02	106	40	0,170

The set comprises :

- 1 bracket
- 1 screw
- 1 nut
- 1 end cap

6699 Screw type beam clamp

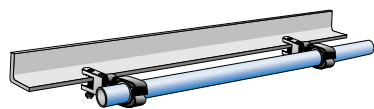
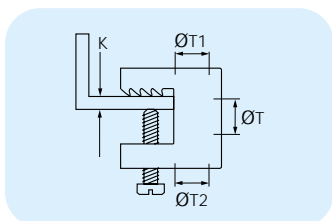

Transair®	ØT2	ØT	ØT1	K	Max carrying load (kg)	Δ kg Δ
6699 03 01	10,7	6,5	10,7	18	45	0,030

6699 U-channel clip fixing set Ø 76 mm - Ø 100 mm

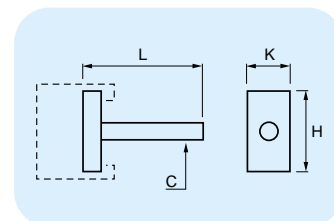

C	Transair®	H	K	L	Δ kg Δ
M10	6699 01 03	35	20	50	0,095

The set comprises :

- 1 channel nut + M10 threaded rod
- 1 washer
- 1 nut

Materials

- **Clip fixing for rigid pipe** : stainless steel 316 - material n° 1.4401
- **Push-on type beam clamp and screw type beam clamp** : galvanised steel

- **Set of fixing accessories** : galvanised steel
- **Clip fixing set Ø 76 mm - Ø 100 mm** : galvanised steel
- **U-channel** : galvanised steel

6699 Fixture on cable tray

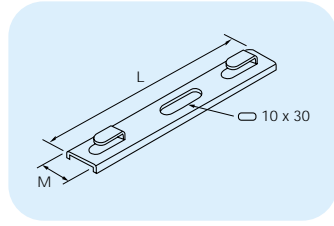
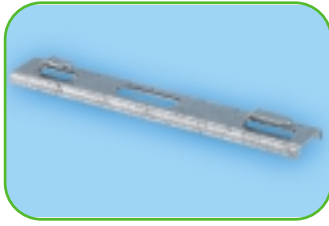

Transair®	L	M	Δ kg Δ
6699 10 03	140	22	0,035

Ø tray rod : 4 to 6 mm

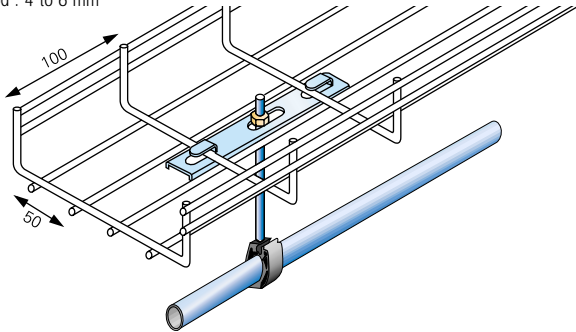

6699 U-channel fixture bracket for RSJ

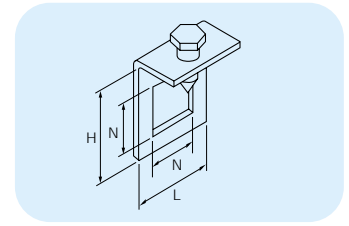

Transair®	H	L	N	Δ kg Δ
6699 03 02	49	41	25	0,080

Supplied with one 8 x 25 needle screw

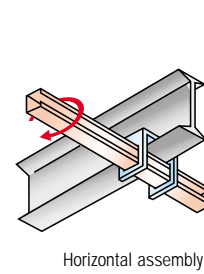
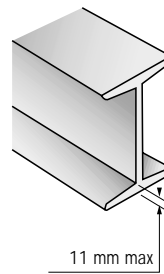

Horizontal assembly

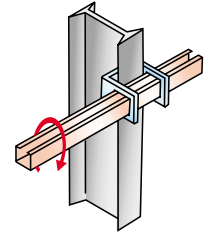

Vertical assembly

Materials

- Fixture on cable tray : galvanised steel
- Fixture on RSJ : galvanised steel and brass screw

Spare parts

RP00 Cartridge

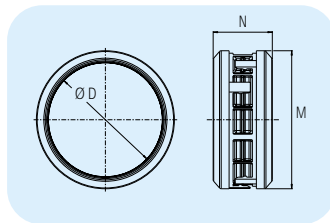

ØD	Transair®	M	N	Δ kg Δ
76	RP00 L1 00	98,7	51,4	0,080
100	RP00 L3 00	123	52,8	0,130

EW04 Bolts for steel clamp RR01

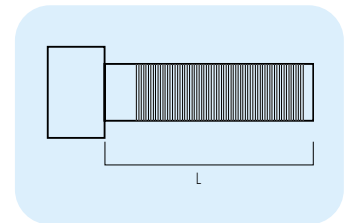

C	Transair®	L
M8	EW04 00 01	30

Materials

- RP00 : : cartridge : engineering grade polymer / NBR seal
- EW04 : treated steel

Index

Part number	Page	Part number	Page	Part number	Page	Part number	Page	Part number	Page	Part number	Page
0000 01 68	10	EW01 00 01	11	EW07 00 01	10	RR01 L1 00	8	RX24 L1 40	8	RX64 L3 63	9
6699 01 01	12	EW01 00 03	11	EX01 L1 00	12	RR01 L3 00	8	RX24 L1 63	8	RX66 L3 L1	9
6699 01 02	12	EW02 L1 00	11	EX01 L3 00	12	RX02 L1 00	8	RX24 L3 40	8	TX03 L1 00	10
6699 01 03	12	EW02 L3 00	11	FP01 L1 01	10	RX02 L3 00	8	RX24 L3 63	8	TX03 L3 00	10
6699 02 05	12	EW03 00 01	11	FP01 L1 02	10	RX04 L1 00	8	RX25 L1 00	9	TX06 L1 00	10
6699 02 06	12	EW04 00 01	13	FP01 L3 02	10	RX04 L3 00	8	RX25 L3 00	9	TX06 L3 00	10
6699 03 01	12	EW05 L1 00	11	FP01 L3 03	10	RX04 L3 L1	8	RX30 L1 00	11	VR01 L1 00	11
6699 03 02	13	EW05 L3 00	11	RP00 L1 00	13	RX23 L1 04	8	RX30 L3 00	11	VR01 L3 00	11
6699 10 03	13	EW06 00 01	11	RP00 L3 00	13	RX23 L3 04	8	RX64 L1 63	9		