

OETIKER



Clamps and Rings



Connecting Technology

OETIKER

Connecting Technology

Clamps and Rings

Contents

| | |
|-------|--|
| 2-3 | OETIKER Worldwide – Connecting Technology |
| 4-5 | OETIKER Clamps and Rings – Product Chart |
| 6-7 | OETIKER Clamps and Rings – System OETIKER |
| 8 | OETIKER Stepless® Ear Clamps 167 |
| 9 | OETIKER Stepless® Low Profile Clamps 168 |
| 10 | OETIKER Stepless® Low Profile Clamps 192 |
| 11 | OETIKER Multi Crimp Rings 150 |
| 12 | OETIKER Clamps ER 194 |
| 13 | OETIKER 1-Ear Clamps with Mechanical Interlock 105&155 |
| 14 | OETIKER Adjustable Clamps 159&163 |
| 15 | OETIKER 1-Ear Clamps 153&154 |
| 16 | OETIKER 2-Ear Clamps 101&151 |
| 17 | OETIKER Twin Clamps 108&158 |
| 18 | OETIKER Stepless® Screw Clamps 178 |
| 19 | OETIKER ALSI Worm Drive Clamps 180 |
| 20 | OETIKER MINI Worm Drive Clamps 180 |
| 21 | OETIKER Worm Drive Clamps A B C 130 |
| 22 | OETIKER Universal Clamps 174 |
| 23 | OETIKER Quick-Connectors 200 |
| 24-26 | OETIKER Installation Tools |
| 27 | OETIKER Installation Instructions |

The OETIKER Group Worldwide

The primary objective of the OETIKER group is to supply OETIKER customers with safe and reliable products.

For over 60 years, OETIKER has revolutionized the clamping of hoses, pipes and other objects with a great variety of clamps and rings for a wide range of materials – all of it complemented by a full range of Quick-Action or Swing Couplings. The OETIKER Group was founded in Switzerland in 1943 and is now a multinational company with a worldwide network of companies, which together offer their customers comprehensive planning, construction, design and service support.

OETIKER companies are strategically placed throughout the world to produce and supply connecting products. Manufacturing is standardized across all OETIKER production companies. OETIKER products are sold both by companies within the OETIKER Group and by a specially selected distributor network.

The OETIKER name is a protected trademark, which stands for quality, innovation and continuous improvement, both literally and in the spirit intended by the founder of the company, Hans Oetiker. Numerous Connecting Technology patents are directly related to the OETIKER name.

OETIKER

Worldwide Connecting Technology

Safe and of the Highest Quality

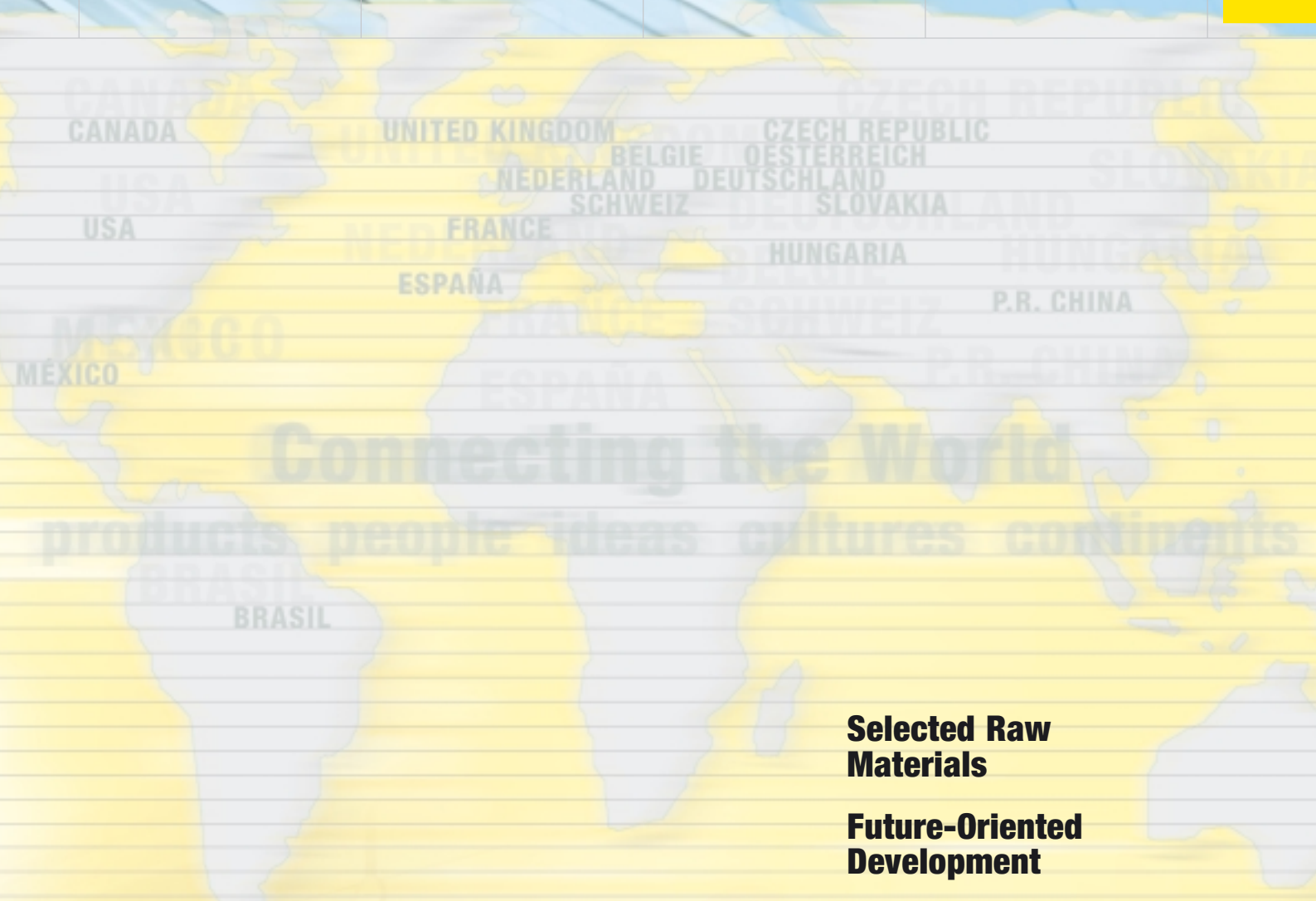

ISO/TS 16949

ISO 9000

ISO 14001

Selected Raw Materials

Future-Oriented Development

Rational Manufacturing Methods

High Quality Standards

OETIKER Quality Standards

All companies within the OETIKER Group have quality certificates according to ISO/TS 16949. OETIKER products are manufactured in OETIKER's own factories. OETIKER companies already comply with the newly formulated environmental guidelines detailed in ISO 14001 which involve the careful use of resources, the use of recyclable materials and minimal use of chemical additives.

In order to ensure optimum quality throughout the world, all OETIKER companies use the latest in production and inspection equipment.



OETIKER Clamps and Rings Product Chart

Safe and Secure

No matter where or what needs to be connected, there is hardly any connection problem which cannot be solved. OETIKER Clamps and Rings can connect practically anything from hoses, pipes, cables, ropes and other objects, in all different materials and under the toughest conditions, securely and permanently – disconnection only as required.

OETIKER solutions for connections in a wide variety of applications and industries prove themselves in use day in and day out:

- Agriculture
- Respiratory Protection
- Building
- Mining
- Chemicals and Petrochemicals
- Electrical and Electronic Industries
- Automotive Supply Industry
- Food and Beverage Industry
- Aerospace Industry
- Medical Industry
- Automotive Industry
- Military
- Rail Industry
- Ship Building
- Welding
- Repair and Maintenance

Application and Selection

Clamp Sealing performance is dependent on:

- Material, hardness, and shape of the parts to be connected
- Geometric formation between the inside diameter of the hose and the part/surface to be connected
- Pressure loads, temperature and environmental influences, type of medium, mechanical stresses (i.e. vibration)
- Correct selection and installation of the clamp

Send your sample parts and all relevant information for your specific application to OETIKER, and we will send you our recommendation for product type, diameter, and method of installation to suit your needs.



150
Multi Crimp Rings
Ø 5.0 - 120.0 mm

Page 11



168
Stepless® Low Profile Clamps
Ø 10.5 - 120.0 mm

Page 9



194
Clamps ER
Ø 4.8 - approx. 25 mm

Page 12



192
Stepless® Low Profile Clamps 192
Ø 28.0 - 120.5 mm

Page 10



167
Stepless® Ear Clamps
Ø 6.5 - 120.5 mm

Page 8



105&155
1-Ear Clamps
with Mechanical Interlock
Ø 10.5 - 116 mm

Page 13

OETIKER Clamps and Rings Product Chart



159&163
Adjustable Clamps
Ø 25.0 - 132.0 mm
Page 14



101&151
2-Ear Clamps
Ø 4.1 - 46.0 mm
Page 16



130
Screw Clamps A B C
Ø 8.0 - 127.0 mm
Page 21



180
ALSI Screw Clamps
Ø 30.0 - 500.0 mm
Page 19



108&158
Twin Clamps
Ø 5.0 - 23.0 mm
Page 17



174
Universal Clamps
Ø ≥35.0 mm / ≥80.0 mm
Page 22



153&154
1-Ear Clamps
Ø 2.9 - 30.7 mm
Page 15



180
MINI Screw Clamps
Ø 6.0 - 219.0 mm
Page 20



178
Stepless® Screw Clamps
Ø 18.0 - 255.0 mm
Page 18



200
Quick-Connectors
DN6 - DN18
Page 23



OETIKER Clamps and Rings System OETIKER

System OETIKER

Besides the multitude of Clamps and Rings developed by Hans Oetiker, a true pioneer in Connecting Technology, OETIKER provides innovative installation concepts with a vision to ensuring safe and efficient system solutions for a multitude of industrial applications.

OETIKER 360° Stepless® Design – The Original

OETIKER Stepless® Clamps have no steps or gaps on their inner circumference. They are designed in such a way that at installation, a metal tongue slips into a corresponding groove. The inside circumference of the clamp fits 360° and stepless onto the hose material and thus gives optimum seal and roundness. This allows very soft and also very inflexible materials to be connected easily. The result is effective clamping of a wide variety of hose materials, of extremely soft and of extremely resistant parts.



167

OETIKER Stepless® Ear Clamps
Optimum radial force distribution is a result of the proven stepless design

In comparison
“Worm-Drive Clamps”



Materials

Only the very highest quality is used in the manufacturing of OETIKER Clamps and Rings. The standard material used for the majority of products is stainless steel. The chromium-nickel content of the stainless steel gives excellent corrosion resistance when exposed to a variety of aggressive environmental influences, both atmospheric and aqueous. The specific mechanical and physical characteristics of these materials guarantee high strength and excellent stability.

OETIKER Clamps and Rings System OETIKER



OETIKER Ear Clamp with Dimple – the Original

The OETIKER System has the ear with a dimple. As the geometry of the closed ear is kept very low, the clamping force is increased and creates a spring effect when the hose material expands or contracts in response to thermal or mechanical influences such as temperature, vibration, etc.

Condition of the Steel Edge

The independent strip processing facilities apply stringent controls to ensure that bandsteel edges are smooth. This greatly reduces the potential for damage to the hose material.

Tolerance Compensation

By closing the clamp ear with a recommended, uniform force – with force priority – component tolerances within the working range of a Stepless® Ear Clamp can be compensated. To achieve this, the ear gap must vary according to the actual size of the parts. For perfect sealing, ear clamps must be closed correctly. For detailed information, please see the Technical Data Sheet for the relevant product group.

Dimensions, Identification and Ordering

OETIKER Clamps and Rings are manufactured to metric dimensions. For identification purposes, the nominal diameter is stamped on each product. For example, “145” stands for an open (nominal) clamp diameter of 14.5 mm.

As a general rule, a nominal diameter should be chosen so that the outside diameter of the elastic hose (when assembled onto the connecting part e.g. hose stem) lies slightly over the middle of the clamping range (see Technical Data Sheet or price lists of OETIKER Clamps and Rings).

Tolerance Compensation

and the ability to influence the radial force by using force-priority installation for Stepless® Ear Clamps



Always quote the 8-digit part number when ordering (see Technical Data Sheet or price lists of OETIKER Clamps and Rings)

For detailed information, please request the Technical Data Sheet for the relevant OETIKER product group.



OETIKER Stepless® Ear Clamps

Product Group **167**



Features

- Narrow band, concentrated seal compression
- 360° Stepless® Design – no steps or gaps on inner circumference
- Specially formed strip edges reduce the risk of damage to the part being clamped
- Lightweight design
- Tampering is visible

The term “Stepless” refers to the absence of steps or gaps on the inner circumference of the clamp. The ingenious stepless design provides uniform compression and a 360° seal.

Standard series Stepless® Ear Clamps are especially well suited to applications involving both flexible and inflexible thin-walled hoses with high “Shore” hardness.

OETIKER Heavy Duty series Stepless® Clamps with particularly high retained loads are especially well suited to applications involving moulded thermoplastics or other less malleable materials with high “Shore” hardness. These are often used in the automotive industry.

Material

- **167** Stainless Steel, Material no. 1.4301 / UNS S30400
- Alternate materials optional

Standard Series

| Size range | Width x Thickness |
|-----------------|-------------------|
| 6.5 - 11.8 mm | 5.0 x 0.5 mm |
| 11.9 - 120.5 mm | 7.0 x 0.6 mm |
| 21.0 - 120.5 mm | 9.0 x 0.6 mm |

Heavy Duty Series

| Size range | Width x Thickness |
|-----------------|-------------------|
| 24.5 - 120.5 mm | 10.0 x 0.8 mm |
| 62.0 - 120.5 mm | 10.0 x 1.0 mm |

Customer-specific sizes available on request.

Installation

See page 27 and Technical Data Sheet.

Application Example

Numerous applications in the vehicle industry, particularly in conjunction with EPDM and silicone hoses

Application Example

Dispensing Equipment

For detailed information, please request the Technical Data Sheet for this OETIKER product group. Send your sample parts and all relevant information for your specific application to OETIKER, and you will receive our recommendation for product type, diameter, and method of installation.

OETIKER Stepless® Low Profile Clamps

Product Group **168**



Features

- Low installed height – minimum space requirement
 - Reusable, can be installed axially or radially
 - Minimal imbalance on rotating parts
 - 360° Stepless® Design – no steps or gaps in inner circumference
 - Specially formed strip edges reduce the risk of damage to the part being clamped
 - Visual check that clamp is closed
- With Type 1 Tolerance Compensation**
- Tolerance-compensation element provides a degree of compensation for the manufacturing tolerances of parts being joined



With Type 1 Tolerance Compensation

OETIKER Stepless® Low Profile Clamps have been specially developed for applications where space or clearance is restricted. They have a low installed height in the closure area, and can be supplied in very small nominal diameter steps. They can be installed axially or radially, and are also reusable – they can be repeatedly opened and reinstalled, e.g. in the vehicle industry for service and maintenance work.

OETIKER Stepless® Low Profile Clamps do not have the same spring properties as OETIKER Ear Clamps. Their sealing performance depends mainly on the forces generated by compressing the elastic material of the part being joined.

Stepless® Low Profile Clamps With Type 1 Tolerance Compensation

OETIKER Stepless® Low Profile Clamps with Type 1 Tolerance Compensation can accommodate small size variations that result from the tolerances of parts being joined. The single, wave/shaped tolerance-compensation element becomes effective when the end of the clamp strip cannot be engaged, because the deviation in the size of the part that is to be clamped is too great.

Material

- **168** Stainless Steel, Material no. 1.4301 / UNS S30400
- Other materials available on request

Size range

10.5 – 19.0 mm

19.5 – 110.0 mm

19.5 – 120.0 mm

25.0 – 120.0 mm

Width x Thickness

9.0 x 0.5 mm

7.0 x 0.6 mm

9.0 x 0.6 mm (with Type 1 Tolerance Compensation)

9.0 x 0.6 mm

Customer-specific sizes available on request.

Installation

See Technical Data Sheet.

For detailed information, please request the Technical Data Sheet for this OETIKER product group. Send your sample parts and all relevant information for your specific application to OETIKER, and you will receive our recommendation for product type, diameter, and method of installation.

Application Example

Drive shafts

Note on ordering:

Low Profile Clamps are, unlike Ear Clamps, marked with the nominal, closed diameter on the clamp strip, e.g. 195 – for a clamp with a closed diameter of 19.5 mm.

Application Example

Protective equipment



OETIKER Stepless® Low Profile Clamps 192

Product Group **192**



OETIKER Stepless® Low Profile Clamps 192, with tolerance compensation features accommodate dimensional variations in the parts being clamped, also when applying high radial forces. In addition, the flexible tolerance-compensation elements, consisting of up to six convolutes in the strip material are designed to allow for minor diameter changes caused by temperature variations and/or the effects of vibration.

Besides rotating applications, OETIKER Stepless® Low Profile Clamps 192 are suitable for securing the dust covers on shock absorbers, cooling and heating systems, air-springing systems, etc. The Product Group 192 is customised for specific applications and is produced with small diameter graduations. They are installed using special OETIKER tooling to ensure optimum connections in numerous industrial applications.

Note on ordering:
Low Profile Clamps 192 are identified with the nominal closed diameter, e.g. 69.5 – for a closed diameter of 69.5 mm.

Material
– **192** Stainless Steel, Material no. 1.4301 / UNS S30400

| Size range | Width x Thickness | Tol. Element |
|-----------------|-------------------|--------------|
| 28.0 - 120.5 mm | 10.0 x 0.8 mm | 3-times |
| 34.0 - 120.5 mm | 10.0 x 0.8 mm | 6-times |

Installation
See Technical Data Sheet.

For detailed information, please request the Technical Data Sheet for this OETIKER product group. Send your sample parts and all relevant information for your specific application to OETIKER, and you will receive our recommendation for product type, diameter, and method of installation.

Features

- Tolerance-compensation convolutes allow for variations in component tolerances
- Designed to allow for minor diameter changes caused by temperature variations and/or the effects of vibrations
- 360° Stepless® Design – no steps or overlaps in inner circumference
- Low installed height – minimum space requirement
- Minimal imbalance on rotating parts
- Specially formed strip edges reduce the risk of damage to the part being clamped
- Simple, safe installation

Application Example
Cooling system connections



Application Example
Drive shafts



OETIKER Multi Crimp Rings

Product Group **150**



Features

- Constant, uniform, circumferential compression
- Aluminium model – lightweight
- Low Profile-corresponding to gauge of material
- No imbalance on rotating parts
- Specially formed strip edges reduce the risk of damage to the part being clamped
- Made to customer specifications if required
- Suitable for use as pre-assembled clamp connection
- Special shrinking device available on request

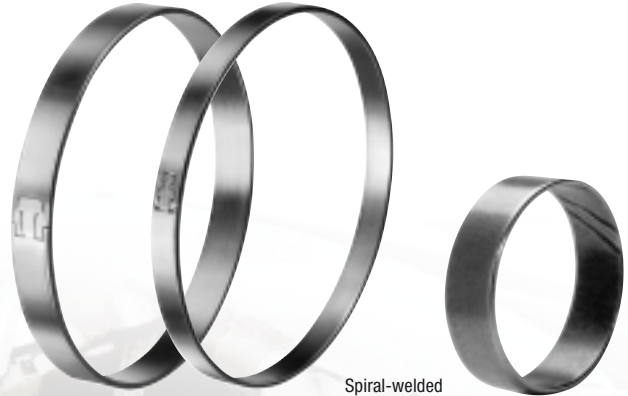

Spiral-welded

OETIKER Multi Crimp Rings are made from band steel, have a T-lock and their low profile makes them particularly suitable for large rotating parts, as they have no protruding parts to obstruct the space surrounding the hose.

OETIKER Multi Crimp Rings must only be closed using tooling, which has been specially developed for this purpose. The design of this tooling allows several Multi Crimp Rings to be closed simultaneously.

As well as their application for use on rotating components and airbag systems, OETIKER Multi Crimp Rings are suitable for fixing boots on steering gears, shock absorbers, coolant systems and ventilation systems as the profile of these rings is only limited by their material thickness.

Application Example

Cooling system connections

Material

- 150 Stainless Steel, Material no. 1.4301 / UNS S30400
- Option: aluminium, Material no. 3.3535

Size range

5.0 - 120.0 mm

Customer-specific sizes available on request.

Installation

See Technical Data Sheet.

Application Example

Drive shafts



Spiral-welded

In diameters ≤ 50 mm, OETIKER Multi Crimp Rings are available manufactured from spiral-welded stainless steel tube. Ideal for industrial applications, vehicles and medical equipment.

For detailed information, please request the Technical Data Sheet for this OETIKER product group. Send your sample parts and all relevant information for your specific application to OETIKER, and you will receive our recommendation for product type, diameter, and method of installation.

OETIKER Clamps ER

Product Group **194**



The Clamp ER is an innovative and economical high-quality clamp for low-pressure applications on materials that are slightly compressible. It has been developed for a very wide range of applications in industry, vehicles and medical equipment.

As a result of their low installed height, OETIKER Clamps ER require minimal space. Their low weight and quick and simple installation makes them the optimum method of connection for numerous industrial applications.

Available in very small diameter steps, and in customer and application specific versions, they can be closed with special OETIKER Installation Tools.

Note on ordering:

OETIKER Clamps ER are marked with the nominal, closed diameter on the clamp strip, e.g. 6 – for a clamp with a closed diameter of 6.0 mm.

Material

– 194 Stainless Steel, Material no. 1.4310 / UNS S30100

Size range *Width x Thickness*
4.8 - approx. 25 mm 6.5 x 0.25 mm

To test this product for suitability and selection of the right diameter, please send us the relevant sample parts and comprehensive information about the application.

Installation

See Technical Data Sheet.

For detailed information, please request the Technical Data Sheet for this OETIKER product group. Send your sample parts and all relevant information for your specific application to OETIKER, and you will receive our recommendation for product type, diameter, and method of installation.

Features

- Innovative, economical, high-quality clamp
- Miniature sizes, from 4.8 mm diameter
- Safe connections for low-pressure applications
- Low installed height – minimal space requirement
- Lightweight
- Specially formed strip edges reduce the risk of damage to the part being clamped
- Simple, safe installation



Application Example
Medical equipment

Application Example
Vehicle industry –
turbocharger systems

OETIKER 1-Ear Clamp with Mechanical Interlock

Product Group **105 & 155**



Features

- Narrow band – 7mm
- Lightweight
- Specially formed strip edges reduce the risk of damage to the part being clamped
- Mechanical interlock allows use of pre-coated materials
- Tampering is visible
- Fast and simple to install



Economical quality clamp for low-pressure applications. Developed for a variety of applications in the automotive industry, general industry and for applications involving synthetic tubing.

The mechanical interlock also eliminates the need for spot welding at the joint, which would then make it vulnerable to corrosion.

Material

- **105** Galvanized or zinc-plated steelband
- **155** Stainless Steel, Material no. 1.4301 / UNS S30400

| <i>Size range</i> | <i>Width x Thickness</i> |
|-------------------|--------------------------|
| 10.5 - 116 mm | 7.0 x 0.6 / 0.75 mm |

Customer-specific sizes available on request.

Installation

See page 27 and Technical Data Sheet.

Application Example
Dispensing Equipment

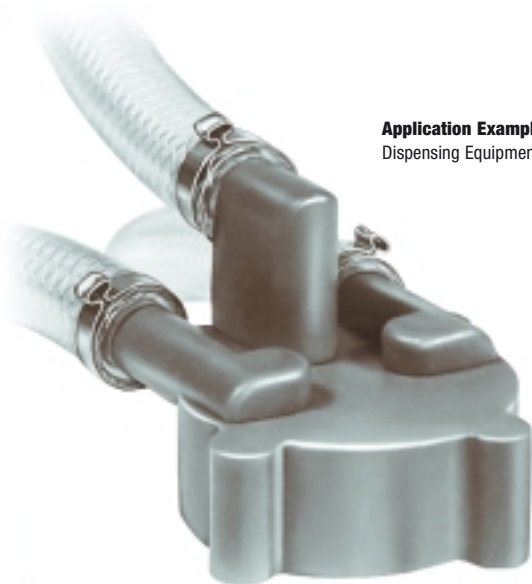

Application Example
Irrigation systems



For detailed information, please request the Technical Data Sheet for this OETIKER product group. Send your sample parts and all relevant information for your specific application to OETIKER, and you will receive our recommendation for product type, diameter, and method of installation.

OETIKER Adjustable Clamps

Product Group **159 & 163**

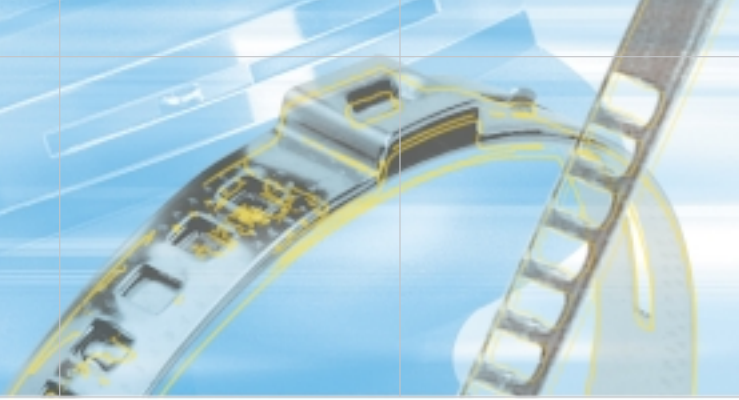

PG 159 – Adjustable Clamps

PG 163 – Adjustable Clamps with Radial Guiding

OETIKER Adjustable Clamps with Radial Guiding are suitable for numerous industrial applications.

Their special closure technology makes the diameter of these clamps adjustable, so that one clamp covers a relatively large clamping range.

During the closure process, there is optimum radial guidance for the inner strip. At the same time, the overlapping below the ear prevents the material of the hose being caught. This results in effective, powerful all-round sealing.

To meet particular diameter requirements, the pre-selected engagement window position of the Adjustable Clamp with Radial Guiding can be customer or application specific.

Using OETIKER Adjustable Clamps, a wider clamping range can be covered by having a larger number of engagement positions. Both variants of the OETIKER Adjustable Clamp are particularly suitable for securing Neoprene CVJ boots on drive shafts and steering boxes. For CVJ boots made of thermoplastic material, OETIKER Stepless® Ear Clamps – Heavy Duty Range should be used.

Material

– **159 & 163** Stainless Steel, Material no. 1.4301 / UNS S30400

Adjustable Clamps

| Size range | Width x Thickness |
|-----------------|-------------------|
| 25.0 - 50.0 mm | 7.0 x 0.8 mm* |
| 40.0 - 110.0 mm | 7.0 x 0.8 mm* |

Adjustable Clamps with Radial Guiding

| | |
|-----------------|--------------|
| 30.0 - 116.0 mm | 7.0 x 0.6 mm |
| 72.0 - 132.0 mm | 9.0 x 0.6 mm |

*Diameter range covered by a single clamp

Installation

See page 27. Further installation instructions available on request.

For detailed information, please request the Technical Data Sheet for this OETIKER product group. Send your sample parts and all relevant information for your specific application to OETIKER, and you will receive our recommendation for product type, diameter, and method of installation.

Features

- Clamps can be adjusted to several nominal diameters
- Suitable for securing Neoprene gaiters or other soft materials
- Inner ring with radial guidance for effective and powerful all-round sealing
- Clamp suitable for many different applications
- Specially formed strip edges reduce the risk of damage to the part being clamped
- Simple, quick axial or radial installation

Application Example
After-market alternative
for drive shafts



Application Example
Flexible attachment of
additional components

OETIKER 1-Ear Clamps

Product Group **153 & 154**



Features

- Fast, simple and safe installation
- Specially deburred edges reduce the risk of damage to the part being clamped
- Tampering is visible

With Insert

- For small diameters from 2.9 mm
- Curled insert bridges the gap below the clamp ear and thus provides an effective all-round seal



With Insert

1-Ear Clamps

OETIKER 1-Ear Clamps are commonly used where a minimal protrusion and a small clamping range is essential.

They are well suited for Original Equipment Manufacturing (OEM) and Maintenance Repair and Overhaul (MRO). They are also suitable for use with rubber hoses, plastic tubing, electrical cables, welding hoses and other materials.

Material

– **153** Stainless Steel, Material no. 1.4301 / UNS S30400

Size range

3.3 - 30.7 mm

Installation

See page 27 and Technical Data Sheet.

Application Example

Food and Beverage industry

1-Ear Clamps with Insert

OETIKER 1-Ear Clamps with Insert are ideal for demanding hose or tubing clamping applications involving soft or hard rubber or plastic materials. The insert bridges the gap below the clamp ear and its curled edge prevents cutting or other damage to the hose.

The thin insert has an oval outward dimple which is positioned precisely under the clamp ear, effectively preventing material from being lifted into the ear gap during clamp closure, something which often happens with soft hose material. This double dimple combination in both insert and clamp creates a strong all-round effective compression seal.

This type of clamp is especially suited for use in the automotive industry, medical technology and with electrical and electronic components.

Material

– **154** Clamp:

Stainless Steel, Material no. 1.4301 / UNS S30400

Insert:

Stainless Steel, Material no. 1.4310 / UNS S30100

Size range

2.9 - 30.0 mm

Installation

See page 27 and Technical Data Sheet.

The OETIKER System has the ear with a dimple. As the geometry of the closed ear is kept very low, clamping force is increased and creates a spring effect when the hose material expands or contracts in response to thermal or mechanical influences such as temperature, vibration, etc.

For detailed information, please request the Technical Data Sheet for this OETIKER product group. Send your sample parts and all relevant information for your specific application to OETIKER, and you will receive our recommendation for product type, diameter, and method of installation.

Original size



OETIKER 2-Ear Clamps

Product Group **101 & 151**



The first "Original" OETIKER Ear Clamp.

This Hans Oetiker design was the first of its kind when it came onto the market in 1951 and since then, it has revolutionized connection technology throughout the world. To this day, it has remained a best seller.

OETIKER 1-Ear Clamps are well suited for Original Equipment Manufacturing (OEM) and Maintenance Repair and Overhaul (MRO). They are also suitable for use with rubber hoses, plastic tubing, electrical cables, welding hoses and other materials.

The 2-Ear Clamps, in comparison to the 1-Ear Clamps, have a larger clamping range. Due to the specific geometry of the closed ear, clamping force is increased and creates a spring effect when the hose material expands or contract in response to thermal or mechanical influences such as temperature, vibration, etc.

Material

- **101** Zinc-plated Steel, Material no. 1.0338 / SAE 1008/1010
- **151** Stainless Steel, Material no. 1.4301 / UNS S30400

Size range

4.1 - 46.0 mm

Narrow version available on request.

Installation

See page 27 and Technical Data Sheet.

For detailed information, please request the Technical Data Sheet for this OETIKER product group. Send your sample parts and all relevant information for your specific application to OETIKER, and you will receive our recommendation for product type, diameter, and method of installation.

Features

- Tamper-proof durable seal due to robust construction
- For air and fluid media lines
- 2-Ear version for extended clamping version
- Specially deburred edges reduce the risk of damage to the part being clamped
- Tampering is visible
- Fast and simple installation



Original size

Application Example
Workshop needs



Application Example
Strain-relief in the electrical industry

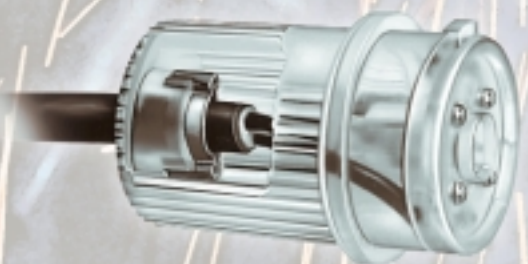

OETIKER Twin Clamps

Product Group **108 & 158**



Features

- Parallel alignment of twin hose lines, cables, pipes, rods, tubing or rope connections
- Parallel alignment of unequal diameters and/or at different centre distances.
- Specially deburred edges reduce the risk of damage to the part being clamped
- Robust construction
- Fast and simple installation

OETIKER Twin Clamps are available in open and closed versions. Both styles are strong alignment clamps designed to withstand the ruggedness of typical industrial environments.

The closed clamp is mainly intended for industrial applications, i.e. for the parallel alignment of welding hoses. The open clamp is suitable for fastening pipes, cables and hoses i.e. the automotive industry.

Both styles are suitable for use as pre-assembled clips.

Twin Clamps – Open Version

OETIKER Open Twin Clamps are made from steel strip

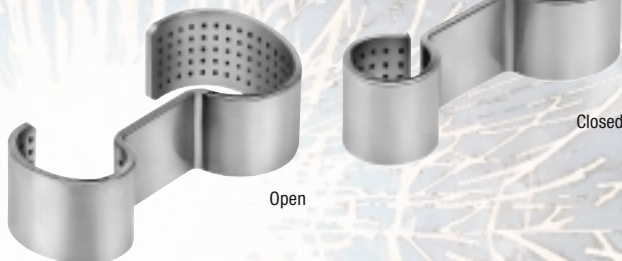

Material

– **158** Stainless Steel, Material no. 1.4301 / UNS S30400

Installation

The open Twin Clamps are installed by wrapping them around parallel lines after they have been positioned to the desired location, preferably by pushing them along axially. The two sides of the clamp are then depressed individually, or, if the two sides of the clamp have different diameters, pressed together in a custom designed tool. For details see the Technical Data Sheet.

Twin Clamps – Closed Version

OETIKER closed twin clamps are made as a complete unit, shaped from one piece of cut tube



Material

- **108** Zinc-plated Steel, Material no. 1.0338 / SAE 1008/1010
- Optional Stainless Steel, Material no. 1.4301 / UNS S30400

Size range

5.0 - 23.0 mm

Installation

The closed twin clamps are placed in an axial direction over the objects, which are to be held parallel. They are then depressed slightly in the middle using OETIKER pincers so that the clamp can no longer be moved laterally.

For details see the Technical Data Sheet.

Application Example

Parallel installation of hoses, tubes etc.

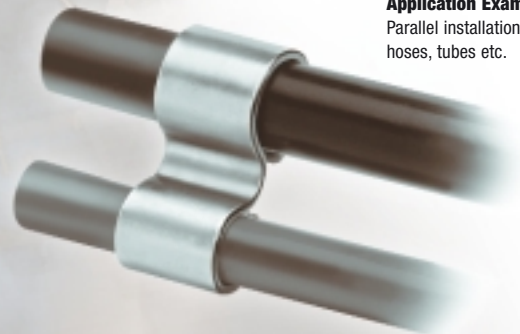

For detailed information, please request the Technical Data Sheet for this OETIKER product group. Send your sample parts and all relevant information for your specific application to OETIKER, and you will receive our recommendation for product type, diameter, and method of installation.

OETIKER Stepless® Screw Clamps

Product Group **178**



Self-tensioning

Features

- 360° Stepless® Design – no steps or gaps on inner circumference
- Specially formed strip edges reduce the risk of damage to the part being clamped
- Reusable
- Multiple diameter settings
- Conforms to SAE J1508 Type SSPC

Self-tensioning

- Self-tensioning spring reacts to thermal cycle diameter changes to maintain a strong, uniform seal
- Conforms to: SAE J1508 Type SSPC, TMC RP332 Type SSPC

Stepless® Screw Clamps

OETIKER Stepless® Screw Clamps are designed for extremely demanding applications where reusability and the assurance of a leak-free seal is not compromised while tightening. This unique design draws the clamp band evenly around the circumference of the hose.

The narrowness of OETIKER constant tension clamps compared to other clamps of this type, together with a low installation torque, combine to produce a strong, uniform seal with the hose.

Already proven to seal medical grade tubing, thin-walled and/or hard synthetic material, etc, this style can also be custom made for individual applications.

Stepless® Screw Clamps Self-Tensioning

OETIKER Stepless® Self-Tensioning Screw Clamps have been developed specifically for motor-vehicle cooling systems (petrol / gasoline and diesel engines), particularly for use in conjunction with EPDM and silicone rubber hoses. They prevent coolant leakage, which may occur when clamped parts cool after the engine has been turned off. The diameters of components such as hoses, hose stems, etc. become smaller, and this is the only type of clamp, which has been designed to compensate for that reduction and prevent leaks.

Material

- 178 Steel strip, sleeve, Retaining segments (D-nuts):
Stainless Steel, Material no. 1.4301 / UNS S30400
- Screw:
Stainless Steel, Material no. 1.4319 / UNS S30200
- Spring:
17-7PH (aerospace quality)

| | |
|-------------------|--------------------------|
| <i>Size range</i> | <i>Width x Thickness</i> |
| 18.0 - 255.0 mm | 9.0 x 0.6 mm |

Installation

See Technical Data Sheet.

For detailed information, please request the Technical Data Sheet for this OETIKER product group. Send your sample parts and all relevant information for your specific application to OETIKER, and you will receive our recommendation for product type, diameter, and method of installation.

Application Example

Cooling system connections

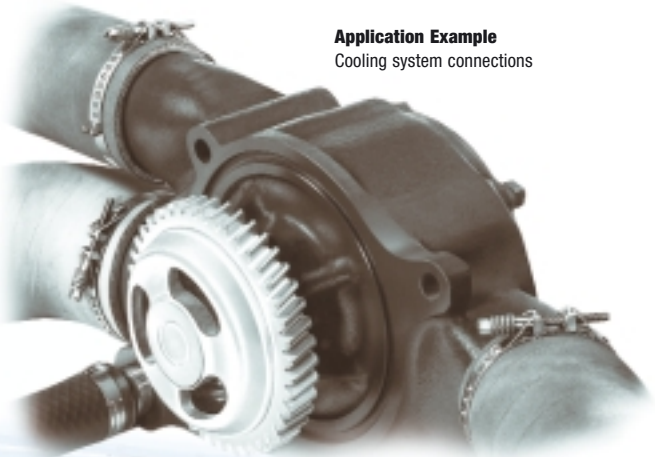

The term "Stepless®" refers to the absence of steps or gaps on the inner circumference of the clamp. The ingenious stepless design provides uniform compression and a 360° seal.

Application Example

Numerous applications in the vehicle industry, particularly in conjunction with EPDM and silicone hoses

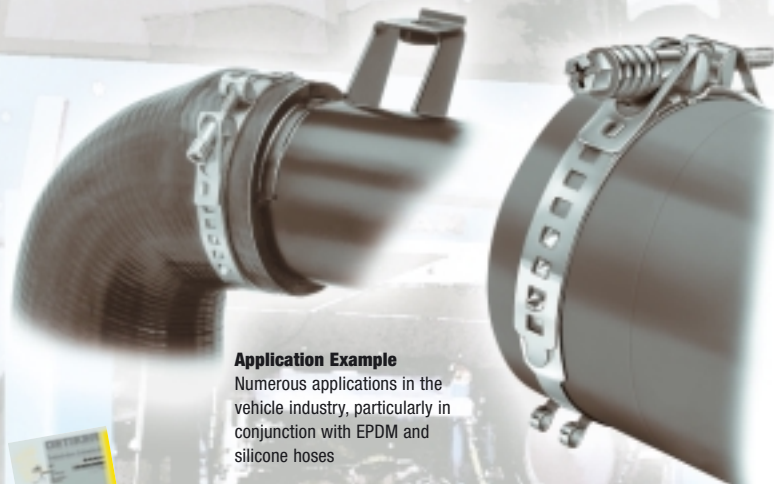

OETIKER ALSI Worm Drive Clamps

Product Group **180**



Features

- Toggle lock for simple, timesaving installation
- Toggle has intermediate position to prevent unintended opening
- Visual indication to protect against overloading
- Higher tightening torque than required by DIN 3017
- Screw with 5 A/F socket for safe installation

Version with wing screw

- Alternative with wing screw – a tool integrated in the clamp



Version with wing screw

ALSI Universal Worm Drive Clamps

Using strip supplied in 10, 20, or 30 metre rolls and the correct fastener, you can make a clamp for any diameter above 50 mm.



OETIKER ALSI Worm Drive Clamps with toggle lock, intermediate position, and visual overload protection are suitable for a multitude of applications. i.e. telecommunications equipment, mounting signs and notices, in construction, in horticulture and farming, in ship and boat building, for general workshop use, etc. The toggle fastener ensures simple, timesaving installation, even under difficult conditions.

ALSI Clamps are based on DIN 3017, but they will withstand tightening torques up to 10 Nm. On the standard version, tensioning is carried out using a 5 A/F DIN 911 hexagon key. For especially quick and easy installation, the ALSI F version is available with a wing screw.

The specially shaped wings of the screw ensure a good grip for fast assembly and dismantling without the need for a separate tool.

Material

- **180 W4** Strip and fastener:
Stainless Steel, Material no. 1.4301 / UNS S30400
- Screw:
Stainless Steel, Material no. 1.4305 / UNS S30300

Size range *Width x Thickness*

30.0 - 500.0 mm 12.2 x 0.9 mm

Customer-specific sizes up to 1000 mm diameter available on request.

Installation

Installation instructions available on request.

Two-Piece ALSI Worm Drive Clamps

Two-Piece ALSI Worm Drive Clamps are used to assemble applications, which do not have their own fasteners, e.g. the pipe ends of stainless steel chimneys.

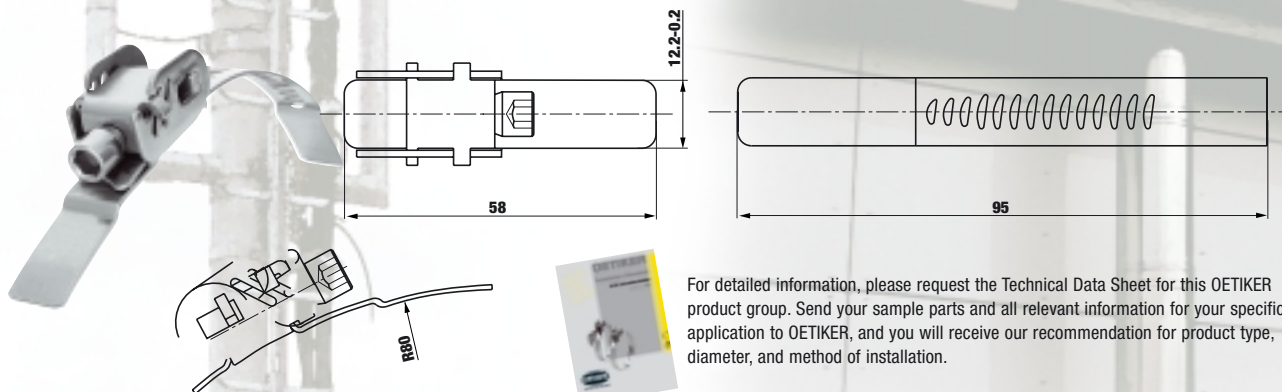

For detailed information, please request the Technical Data Sheet for this OETIKER product group. Send your sample parts and all relevant information for your specific application to OETIKER, and you will receive our recommendation for product type, diameter, and method of installation.

OETIKER MINI Worm Drive Clamps

Product Group **180**



MINI R+S Worm Drive Clamps

MINI R+S Worm Drive Clamps with embossed perforations are resistant to rust and acids, and based on DIN 3017. Their non-magnetic properties and minimal space requirements make them especially suitable for securing magnetic sensors, particularly on pneumatic cylinders.

Material

– **180** W4 Strip and fastener:

Stainless Steel, Material no. 1.4301 / UNS S30400

Screw:

Stainless Steel, Material no. 1.4305 / UNS S30300

| Size range | Width x Thickness |
|----------------|-------------------|
| 7.0 - 219.0 mm | 5.0 x 0.4 mm |

Installation

Installation instructions available on request.



Typ R+S
with integrated wing, preassembled

The OETIKER MINI R+S Worm Drive Clamp, with wing integrated into the fastener, is especially suitable for laboratories, hobbies and other applications that demand simple, fast assembly and dismantling. The torsionally stiff wing with special embossed pattern ensures a good grip.

For detailed information, please request the Technical Data Sheet for this OETIKER product group. Send your sample parts and all relevant information for your specific application to OETIKER, and you will receive our recommendation for product type, diameter, and method of installation.

Features

- Embossed clamp strip – not perforated
- Compact design – minimal space requirement
- Reusable
- Cylindrical screw head with screwdriver slot
- Fast, simple and safe installation
- Type R+S is resistant to rust and acids and non-magnetic
- Alternative with wing screw – a tool integrated in the clamp

MINI R Worm Drive Clamps

MINI R Worm Drive Clamps with embossed perforations are used, for example, in automobile manufacturing to connect fuel lines and, because of their open design, are easy to install on pre-assembled hoses.

Material

– **180** W2 Strip:

Rust-resistant Chromium Steel, Material no. 1.4016 / UNS S43000

Screw and body:

Steel, zinc-plated, chromated blue

| Size range | Width x Thickness |
|---------------|-------------------|
| 6.0 - 19.0 mm | 5.0 x 0.4 mm |

Installation

Installation instructions available on request.



Typ R
Can be supplied open or closed



OETIKER Worm Drive Clamps A B C

Product Group **130**



Features

- Highly flexible screw clamp with numerous applications
- Reusable
- Hexagon-head screw with slot for screwdriver
- Fast, simple and safe installation
- Screw Clamps B and C as toggle clamps for simple operation
- Screw Clamp C is alternative with wing screw – a tool integrated in the clamp

Worm Drive Clamp A

Highly flexible Worm Drive Clamp made from perforated strip with high tensile strength. Closed body with hardened precision screw (2 mm pitch). Precise, circular support at the closure.

Condition at time of delivery

Strip closed, screw set to largest diameter.

Material

- **130** Strip and body:
Rust-resistant Chromium Steel, Material no. 1.4016 / UNS S43000
- Screw:
Steel, zinc-plated and chromated blue

| Size range | Width x Thickness of strip |
|---------------|----------------------------|
| 8.0 - 82.0 mm | 8.0 x 0.7 mm |

Installation

Installation instructions available on request.

Application Example

Extraction equipment



OETIKER Worm Drive Clamps A, B and C are suitable for a multitude of applications, for example, in automobile manufacturing, in construction, in horticulture and farming, in ship and boat building, for general workshop use, etc.

Worm Drive Clamps B and C

These precision Worm Drive Clamps have a toggle closure for easier handling. Strip clamp made of perforated high-tensile material, with hardened precision screw (2 mm pitch on Type B and 3 mm for Type C).

Condition at time of delivery

Rolled up but not screwed on.

Material

- **130** Strip and body:
Rust-resistant Chromium Steel, Material no. 1.4016 / UNS S43000
- Screw:
Steel, zinc-plated and chromated blue

| Size range | Width x Thickness of strip |
|-----------------|----------------------------|
| 9.0 - 127.0 mm | 8.0 x 0.7 mm (Clamp B)* |
| 14.0 - 127.0 mm | 12.0 x 0.7 mm (Clamp C)* |

* Further diameters available on request

Installation

Installation instructions available on request.

For detailed information, please request the Technical Data Sheet for this OETIKER product group. Send your sample parts and all relevant information for your specific application to OETIKER, and you will receive our recommendation for product type, diameter, and method of installation.

OETIKER Universal Clamps

Product Group **174**



Features

- Separate locks (screw or ratchet) with perforated band steel
- Universally applicable at various diameters and widths
- Supplied in kit format, bulk, or to customer specification
- With ratchet lock, installation and removal is possible without tools
- Reusable

The combination of OETIKER ratchet or screw locks with perforated stainless steel band strip is part of the OETIKER Universal Clamp Program, and can be used for diameters greater than 35 mm.

The versatility of OETIKER Universal Clamps are second to none as they can be used as an alternative to most OETIKER Clamps, in maintenance, repair, and aftermarket purposes.

When the ratchet lock is employed, the clamp can even be installed and removed without tools.

Universal clamps are suitable for unpressurized retaining functions, e.g. for filters, dust bags, or induction hoses.

Material

– **174** All parts are Stainless Steel,
Material no. 1.4301 / UNS S30400

| Size range | Width x Thickness |
|------------|-------------------|
| ≥ 35.0 mm | 10.0 x 0.5 mm |
| ≥ 80.0 mm | 18.0 x 0.8 mm* |

Installation

Installation instructions available on request.

* For use with 18 mm screw lock



Screw Lock 18 mm

Screw Lock 10 mm

For detailed information, please request the Technical Data Sheet for this OETIKER product group. Send your sample parts and all relevant information for your specific application to OETIKER, and you will receive our recommendation for product type, diameter, and method of installation.

OETIKER Quick-Connectors

Product Group **200**



Features

- Innovative connection solution
- Compact design through optimised use of material
- Can be installed and removed many times
- Optimised cross-section for maximum flow
- Tube end can be utilised as a connecting element
- Plug/tube is free to rotate
- Cracking pressure up to 1100 bar
- Fast, simple and safe installation
- Customer-specific tool for removal

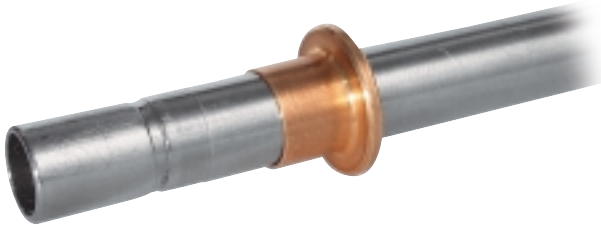

Removal sleeve loose on grooved tube



Customer-specific tool for removal

Application Example

Quick-Connector as supply connection for oil or cooling-water lines

OETIKER Quick-Connectors are a new system for the fast, safe connection of fluid supply lines. They can be developed for specific applications and supplied in different versions to suit customers' requirements. Because they can be fitted without tools, OETIKER Quick-Connectors are the optimal connector for numerous industrial applications. OETIKER Quick-Connectors drastically reduce installation times.

OETIKER Quick-Connectors are suitable for applications that make severe demands – whether as a connection element for safety-relevant components, or for installation on air conditioners, oil coolers, brake lines, turbo-units, etc.

Material

– **200** Body:

Material no. 1.0737 / UNS G12144

Circlip:

Material no. 1.4310 / UNS S30100

Seal:

NBR

Other materials and seal variants available on request.

Size range

DN6 - DN18

Connection / Disconnection

To make the connection, push the grooved tube into the Quick-Connector until it engages.

To disconnect, push the disconnection sleeve/tool into the Quick-Connector to the stop, hold it in this position, and pull out the tube.

For detailed technical information, see Technical Data Sheet.

For detailed information, please request the Technical Data Sheet for this OETIKER product group. Send your sample parts and all relevant information for your specific application to OETIKER, and you will receive our recommendation for product type, diameter, and method of installation.

OETIKER Installation Tools

Manual or pneumatic OETIKER Pincers for the safe and correct installation of Clamps

OETIKER Clamps and Rings should be installed with the tools developed for them. They ensure correct installation and optimum product performance. When electronically-controlled tools are used, the closure process can be continuously monitored.

Manual Pincers



Pincer for Ear Clamps
Standard Jaw



Pincer for Ear Clamps
Side Jaw



Pincer for Ear Clamps
Narrow Jaw



Pincer for
Stepless Ear Clamps
– Heavy-Duty range

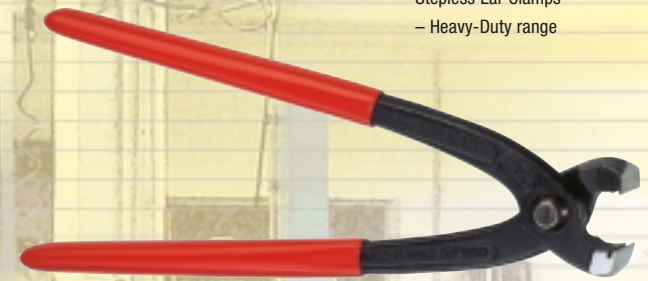

Pincer for
Stepless® Low Profile Clamps 192



Pincer with return spring for
Stepless® Low Profile Clamps



Pincer with return spring for
ER Clamps



Flexible screwdriver

For further information, please see the OETIKER Tool Catalogue.

OETIKER Installation Tools



Pneumatic Power Tools

Pneumatic Pincers

OETIKER recommends the use of pneumatic pincers with an electronic gauge to ensure correct and uniform closure, especially for high-volume production.



OETIKER Electronically Controlled Pneumatic Power Tool ELK 01

The OETIKER ELK 01 is an innovative tool that guarantees reliable installation. It has electronic monitoring of all closure parameters and excludes the possibility of unnoticed faulty closures. It consists of a pincer and a control unit, which combined, make up a complete closure system. Using "Clamp Process Monitoring" software, closure data can be stored on a PC connected to the OETIKER ELK 01.

Quantified, qualified, and verified closure of clamps using the new Electronically-Controlled Pneumatic Pincer OETIKER ELK 01.

For further information, please see the OETIKER Tool Catalogue.

OETIKER Installation Tools

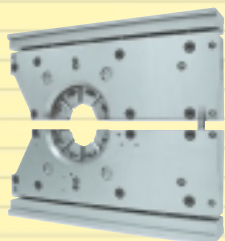

OETIKER COMPACT – a portable, separable Installation Tool for Multi Crimp Rings

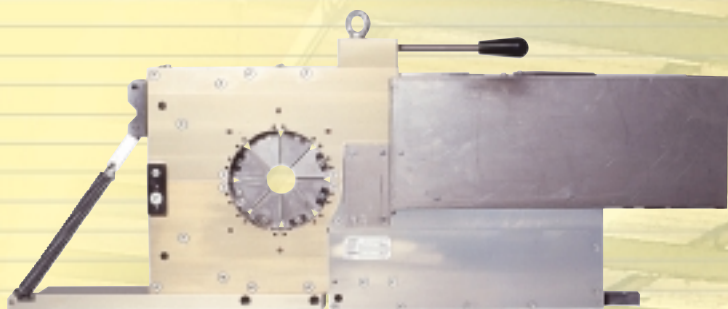

OETIKER FLEX – a Hydraulic and Pneumatic Installation Tool for Multi Crimp Rings

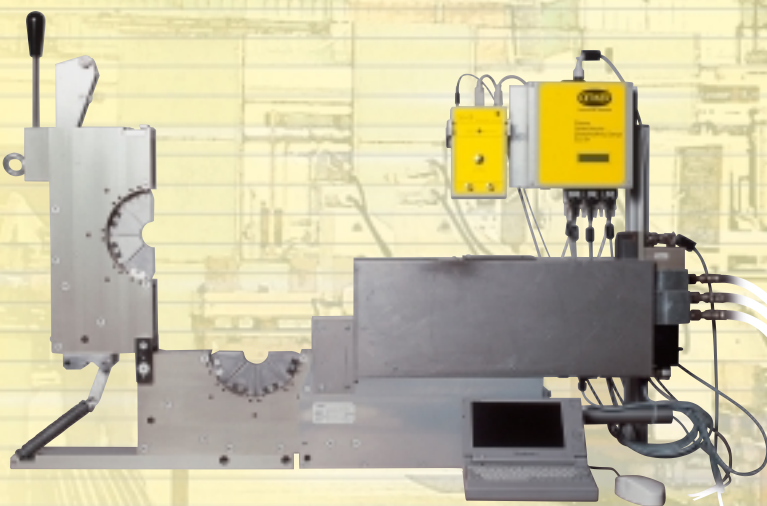

The **OETIKER ELS 01** is an Electronically Controlled Hydraulic Swaging Tool that guarantees the reliable installation of Multi Crimp Rings with electronic monitoring of all closure parameters

Installation Tool for Multi Crimp Rings

OETIKER Multi Crimp Rings should be installed using the Swaging Tools developed for them – their compact design enables the simultaneous installation of several Multi Crimp Rings.

For installing Multi Crimp Rings, OETIKER offers a range of Closing Tools:

- A portable, separable Installation Tool, OETIKER COMPACT
- A hydraulic and Pneumatic Swaging Tool, OETIKER FLEX
- An Electronically Controlled, Hydraulic Swaging Tool, OETIKER ELS 01.

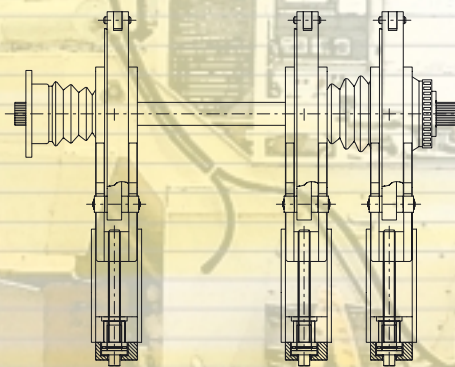

An example of an arrangement of Swaging Tools – all 3 closures can be carried out simultaneously

For further information, please see the OETIKER Tool Catalogue.

OETIKER Installation Instructions



Installation Instructions for Ear Clamps

Installation Examples

Position a properly-sized ear clamp on the hose fitted with a hose stem. Close clamp ear fully.



Using standard jaw pincer for Ear Clamps



When space is restricted, use a side jaw pincers and hold it parallel to the hose during closure



Using an OETIKER Pneumatic Pincer



To remove a clamp, place the pincer jaws across the ear and cut through it

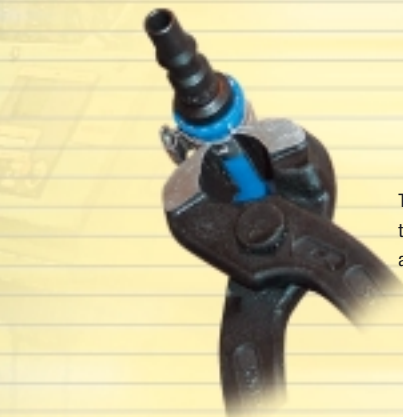

To remove a Stepless Ear Clamp, grasp the strip end with the pincer and pull it away

The careful selection and installation of OETIKER clamps is of the utmost importance for their performance in a specific application. This brief description is intended only as an initial guide to the most important points. For detailed information on selection and installation, please see the technical data sheet for the relevant product group.

OETIKER will be happy to help you to make the right choice for your specific application, If you provide us with the relevant application samples and as much information as possible about your application, we can recommend the best product type, diameter and installation to suit your needs.

Installation

Only OETIKER recommended tools should be used to close OETIKER clamp ears, and they should be closed with a uniform, recommended force. The closing force must be the parameter that determines when closure is complete. This method ensures positive stress on the hose which does not result in excessive compression or expansion of the band material. The visible deformation of the clamp ear provides a visible and instant check that closure has been carried out.

Please note that, unless otherwise stated, OETIKER Clamps and Rings can be used only once. Once removed, they can no longer be reused and should be discarded.

Radial and axial installation of Clamps

Individual variants of the closure geometry of Stepless® Ear Clamps enable larger diameters to be opened so that they can be installed radially. This enables them to be used on parts which are already installed or assembled – i.e. for repair and maintenance work.

