

Rubber Fab Technologies Group's

# SMART GASKET<sup>®</sup>

Improved Pharmaceutical  
In Line Systems Validation

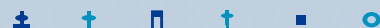
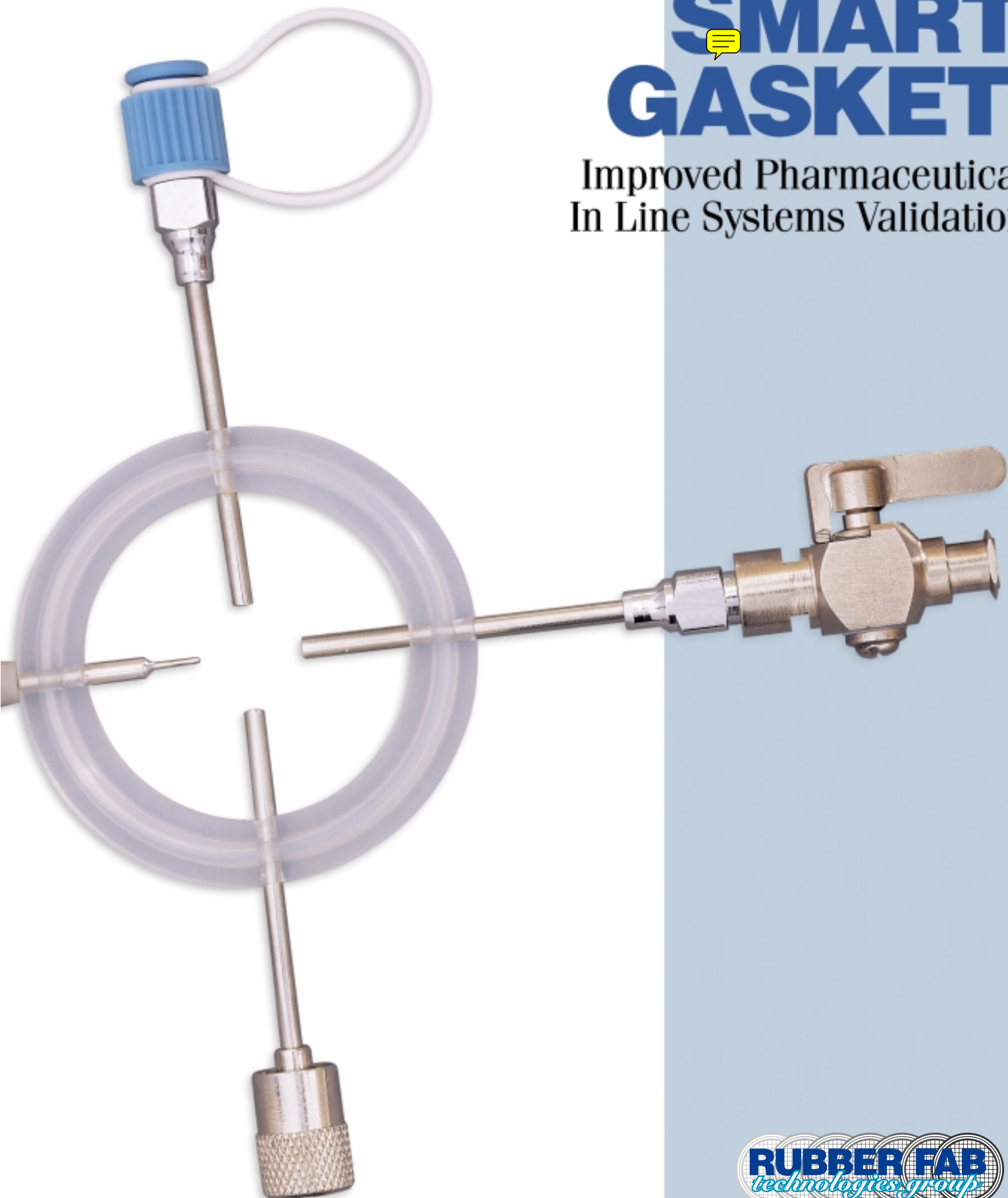

## Our Commitment is Certified

Rubber Fab Technologies Group successfully meets the goals and standards set forth by the U.S. Pharmacopeia, Class VI certification, passes cytotoxicity criteria and complies with Title 21 CFR 177.2600 standards. Our certification is an endorsement of our commitment to provide you with quality products that meet the highest sanitary standards and purity criteria.

NAMSA, a world leader in testing services for the medical device industry, has certified our PTFE, fluoroelastomers, platinum silicone and EPDM hygienic seals. You can be assured of our continuous commitment to our superior quality.

### Meets High Pharmaceutical Standards

- U.S. Pharmacopeia Class VI Certification
- Cytotoxicity Criteria
- CFR Title 21 Section 177.2600
- Traceability: Lot and Batch
- Certification: Lot and Batch
- ASME-BPE Standards
- USDA Standards
- 3-A Sanitary Standards
- Current Good Manufacturing Practices (CGMP)
- Animal Derived Ingredient Free
- Metal Detectable Elastomers available

© Smart Gasket and ADI Free are registered trademarks of Rubber Fab Technologies Group.

Rubber Fab Technologies Group's Metal Detectable products are patent pending.



## Smart Gasket®

Rubber Fab's Smart Gasket's value is proven when validating sterility in a high-purity pharmaceutical system. Your standard sanitary flange utilizing the Smart Gasket is used to obtain the critical thermal mapping information you need during the validation process.

Smart Gasket easily installs between two sanitary standard flanges using the Rubber Fab sanitary Smart Clamp to secure the flanges. Our clamp provides up to four internal ports for accepting the Smart Gasket thermocouple samples or accessories; i.e. ACC-T or K-199-S-Short Temperature Probe; ACC-L or K-199A-L-Long Temperature Probe.

Choose between Rubber Fab's Thermocouple hygienic seal or select the Smart Gasket Spore Trap to securely retain spore challenge test strips. There is also a sampler device available that utilizes standard luer lock fittings.

Meter fluids in your process system utilizing a peristaltic pump or withdraw samples utilizing our luer lock sampler and luer lock valve or syringe.

### Smart Gasket Benefits:

- Use temporarily or permanently without custom thermowells or expensive custom fittings.
- Easy to expand to multiple system sites.
- Sanitary without a dead leg.

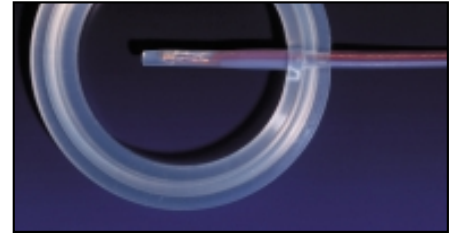

### Available Configurations for the Smart Gasket®

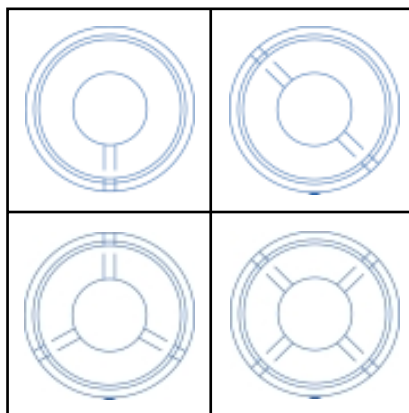

### Smart Gasket® Features:

- Safe to use.
- Ease of installation.
- 1, 2, 3 and 4 internal ports available.
- Sensors seal with hygienic seal compression.
- User friendly.
- Reusable.

Smart Gasket with Smart Clamp is available in 1/2", 3/4", 1", 1-1/2", 2", 3" and 4" sizes and fits standard sanitary flanges. Choose between EPDM, platinum-cured silicone, FKM and other elastomers.



### Spore Trap

You will never lose spore test strips in your process system again. The Rubber Fab Smart Gasket with the Spore Trap is designed to securely retain and accurately expose spore challenge test strips for use in steam sterilization when validating. After each validation cycle, the spore trap, with its securely retained test strip, can easily be removed and rechallenge.

### Spore Trap Benefits:

- Use in combination with the Smart Gasket Thermocouple Hygienic Seal for an accurate integration of sterilization and spore strip testing.
- 1 internal port available when utilizing the spore strip Smart Gasket.
- No need for custom fittings or weldments and is easily installed into your sanitary systems.
- Rubber Fab's Smart Gasket with Spore Trap holder is available with and without a thermocouple port.

### Our Promises to Purity

Our state-of-the-art facility assures superior quality control and purity of material with rigorous standards during each critical step of production. Rubber Fab Technologies Group offers superior surface finish and elastomer purity in our finished hygienic seals.

After production, Rubber Fab seals are inspected and packaged in our cosmetic particulate free box. A step ahead of standard packaging, our box is made with cosmetic quality material that gives you a product free of particulates. Each box is clearly labeled with product information for clear inventory control. Lot and batch numbers provide traceability at all times.

# Thermocouple Program

## Thermometer

**ACC-7001HT**

**ACC-7001HK**

### Temperature Range:

-90° to +400° C

130° to +752° F

### Resolution/Accuracy:

0.1° C, 0.2° F ±0.05% of reading

±0.7° C or 1.3° F.

Accuracy is specified for operating ambient temperature of 23° C ±5° C.

### Cold junction error for thermocouples:

For operating ambient temperature for 0° C to +18° C and +28° C to 50° C, and an additional error of ±0.03° C/per degree C, or ±0.03° F/per degree F.

Model ACC-7001H is a high-performance, precision hand-held instrument for the measurement of temperature using type T thermocouple probes.

This versatile instrument measures temperature in both °C and °F. The internal memory of the micro-computer stores the minimum and maximum measured temperature for instant recall via the LCD display.

## Extension Leads

**ACC-EXT-3MM-OAL-3 FEET**

**ACC-EXT-6MM-OAL-6 FEET**

**ACC-EXT-12MM-OAL-12 FEET**

Male to male (sub-miniature type T connectors) 26 gauge. Stranded type to thermocouple wire with blue PVC insulation.

## Temperature Probe

**ACC-K or T-199A-S (short)**

**ACC-K or T-199A-L (long)**

Short and long temperature probe for thermocouple gasket. Copper Constantan female socket and bootie.

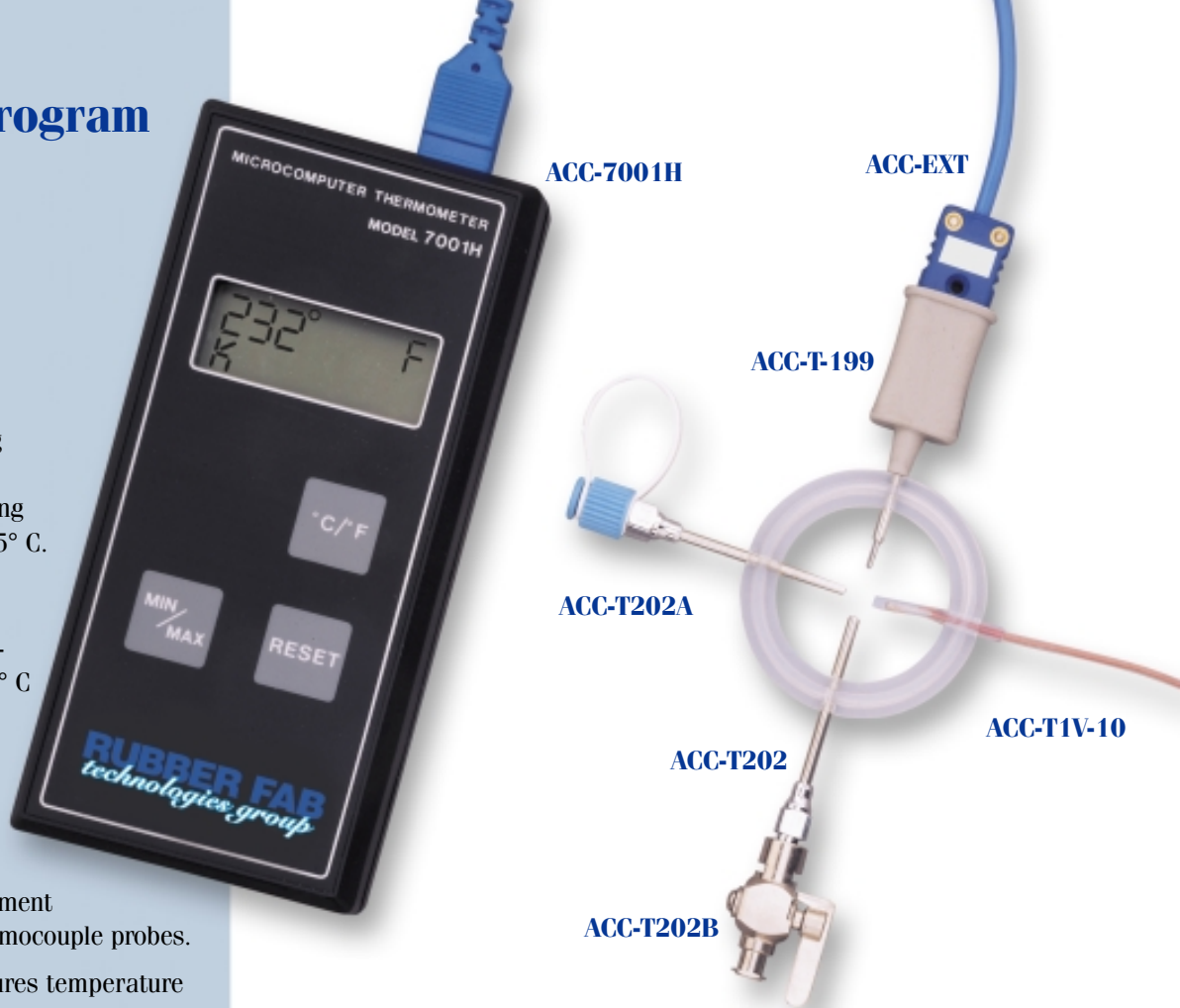

## Hole Plug

**ACC-T202A**

Chrome-plated brass head with stainless steel shaft 1-1/2" long .095 diameter.

## Sampling/Injection Tube

**ACC-T202**

Chrome-plated brass female luer head with 1-1/2" long stainless hypodermic tube .095 O.D., .071 I.D.

## Stopcock

**ACC-T202B**

To fit sampling/injection tube. Chrome-plated brass construction female luer fitting to male luer lock.

## Thermocouple Wire

**ACC-T1V-10**

**ACC-KV-10**

Coated thermocouple wire probe x 10' long with male mini quick disconnect connector for use with thermometer. Specify Kaptan or FEP when ordering.

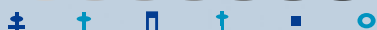

Rubber Fab Technologies Group  
Limecrest Road

P.O. Box 626 • Andover, NJ 07821

phone: 973-579-2959 fax: 973-579-7275

[www.rubberfab.com](http://www.rubberfab.com)

Rubber Fab Technologies Group is a member of:



International Association of  
Food Industry Suppliers



Distributed by:

Fluid Conditioning Technology By Rubber Fab

# SCREEN HYGIENIC SEALS

Protecting Products  
From Particulates

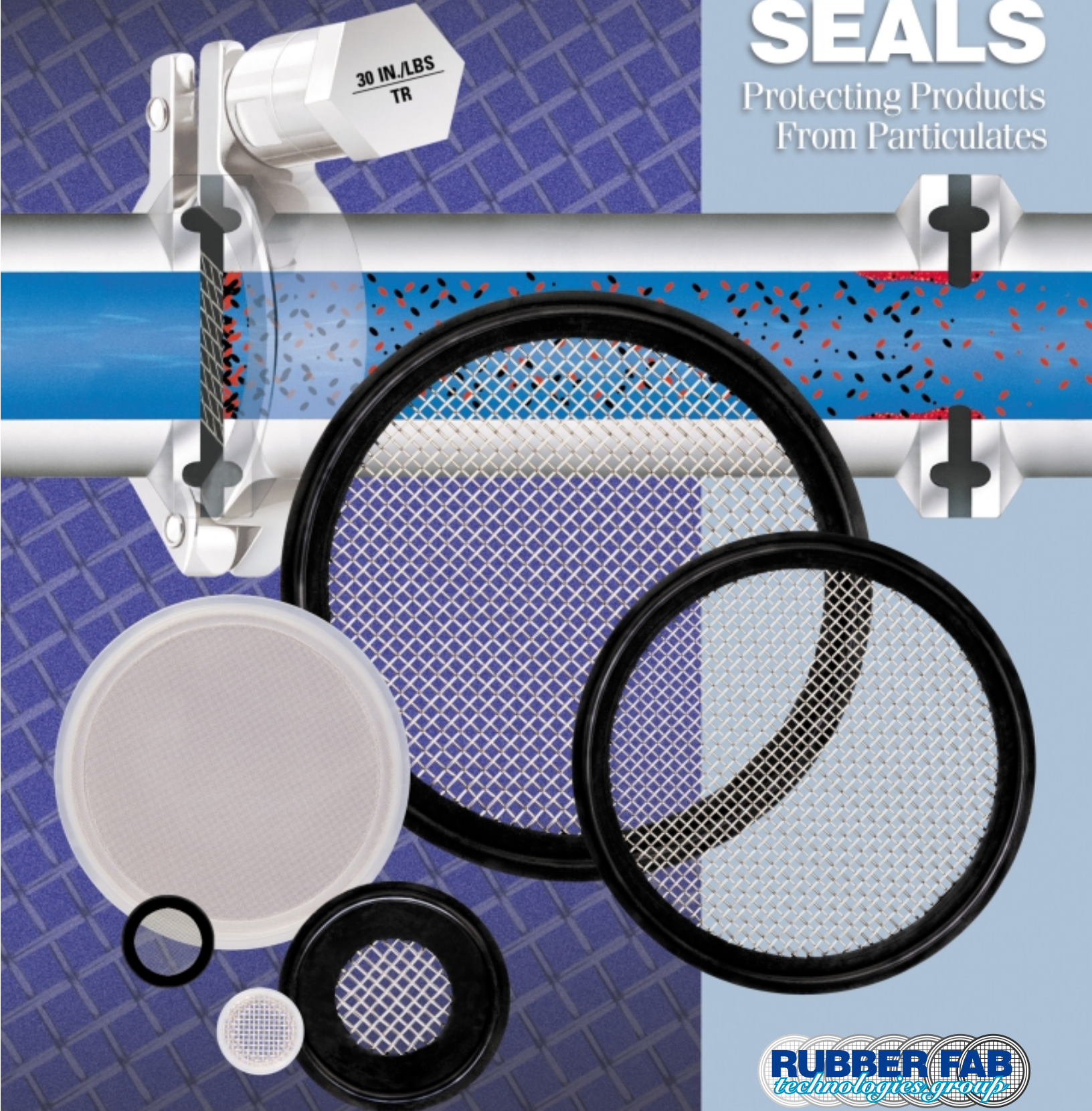

## Fluid Conditioning Seals

Rubber Fab's sanitary Fluid Conditioning Hygienic Seals are designed to be interchangeable with standard sanitary clamp gaskets.

## Metallic Screens

- 316 Stainless Steel
- Hastelloy - consult factory
- Stainless steel perforated

## Available Meshes

For in stock product, please see the Rubber Fab Fluid Conditioning Reference Chart on the back page.

## Available Sizes

- Mini, 1/2", 3/4"
- 1", 1-1/2", 2", 2-1/2", 3", 4" and 6" sanitary screen hygienic seals

## Applications

- Prefiltration for critical membrane filters
- Coalescence of water vapor from process exhaust lines
- Liquid gassing or degassing
- Large particulate removal before fill and finish
- Turbulence generation for enhanced mass or heat transfer
- Protection for pump, check valves, and other components
- Particulate removal in sterile filling operations
- Sparging
- Chromatography purification
- Metal Detectable Elastomers available

## Meets High Pharmaceutical Standards

- U.S. Pharmacopeia Class VI Certification
- Cytotoxicity Criteria
- Title 21 CFR 177.2600
- Title 21 CFR 177.1550
- USDA Sanitary Standards
- Current Good Manufacturing Practices (CGMP)
- ASME-BPE Standards
- Animal Derived Ingredient Free\*

© Tuf-Steel and ADI Free are registered trademarks of Rubber Fab Technologies Group.

Rubber Fab Technologies Group's Metal Detectable products are patent pending.

\* Buna in not an ADI Free elastomer.

## Rubber Fab's Fluid Conditioning Program

Rubber Fab offers a hygienic seal program for your consideration and employment. For the first time, you can chose the USP Class VI elastomer of your choice in a variety of mesh sizes, **10 micron through 4 mesh**, which are all normally available for shipment on the day of order. Our fluid conditioning hygienic seals are also **available with metal detectable elastomers**. We hope after you have reviewed the Rubber Fab Technologies Group's Fluid Conditioning Program, you will once again discover...***the Rubber Fab Difference.***

## Materials Available

Fluid conditioning hygienic seals are manufactured in the following elastomers:

- FKM Fluoroelastomer
- EPDM
- Platinum Silicone
- Buna\*
- PTFE (fluoropolymer)
- Tuf-Steel®

## Also Available

- Perforated fluid conditioning seals. Size range: 1"– 6".
- Complete elastomer selection
- Removable hygienic seal holders available for all discs
- Screen disc inserts
- Perforated disc inserts
- Orifice plate inserts

\* Buna-N does not pass U.S. Pharmacopeia Class VI Certification and Cytotoxicity.

## Perforated fluid conditioning seals

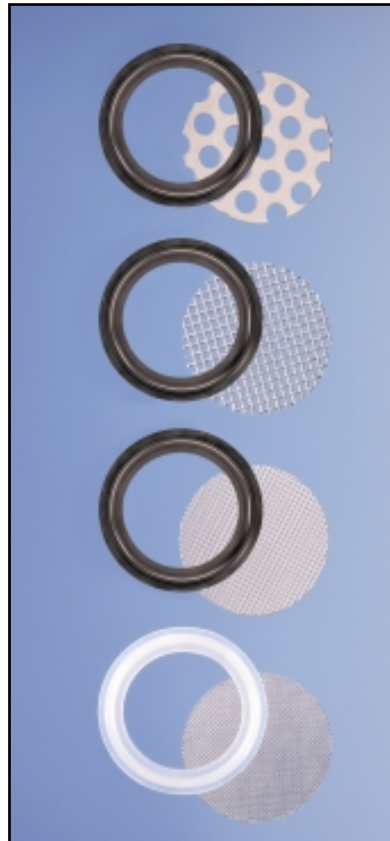
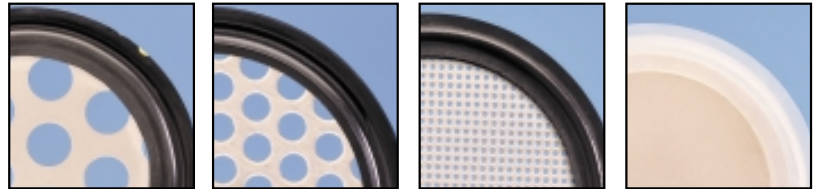

**Removable disc inserts and holders sold separately**

## Fluid conditioning sock designed for greater soil capacity

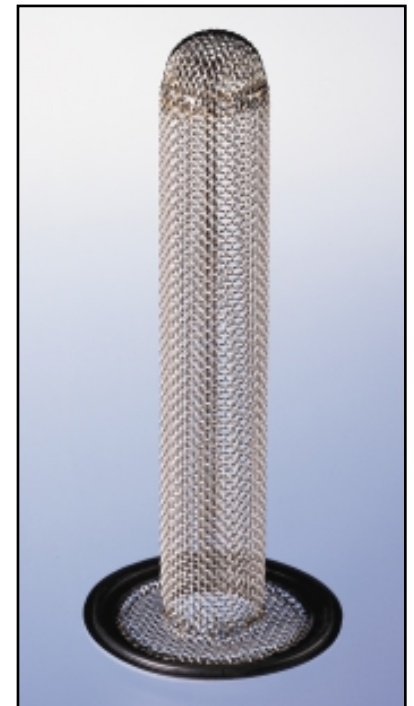

**Mesh sizes available: 10 mesh and 16 mesh**

## Range of Particulate Elimination

Fluid conditioning hygienic seals provide the most comprehensive range of stainless steel mesh and filter cloth which provide for **particulate elimination** to protect fill and finish sterile products. As illustrated, you can see a progressive particulate elimination utilizing **10, 20, 40, 60 and 100 mesh screens**.

We are also able to provide hygienic seals which will allow you to remove your screen disc, accept an orifice plate disc or membrane of choice, providing the membrane thickness **does not exceed .032 inches**.

**Sock designs are also available.** Sock designs are inserted into the I.D. of your stainless steel tubing and provide filtration when a greater soil burden is present.

**Please do not hesitate to contact us regarding your special needs and thoughts** as it pertains to your fluid conditioning program.

Photography presented here is actual size pertaining to **10, 20, 40, 60 and 100 mesh sizes**. For full product availability, refer to the Fluid Conditioning Reference Chart on the back page. **Screen construction is Dutch Twill weave for maximum strength and minimum pressure drop.** Perforated .033 seals are also available.

If elimination of particulates are critical to the **CGMP** in your injectable filled product, chromatography, columns, upstream particulate removal, downstream, filtration, as a reassurance, consider **Rubber Fab Technologies Group's Fluid Conditioning technology**.

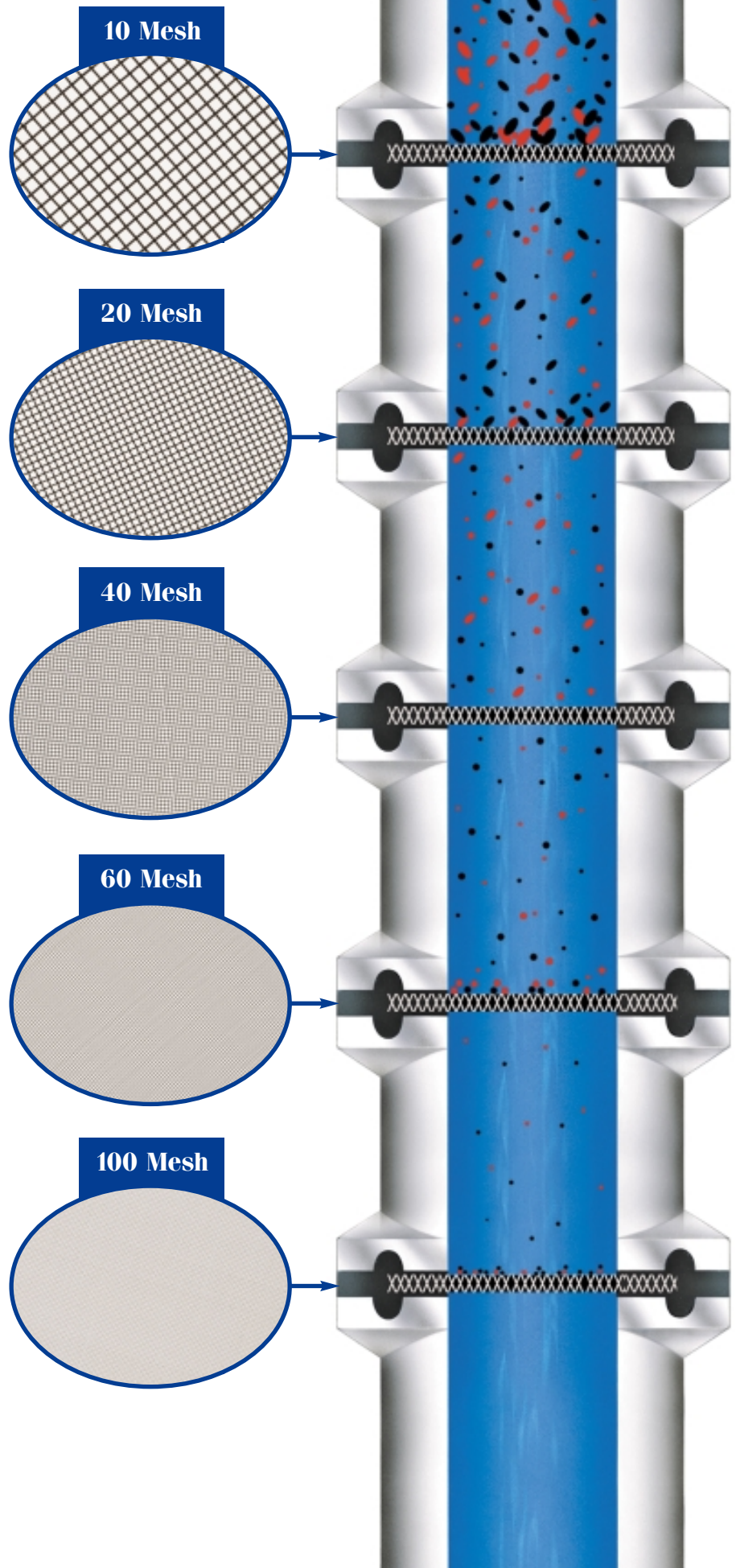

# RUBBER FAB

## Fluid Conditioning Reference Chart

**\*Stock Items in Stainless Steel 316.**  
 Also available: Hastelloy, Membrane Inserts, and PTFE Screen (limited mesh for removable gasket holders only).

Approx. Retention MICRONS	Square Mesh			Filter Cloth		
	Opening (Inches)	Mesh (Wires/Inch)	Wire Diameter	Cloth Thickness	Mesh	Cloth Thickness
5156	0.2030	4x4	0.047	0.094	—	—
3340	0.110	6x6	0.035	0.056	—	—
2464	0.0970	8x8	0.028	0.056	—	—
1905	0.0750	10x10*	0.025	0.050	—	—
1532	0.0603	12x12	0.023	0.048	—	—
1306	0.0514	14x14	0.020	0.040	—	—
1130	0.0445	16x16	0.018	0.036	—	—
1081	0.0426	18x18	0.013	0.026	—	—
979	0.0386	18x18	0.017	0.034	—	—
864	0.0340	20x20*	0.016	0.032	—	—
703	0.0277	24x24	0.014	0.028	—	—
516	0.0203	30x30	0.013	0.026	—	—
381	0.0150	40x40*	0.010	0.020	—	—
318	0.0125	50x50	0.0075	0.015	—	—
233	0.0092	60x60*	0.0075	0.015	—	—
225	—	—	—	—	16x100	0.038
168	0.0065	105x105	0.0030	0.006	—	—
160	—	—	—	—	24x110	0.035
140	0.0055	80x80*	0.0070	0.014	—	—
140	0.0055	100x100*	0.0045	0.009	—	—
120	—	—	—	—	30x160	0.023
118	0.0046	120x120	0.0037	0.007	—	—
110	0.0043	120x120	0.0040	0.008	—	—
103	0.0041	150x150	0.0026	0.005	—	—
96	—	—	—	—	20x200	0.0325
93	0.0037	150x150	0.0030	0.006	—	—
90	—	—	—	—	20x250	0.026
85	—	—	—	—	40x200	0.018
83	0.0033	180x180	0.0023	0.005	—	—
80	—	—	—	—	120x160	0.011
75	—	—	—	—	30x250	0.028
74	0.0029	200x200	0.0021	0.004	—	—
70	—	—	—	—	120x180	0.011
69	0.0027	200x200	0.0023	0.005	—	—
65	—	—	—	—	120x200	0.011
61	0.0024	250x250	0.0016	0.003	—	—
60	—	—	—	—	28x500	0.016
50	—	—	—	—	120x330	0.010
43	0.0017	325x325	0.0014	0.003	—	—
40	—	—	—	—	120x400	0.010
35	—	—	—	—	120x500	0.010
30	—	—	—	—	80x700	0.010
30	—	—	—	—	120x800	0.009
25	—	—	—	—	20x350	0.022
25	—	—	—	—	200x600	0.006
21	—	—	—	—	200x830	0.006
10	—	—	—	—	200x1150	0.006



± + ∏ † ■ ○

Rubber Fab Technologies Group  
 Limecrest Road

P.O. Box 626 • Andover, NJ 07821

phone: 973-579-2959 fax: 973-579-7275

[www.rubberfab.com](http://www.rubberfab.com)

Rubber Fab Technologies Group is a member of:

Distributed by:



International Association of Food Industry Suppliers



Distributors Serving Sanitary Processing

Rubber Fab's Tank Vent and Breaker System

# V<sup>2</sup>B GASKETS

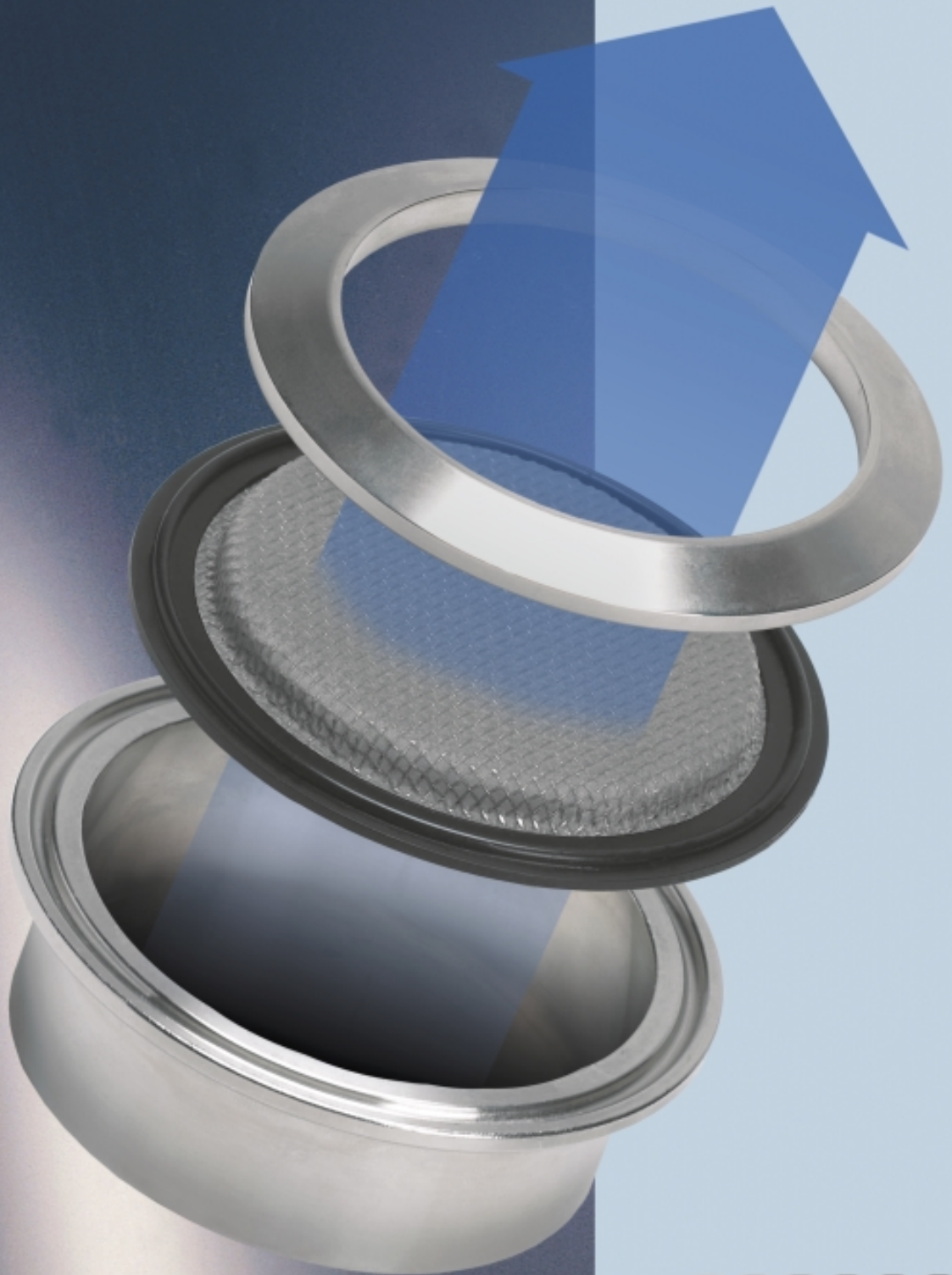

## V<sup>2</sup>B Gasket

- Sizes Available: 1-1/2" – 6"
- Removes atmospheric and environmental particulates
- Easy to maintain
- Easy to install
- 316 stainless steel construction
- V<sup>2</sup>B works as both a vacuum breaker and venting system
- Materials of construction are both lot and batch certifiable
- Elastomers available: Platinum silicone, FKM fluoroelastomer and EPDM
- All V<sup>2</sup>B gaskets are removable and replaceable
- Minimizes need for pre-air filters

## Meets High Pharmaceutical Standards

- U.S. Pharmacopeia Class VI Certification
- Cytotoxicity Criteria
- Title 21 CFR 177.2600
- USDA Sanitary Standards
- Good Manufacturing Practices (GMP)

## Presenting Rubber Fab's V<sup>2</sup>B Gasket: The Vent and Vacuum Breaker Gasket.

The Rubber Fab V<sup>2</sup>B Gasket offers an additional answer for vacuum and pressure relief for **pharmaceutical** and **food/beverage processing** tank venting when **airborne particulate removal is required**. Using a 200 mesh screen combined with a 14 mesh screen of **scintered construction**, Rubber Fab has created a cost effective alternative to expensive vacuum breakers and venting systems.

The V<sup>2</sup>B System is attached/connected using a standard sanitary clamp to a sanitary tank port, the same way a standard vacuum breaker is installed. **Installation can be horizontal, vertical or in single or multiple port configurations** (i.e. manifolds) without special

fabrication or expensive tooling. The V<sup>2</sup>B screen will **fit perfectly into the ID of a sanitary pipe** and can be used for **inflow fluid** conditioning filtration.

## Providing Air Flow Without Contamination.

A key benefit of the V<sup>2</sup>B Gasket is its **prevention from most atmospheric and environmental contamination** customarily found with other venting systems. Because the V<sup>2</sup>B Gasket can provide **unrestricted air flow with ultra fine filtration**, you can feel secure in knowing the **hygienic condition** of the tank contents remain protected. With regular cleaning and maintenance, the V<sup>2</sup>B Gasket is a **cost effective and incredibly simple** way to provide **contaminate free air flow** to any tank system.

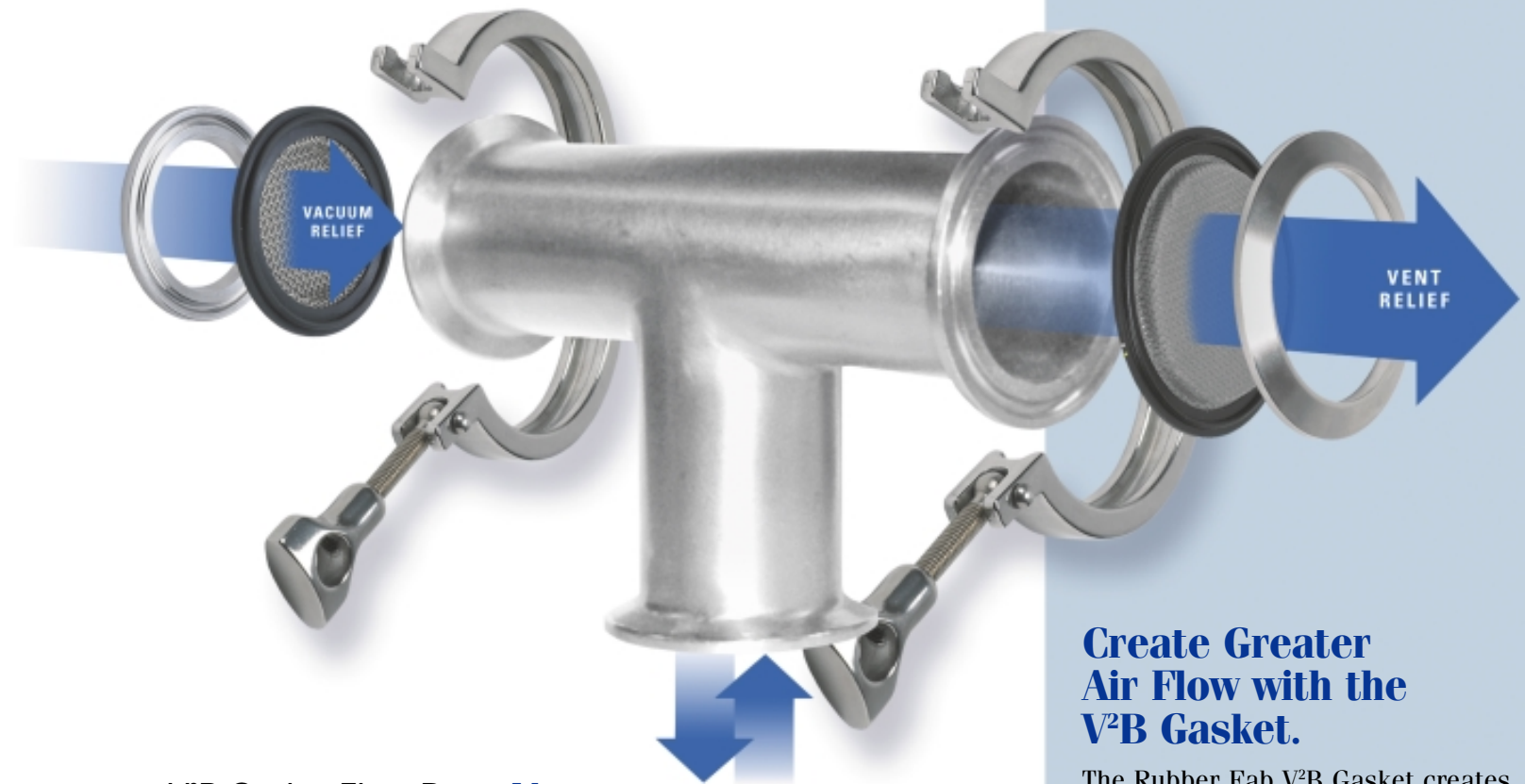

## Create Greater Air Flow with the V<sup>2</sup>B Gasket.

The Rubber Fab V<sup>2</sup>B Gasket creates the opportunity to **increase the flow of air** (or decrease if necessary). By using a concentric reducer as illustrated below, you can provide a 2 inch pipe flange 4 inches of air flow area. And by utilizing one or multiple 2-way and/or 4-way sanitary pipe adapters, you can **exponentially increase the air flow** in and out of your tank system while still **protecting the system from atmospheric debris**.

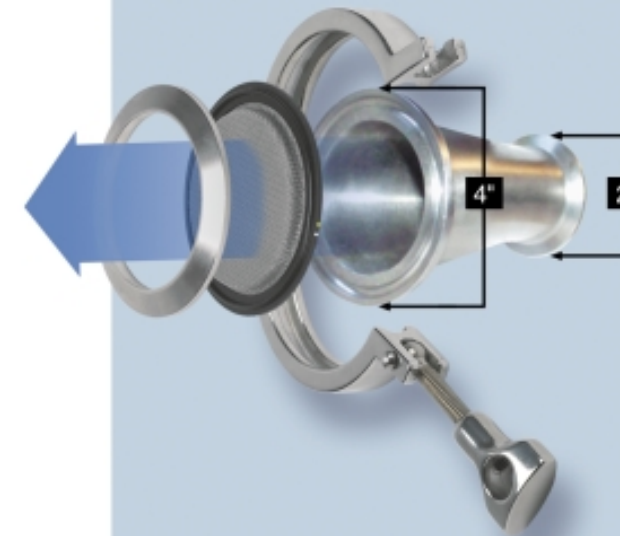

### V<sup>2</sup>B Gasket Flow Rate: Air

Line Size	CFM per unit		
1.5"	1.26 x 6.45* =	8.13 x .51** =	4.15
2"	2.46 x 6.45 =	15.87 x .51 =	1.52
2.5"	4.04 x 6.45 =	26.06 x .51 =	1.52
3"	6.02 x 6.45 =	38.83 x .51 =	1.52
4"	10.92 x 6.45 =	70.83 x .51 =	1.52
6"	25.34 x 6.45 =	163.44 x .51 =	1.52

\* Flow rate through 200 mesh .0021 wire diameter is 930 CFM. When divided by 144, equals 6.45 CFM per square inch.  
 \*\*% open area of 14 mesh .020 wire diameter.

### V<sup>2</sup>B Gasket Flow Rate: Water

Line Size	GPM per unit		
1.5"	1.26 x 16* =	20.16 x .51** =	10.28
2"	2.46 x 16 =	39.36 x .51 =	20.07
2.5"	4.04 x 16 =	64.64 x .51 =	32.97
3"	6.02 x 16 =	96.48 x .51 =	49.20
4"	10.92 x 16 =	174.88 x .51 =	89.19
6"	25.34 x 16 =	405.44 x .51 =	206.77

\* Flow rate of water through 200 mesh .0021 wire diameter is 16 GPM per square inch.  
 \*\*% open area of 14 mesh .020 wire diameter.

### V<sup>2</sup>B Gasket: Open Area

Line Size	Open Area sq/in		
1.5"	1.27 x 1.27 =	1.61 x .7854* =	1.26
2"	1.77 x 1.77 =	3.13 x .7854 =	2.46
2.5"	2.27 x 2.27 =	5.15 x .7854 =	4.04
3"	2.77 x 2.77 =	7.67 x .7854 =	6.02
4"	3.73 x 3.73 =	13.91 x .7854 =	10.92
6"	5.68 x 5.68 =	32.26 x .7854 =	25.34

Please consult factory for CFM/GPM calculations on additional sizes.

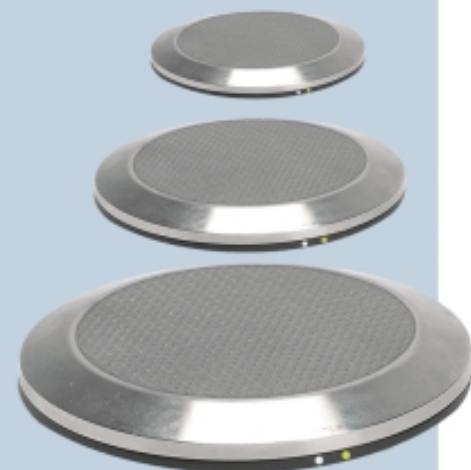

The V<sup>2</sup>B Gasket is available in a size range from 1-1/2" to 6"



## V<sup>2</sup>B Gasket

- Sizes Available: 1-1/2" - 6"
- Available as a **complete system** or as **individual components**
  - V<sup>2</sup>B Screen
  - V<sup>2</sup>B Gasket
  - V<sup>2</sup>B Vent Cap
  - Sanitary Clamp
  - Optional Torque-Rite®
- Use the V<sup>2</sup>B Gasket for:
  - **air flow and venting**
  - **vacuum relief**
  - **particulate removal**
  - **in-line fluid conditioning**
- Used in:
  - **pharmaceutical tanks**
  - **food and beverage processing**
  - **environmental incubation**
  - **clean room applications**
- Components available in electro polished finish.
- **Other mesh and micron sizes are available.** Consult Rubber Fab with special needs and requirements.

NOTE: The V<sup>2</sup>B Gasket is not intended for use in every existing vacuum breaker and venting situation. Rubber Fab Technologies Group recommends testing to determine the individual system's needs and requirements and its compatibility with the V<sup>2</sup>B Gasket. Rubber Fab Technologies Group suggests a regular cleaning cycle in order to maintain consistent water and air flow through the V<sup>2</sup>B Gasket. Due to the inherent risks in vertical silo and tank venting, Rubber Fab Technologies Group does not recommend the V<sup>2</sup>B Gasket without the use of traditional vacuum breakers.



Rubber Fab Technologies Group  
Limecrest Road

P.O. Box 626 • Andover, NJ 07821  
phone: 973-579-2959 fax: 973-579-7275

[www.rubberfab.com](http://www.rubberfab.com)

## The V<sup>2</sup>B Gasket: An Excellent Addition to Rubber Fab's Fluid Conditioning Program



Additional information is available on fluid conditioning technology in Rubber Fab's Screen Hygienic Seal brochure. Contact Rubber Fab Technologies Group at 973-579-2959 to receive copies of our literature.

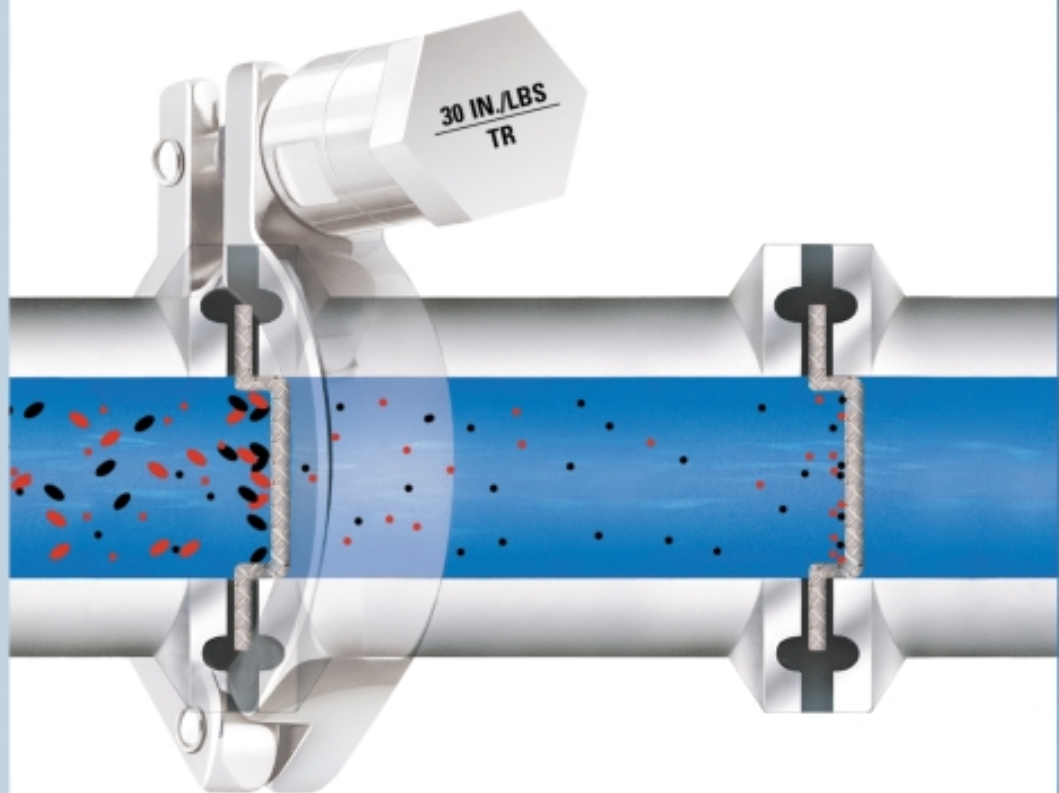

Rubber Fab Mold & Gasket is a member of:



Distributed by:



## Presenting Rubber Fab's Flow Reducing Orifice Plate Solution

There's a new standard in orifice plate design. Offered in a **concentric or eccentric self draining configuration**, the Rubber Fab Orifice Plate prevents dead legs, maintains flow while assuring self drainage thereby eliminating the potential for soil retention.

- Sizes available: Mini to 6"
- Most standard drilled bore sizes available
- Available in FKM Fluoroelastomer, Platinum Silicone, EPDM, Buna, PTFE and Tuf-Steel®
- Self draining
- Flow reducer
- Balance backpressure
- Blank plates are standard
- All Buna stocked with 1/8" hole
- Available with or without tab
- Engraved tabs
- Standard 15RA or better
- Electropolish finish available 10RA or better
- Custom cut pattern also available
- Metal Detectable Elastomers available

## Meets High Pharmaceutical Standards

- U.S. Pharmacopeia Class VI Certification
- Cytotoxicity Criteria
- Title 21 CFR 177.2600
- Title 21 CFR 177.1550
- USDA and 3-A Sanitary Standards
- Current Good Manufacturing Practices (CGMP)
- ASME-BPE Standards
- Animal Derived Ingredient Free\*

© Torque-Rite, Tuf-Steel and ADI Free are registered trademarks of Rubber Fab Technologies Group.

Torque-Rite: United States Patent Number 6,082,941.

\* Buna is not an ADI Free elastomer.



Rubber Fab Technologies Group  
Limecrest Road

P.O. Box 626 • Andover, NJ 07821  
phone: 973-579-2959 fax: 973-579-7275

[www.rubberfab.com](http://www.rubberfab.com)

## Rubber Fab Technologies Group's Unique Orifice Plate Program

Our innovative Orifice Plate line includes a complete selection from 1/2" through 6" size range in both **concentric and eccentric drilled plates as well as a solid plate design! Tabbed Orifice Plates** and clamps are available in 1/2" – 6". Tabs help to acknowledge that an orifice plate is "in the line" and are engraved to indicate the hole diameter. **A major safety consideration!** Rubber Fab's Orifice Plates can **advance your system's performance, adjust flow rates, balance backflow and equalize backpressure** during SIP procedures. Achievable benefits while maintaining sanitary conditions.

## Materials Available

Rubber Fab manufactures all models of our Orifice Plates in the following elastomers:

- FKM Fluoroelastomer
- Platinum Silicone
- EPDM
- Buna
- PTFE (fluoropolymer)
- Tuf-Steel®

All Orifice Plates are manufactured from 316L stainless steel and are available in electropolish construction.



Rubber Fab Technologies Group is a member of:



Distributed by:

Rubber Fab Technologies Group's

# SANITARY DIFFUSER GASKET

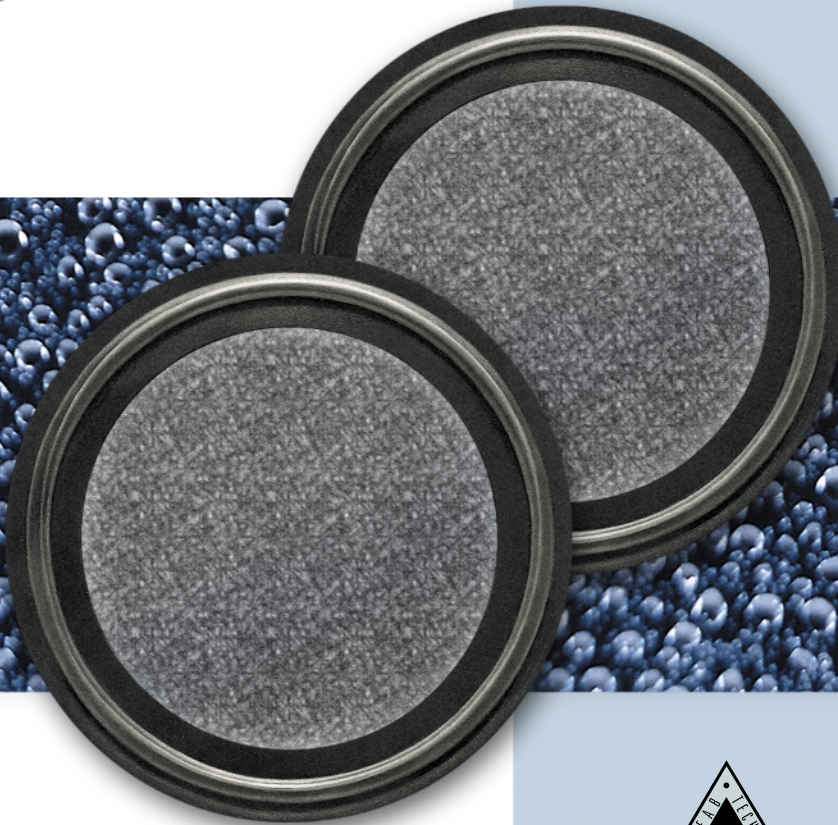

## Sanitary Diffuser Gaskets

Diffuser aeration systems provide increased oxygen content to high purity water systems. Diffusers can also be used to diffuse digester gases such as hydrogen sulfide and sulphur dioxide; to introduce ozone for oxidizing and destroying bacterial and organic chemical contaminants; and for carbon dioxide injection for recarbonization and pH adjustment. Manufactured from 316L Stainless Steel Porous Disc and molded with EPDM, FKM Fluoroelastomer or Silicone.

### Available in:

- Available Sizes: 1/2" – 3"
- Available Micron: 2 micron is standard stock, all other micron are custom, consult factory.

- 2 p.s.i. Push Gas required for 2 micron Diffuser Gasket.
- Metal Detectable Elastomers available.

### Meet High Pharmaceutical Standards

- U.S. Pharmacopeia Class VI Certification
- Cytotoxicity Criteria
- Title 21 CFR 177.2600
- USDA and 3-A Sanitary Standards
- Current Good Manufacturing Practices (CGMP)
- ASME-BPE Standards
- Animal Derived Ingredient Free

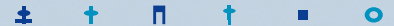

Rubber Fab Technologies Group  
Limecrest Road  
P.O. Box 626 • Andover, NJ 07821  
phone: 973-579-2959 fax: 973-579-7275  
[www.rubberfab.com](http://www.rubberfab.com)

Rubber Fab Technologies Group is a member of:



© ADI Free is a registered trademark of Rubber Fab Technologies Group.  
Rubber Fab Technologies Group's Metal Detectable products are patent pending.

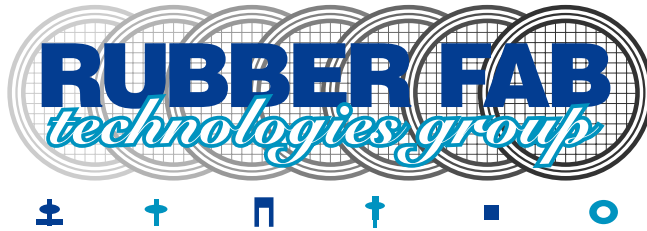

## HYGIENIC SEAL MATERIAL GUIDELINES

This information has been carefully prepared to help in selecting the correct elastomer or perfluorocarbon utilized in high purity sanitary hygienic seals where critical pure water, process fluids (both ambient and hot), and SIP environments exist. The intention is to consider the different uses, applications and conditions to determine **the most favorable hygienic seal material for each application.**

The following criteria is used in determining correct hygienic seal materials;

- **U.S. Pharmacopeia Class VI Certification**
- **Cytotoxicity Criteria**
- **CFR Title 21 Section 177.1550**
- **CFR Title 21 Section 177.2600**
- **Traceability: Lot and Batch**
- **Certification: Lot and Batch**
- **ASME-BPE Standards**
- **USDA Standards**
- **3-A Sanitary Standards**
- **Current Good Manufacturing Practices (CGMP)**
- **Manufacturer data and specifications**
- **Consultation with various pharmaceutical users**
- **Animal Derived Ingredient Free**

The gasket materials considered are Tuf-Steel® (PTFE/Stainless Steel), Tuf-Flex®, PTFE, Silicone (platinum), FKM Fluoroelastomer, EPDM and Buna.

**The 3 main goals are:**

- **To protect products from contamination**, spalling, particulates and TOCs resulting from the use of improper hygienic seal material.
- **To protect facilities from unnecessary downtime** associated with hygienic seal failure and replacement from use of improper hygienic seal material.
- **To provide a standard of consistency** for hygienic seal selection between multiple facilities.

Most decisions driving seal type selection are based on chemistry, temperature, exposure limits, USP, FDA qualifications, and curing methods. The following briefly addresses each of these issues.

## Exposure Limits

It is important to define the operating parameters of a new or existing processing sanitary system. The user specifications for exposure limits and reactivity to process fluids are compared with process operating parameters. All materials are acceptable for steam excluding Buna. All materials should meet **process fluid reactivity parameters**. Even though all compound exposure limits fall within operating parameters, the **service life** of some compounds will be different under certain conditions. This must be considered when selecting a compound.

## FDA and USP Qualifications

CFR's define the criteria for extractables and for compounds used in the manufacture of rubber and plastic articles. The two applicable categories are; rubber articles (Buna, EPDM, FKM Fluoroelastomer, Silicone) and perfluorocarbon resins (PTFE).

USP defines the criteria for testing biological reactivity and the amount/type of extractables. The hygienic seals in service must meet USP Class VI specifications, and be manufactured using the proper compounds as stated in the CFR, Title 21, Sections 177.1550 and 177.2600 respectively. Certificates are available from Rubber Fab Technologies Group verifying compliance with regulatory requirements, traceability lot and batch and certification lot and batch.

Note: Not all hygienic seals meet these requirements.

## Curing Methods

Curing agents have an affect on the amount and type of extractables a material will emit. Typically, the hygienic seal group in service uses three methods; **sulfur cured\***, peroxide cured and platinum cured. When dealing with elastomers, **peroxide cured** is the most favorable method. When dealing with silicone, **platinum cured** is the most favorable. All gaskets shall be post cured. Using these methods minimize potential reactions with the respective process fluid applications and can uphold pure water and process fluid standards.

\* **Sulfur cured** elastomers can significantly alter a process fluids integrity and negatively affect mammalian cell yields.

Note hygienic seal identification for curing methods. For example, EPDM: one green dot (●) means sulfur cured and three green dots (●●●) means peroxide cured.

**RUBBER FAB EPDM HYGIENIC SEALS ARE ALL PEROXIDE CURED.**

## What Material(s) Can Be Used

By reviewing manufacturer data and compiling information regarding regulatory requirements, it appears that any of the aforementioned compounds are suitable for both utility and process equipment use. However, you must ensure that all hygienic seals and compounds meet the CFR and USP requirements, and have a certificate to verify compliance.

# HYGIENIC SEAL MATERIAL GUIDELINES

## What Material(s) Should Be Used

- Tuf-Steel® is the material of choice when purity, **long service life** performance, chemical and heat resistance is required. Leak free when torqued correctly. Minimum creep and cold flow. Non-stick, ultra-low absorption and no pigmentation. Maintains seal integrity in applications where large temperature variations occur frequently. It can remain in service for **extended periods of time** in both water and frequent SIP use. The Torque-Rite® is recommended for use with clamps (See Torque-Rite literature for complete details).
- PTFE is the material of choice whenever low temperature flexibility or hygienic seal memory is not required (not recommended where large temperature variations occur frequently, leakage can occur). PTFE has almost no extractables, has a low absorption rate and excellent resistance to process fluids. It can remain in service for longer periods of time in both water and steam for continuous use, high pressure clamps are recommended to prevent leakage resulting from temperature variations. A PTFE envelope hygienic seal with an FKM Fluoroelastomer inner core should be used if slight misalignment is observed.
- Platinum cured silicone is the material of choice in sanitary water systems when PTFE is not feasible due to severely misaligned fittings, or if the cost of high pressure clamps does not outweigh the benefits of PTFE (extended service life).
- FKM Fluoroelastomer, EPDM and Buna compounds are specified by many of our process equipment manufacturers. They are generally suitable for these applications, however, service life must be considered and a **preventative maintenance program** be implemented to mitigate degradation. They are not recommended for continuous use in SIP procedures.

### Color coding - identification of hygienic seal materials

material	description	color code
Tuf-Steel®	no dot	
Tuf-Flex®	no dot	
PTFE	no dot	
PTFE Type 3 envelope seals		
FKM Fluoroelastomer filler	one white, one yellow dot	○ ●
EPDM filler	three green dots	● ● ●
FKM Fluoroelastomer	one white, one yellow dot	○ ●
EPDM*		
sulfur cured	one green dot	●
peroxide cured*	three green dots	● ● ●
Silicone		
peroxide cured	one pink dot	●
platinum cured	no dot	
Buna	one red dot	●

\* All Rubber Fab EPDM hygienic seals are peroxide cured.

# HYGIENIC SEAL MATERIAL GUIDELINES

1 = Excellent    2 = Good    3 = Acceptable    4 = Marginal    5 = Poor    X = Do Not Use

Gasket Comments	Continuous Stream	Intermittent Steam	Pure Water Ambient	Pure Water Hot	Process Fluids Ambient	Process Fluids Hot	Process Fluids Variable (<0°C->100°C)	Temp. Range
<b>Tuf-Steel®</b> Maintains seal with wide temperature variations. Has extended service life.*	1	1	1	1	1	1	1	-100°F to 500°F
<b>Tuf-Flex®</b> Maintains seal with wide temperature variations. Has extended service life.*	1	1	1	1	1	1	1	-100°F to 350°F
<b>PTFE</b> Wide temperature variations and may cause leakage at ΔT.	1	1	1	1	1	1	3	-100°F to 500°F
<b>Silicone (platinum)</b> Very flexible low temperature.	2	2	2	2	2	2	1	-40°F to 450°F
<b>FKM Fluoroelastomer</b> Acceptable for steam applications.	3	2	2	2	2	2	2	-30°F to 400°F
<b>EPDM (peroxide cured)</b> Low pressure steam only.	3	3	3	3	3	3	3	-30°F to 300°F
<b>Buna</b> Not recommended for strong acids and ozone.	0	0	5	5	5	5	5	-30°F to 200°F

\* Application dependent.

- **Tuf-Flex®:** Tuf-Flex is the world's only **unitized gasket**, setting new standards for purity, performance and flexibility. A Tuf-Flex Gasket's contact surface is a layer of PTFE unitized to an EPDM rubber inner core. This **totally bonded** construction provides a PTFE gasket with the mechanical characteristics, including memory, of an elastomer gasket. Designed to meet critical requirements in biopharmaceutical, ultra-pure water, WFI (water for injection) and difficult food and beverage processing, Tuf-Flex **out performs other gaskets** while eliminating costly process interruptions. Achieve higher performance under SIP/CIP conditions.
- **Tuf-Steel®:** A unique 50/50 blend of non-pigmented PTFE and 316L, water atomized and passivated, delivers **leak-proof performance**. Tuf-Steel is the choice for leak-proof, perfect surface performance and **outstanding durability** in SIP (steam in place) and WFI (water for injection) applications. Tuf-Steel is **ideal for sanitary steam pipe connections** in extreme temperatures ranging from -20°F to 500°F. The **superior strength** of Tuf-Steel **eliminates cold flow** and **creep** to prevent maintenance problems and system downtime.

- **PTFE** is the material of choice whenever low temperature flexibility or gasket memory is not required (not recommended where large temperature variations occur frequently, leakage can occur). PTFE has almost no extractables, has a low absorption rate and excellent resistance to process fluids. It can remain in service for longer periods of time in both water and steam for continuous use, high pressure clamps are recommended to prevent leakage resulting from temperature variations. PTFE envelope gaskets with a FKM Fluoroelastomer inner core should be used if slight misalignment is observed.
- **Platinum Cured Silicone** is the material of choice in sanitary water systems when PTFE is not feasible due to severely misaligned fittings, or if the cost of high pressure clamps does not outweigh the benefits of PTFE (extended service life).
- **FKM Fluoroelastomer** and **EPDM** compounds are specified by many of our process equipment manufacturers. They are generally suitable for these applications, however, service life must be considered and a preventative maintenance program be implemented to mitigate degradation. They are acceptable, but not recommended for continuous use in SIP procedures.

- **Buna** is the last choice in most applications due to temperature limitations and **does not pass U.S. Pharmacopeia Class VI Certification and Cytotoxicity**.

This sheet indicates general preferences. Unique applications may require further considerations and analysis. When selecting hygienic seal materials it is important to consider many factors: resistance to heat, resistance to SIP, resistance to chemicals like; hydrocarbons, ethanol, ketones, etc, tear strength, and flexibility. **The service life of a material depends on the application.** Many of the materials are acceptable if the expected service life is very short in duration, however, in extended exposure situations the material can degrade quickly rendering it ineffective or less desirable overall. This analysis was intended for hygienic seal applications specifically. Sanitary gasket applications are inherently static and can be dynamic. When different performance attributes are a consideration in dynamic applications, **Tuf-Steel** may be the material of choice.

© Torque-Rite, Tuf-Flex, Tuf-Steel and ADI Free are registered trademarks of Rubber Fab Technologies Group.

Torque-Rite: United States Patent Number 6,082,941.

Rubber Fab Technologies Group's  
**The Perfect Surface  
Hygienic Seal  
System**

Featuring Torque-Rite®  
and the Perfect  
Surface Hygienic Seal



# Torque-Rite®

Presenting Rubber Fab's **Perfect Surface Hygienic Seal System**. The perfect union of Torque-Rite and the family of Perfect Surface Hygienic Seals.



## The Perfect Surface System

$$\frac{\text{Torque-Rite}}{\text{Perfect Surface Hygienic Seal}} = \frac{\text{Compression Control}}{\text{Expansion Control}} = \text{Perfect Surface}$$

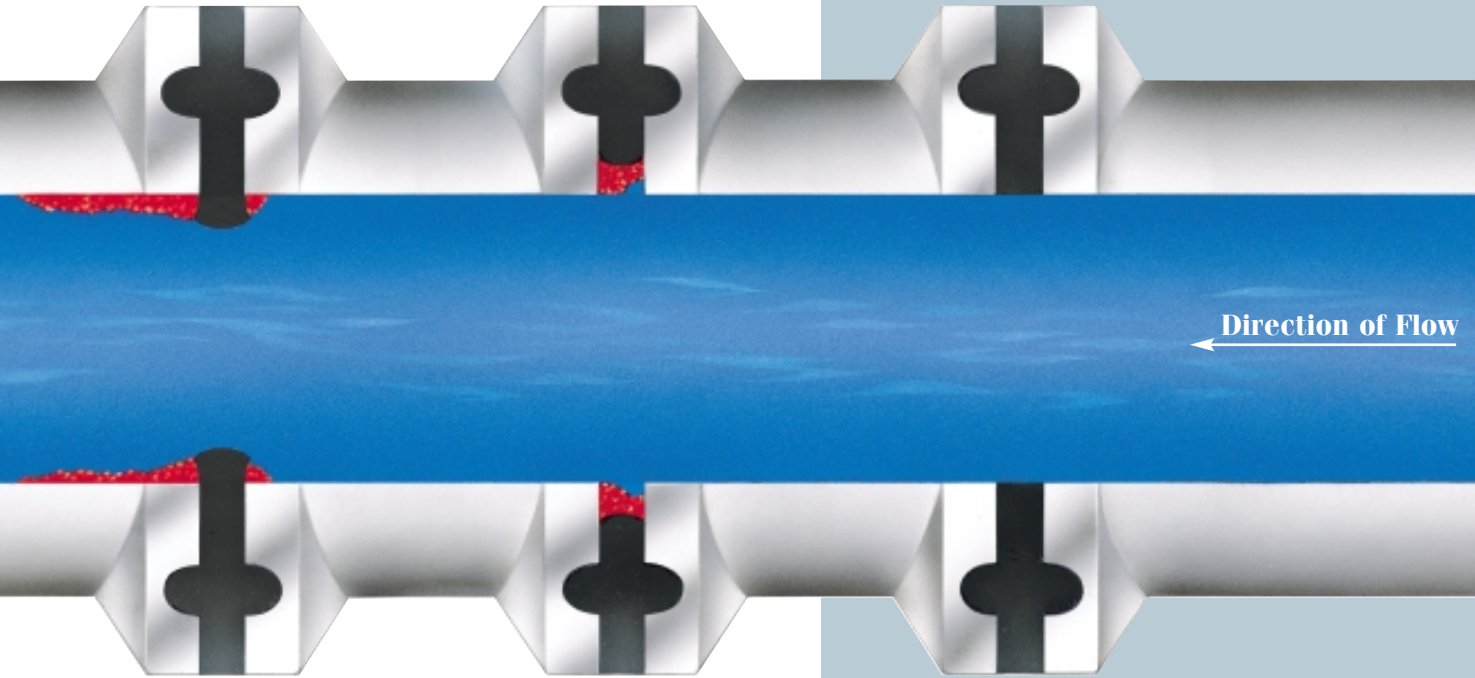

← Direction of Flow

**DAMMING:**  
An over-tightened hygienic seal extrudes into the pipe, prevents draining, and allows deposits to build up behind the gasket.

**UNDER-TIGHTENING:**  
May allow leakage. Can form concave surfaces at the product side of the hygienic seal affecting free drainage and cleaning.

**PERFECT SURFACE HYGIENIC SEAL SYSTEM:**  
Torque-Rite and Perfect Surface Hygienic Seal eliminates the concerns associated with over- and under-tightening a hygienic seal. Insures that seal I.D. matches pipe I.D.

**Torque-Rite** allows you to control compression and expansion while maintaining constant inch/pounds force insuring a Perfect Surface I.D. when used with a **Perfect Surface Hygienic Seal**. Torque-Rite eliminates the problems associated with over- or under-tightening a seal which can lead to an unsanitary system.

### Compression control is easy!

When tightened, the Torque-Rite's self-limiting internal mechanism will make an audible "click" signaling the user they have reached proper inch/pounds force. If further tightening is attempted, there will be more "clicks" but no additional application of force on the hygienic seal (if emergency conditions arise, the Torque-Rite has a built-in manual override feature).

## Problems with over-tightening or under-tightening a hygienic seal:

Over-tightening can tear or damage a seal and can also cause a damming effect inside the pipeline. A torn or extruded seal can hold soil and bacteria. Under-tightening leaves an undesirable concave area at the seal allowing soil and bacteria to become entrapped. Both conditions should be avoided in a sanitary system.

## Maintaining a "Perfect Surface" Sanitary System.

By maintaining a constant force on a Perfect Surface Hygienic Seal with the Torque-Rite, seal I.D. is maintained lowering bacteria count and enhancing product integrity.

**A Perfect Surface sanitary system is assured.**

## Torque-Rite Specifications.

Material: 440C Stainless Steel  
Hardness: 48 Rockwell  
Overall Height: 1.670"  
Driving Hex: .875 (7/8")  
Body Diameter: .875"  
Override Flats: .8125 (13/16")  
Lot Traceable

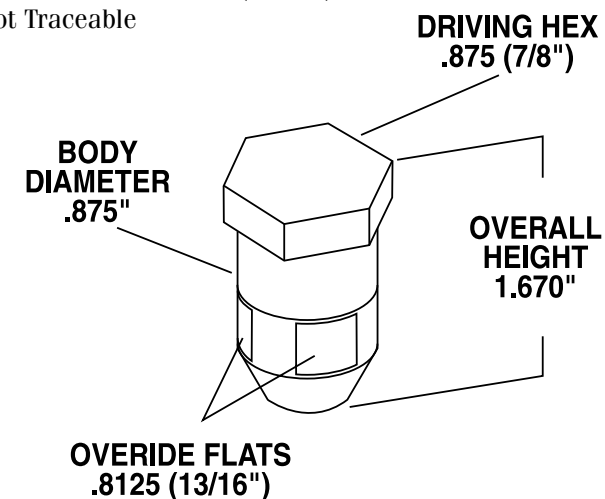

## Torque-Rite is available in two models.

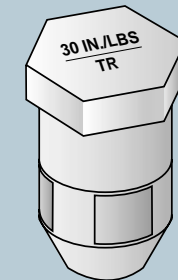

**Model**  
TR-30

**Perfect Surface Hygienic Seal Material**  
Buna  
Silicone  
FKM  
Fluoroelastomer  
EPDM

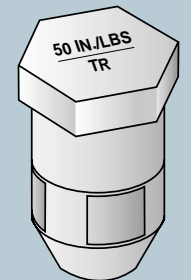

**Model**  
TR-50

**Perfect Surface Hygienic Seal Material**  
PTFE  
Tuf-Flex®  
Tuf-Steel®  
PTFE Envelope

## Perfect Surface Hygienic Seal Benefits:

- Lower bacteria counts
- Maintains/enhances product integrity
- **Insures that hygienic seal I.D. matches pipe I.D.**
- Passes **US Pharmacopeia Class VI Certification**
- Passes **cytotoxicity criteria**
- Complies with **Title 21 CFR 177.2600**
- Complies with **Title 21 CFR 177.1550**
- Complies with **USDA and 3-A sanitary standards**
- **Conforms to CGMP** (Current Good Manufacturing Practices)
- **Metal Detectable Elastomers available**
- **Animal Derived Ingredient Free**

## Torque-Rite® Features:

- An **audible “click”** indicating correct inch/pounds force
- **Maintains constant 30 or 50 inch/pounds force**
- **Manual override feature**
- **Retrofits all sanitary clamps, mini through 6”**
- **Works in rupture disk applications**
- **Works with all Smart Gasket® products** including spore trap, thermocoupler and sampler
- **No torque wrench or special training required**
- **User friendly**

NOTE: All elastomeric hygienic seals require periodic replacement. Seal life is influenced by the seal material, product application, temperature, cleaning procedures, etc. After monitoring seal condition in a process system, a schedule should be developed for periodic replacement of hygienic seals.

© Smart Gasket, Torque-Rite, Tuf-Flex, Tuf-Steel and ADI Free are registered trademarks of Rubber Fab Technologies Group.

Torque-Rite: United States Patent Number 6,082,941.

Rubber Fab Technologies Group's Metal Detectable products are patent pending.



Rubber Fab Technologies Group  
Limecrest Road

P.O. Box 626 • Andover, NJ 07821

phone: 973-579-2959 fax: 973-579-7275

[www.rubberfab.com](http://www.rubberfab.com)

## New From Rubber Fab Technologies Group



**Design...Validation...Production  
...Quality Assurance**

*Improving Product Quality  
and Consistency.*

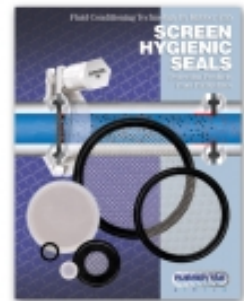

*Rubber Fab Technologies Group, a Material Science Company, is a leading innovator of high quality sanitary hygienic seals, hose assemblies, valve, pump and filler machine components in a wide range of high purity elastomer materials. For additional information, contact Rubber Fab at 973-579-2959 or visit us at [www.rubberfab.com](http://www.rubberfab.com).*

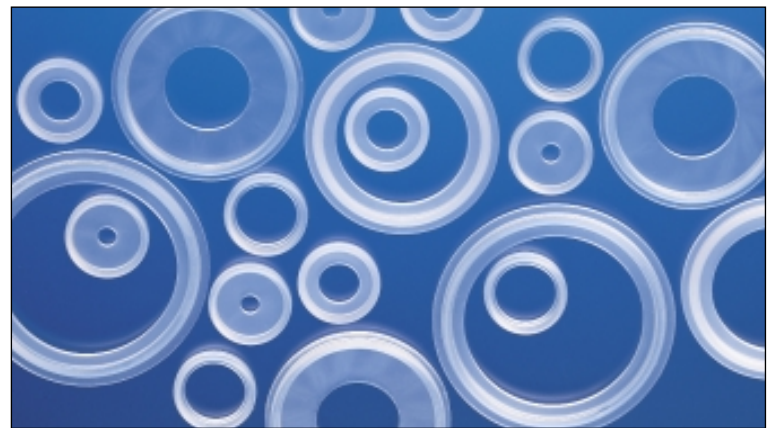

Rubber Fab Technologies Group is a member of:

Distributed by:



The PTFE and Stainless Steel Gasket

**TUF-STEEL**<sup>®</sup>

The Next Generation



## Presenting TUF-STEEL®: The S.I.P. Leak Proof Solution

There's a new standard in S.I.P. (steam in place) hygienic seal stability and longevity. With a unique 50/50 blend of non-pigmented PTFE and 316L water atomized and passivated stainless steel, Tuf-Steel is one tough gasket.

### Tough Under S.I.P. Conditions

- Superior creep resistance
- Minimal thermal expansion
- Excellent chemical resistance
- No pigmentation
- Passivated to eliminate rouging
- Stops leaks when torqued correctly (50 in./lbs.)
- No seal extrusion into the sanitary tube I.D.
- No obstruction of flow
- Non-stick surfaces
- Excellent expansion and contraction stability
- Maintains sealing stability in  $\Delta T$  processes
- I.D. pharmaceutical finish
- Available sizes: 1/2" – 12"
- Metal detectable

### Meets High Pharmaceutical Standards

- U.S. Pharmacopeia Class VI Certification
- Cytotoxicity Criteria
- USDA and 3-A Sanitary Standards
- Current Good Manufacturing Practices (CGMP)
- ASME-BPE Standards
- Animal Derived Ingredient Free

© Torque-Rite, Tuf-Steel and ADI Free are registered trademarks of Rubber Fab Technologies Group.

Torque-Rite: United States Patent Number 6,082,941.

Rubber Fab Technologies Group's Metal Detectable products are patent pending.



Rubber Fab Technologies Group  
Limecrest Road

P.O. Box 626 • Andover, NJ 07821  
phone: 973-579-2959 fax: 973-579-7275

[www.rubberfab.com](http://www.rubberfab.com)

## TUF-STEEL, the Next Generation Gasket

Tuf-Steel easily outperforms standard solid PTFE and PTFE envelope seals under even the most demanding S.I.P. pharmaceutical applications. In fact, Tuf-Steel lasts at least five times longer in most applications!

### Prevents System Downtime

The unparalleled strength of Tuf-Steel eliminates maintenance needs and helps prevent system downtime by eliminating cold flow creep. This makes Tuf-Steel ideal for sanitary steam pipe connections in

both extreme cold (down to -100°F) and hot conditions (up to 500°F). Tuf-Steel hygienic seals are available in a variety of sanitary standard sizes from 1/2" to 12" diameter to service virtually any S.I.P. application.

Plus, Tuf-Steel works with the Torque-Rite™ Perfect Surface Hygienic Seal System. This eliminates the potential for bacterial entrapment problems caused by over-tightening or under-tightening a hygienic seal (for greater details, see The Perfect Surface Hygienic Seal System brochure by Rubber Fab).

### The Exclusive Properties Of TUF-STEEL

Property	ASTM Method	Value
Specific Gravity	D792	3.45
Tensile Strength	D4894	1928psi
Elongation @ Break	D4894	270%
Compressive Stress @ 1%	D695	832
Compressive Stress @ 5%	D695	2590
Compressive Modulus	D695	84200
Hardness	D2240	68
Temperature Low	Continuous	-100°F
Temperature High	Continuous	500°F

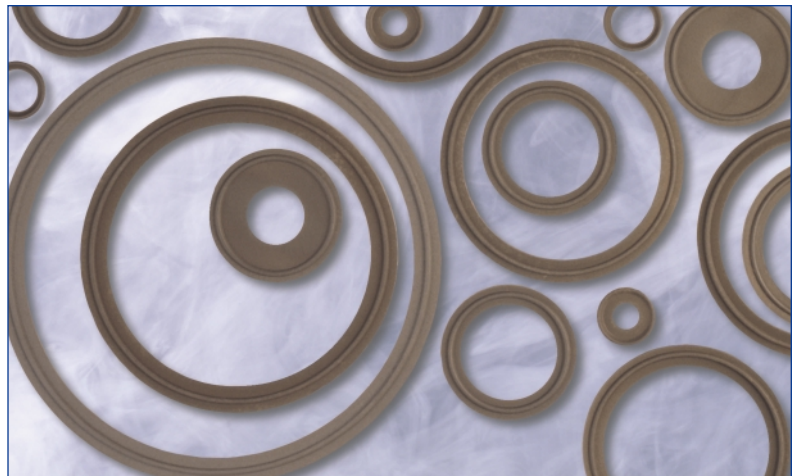

Rubber Fab Technologies Group is a member of:



Distributed by:

Rubber Fab Technologies Group's

# BIOLOGICAL INDICATOR GASKET

The "New" Smart Gasket®

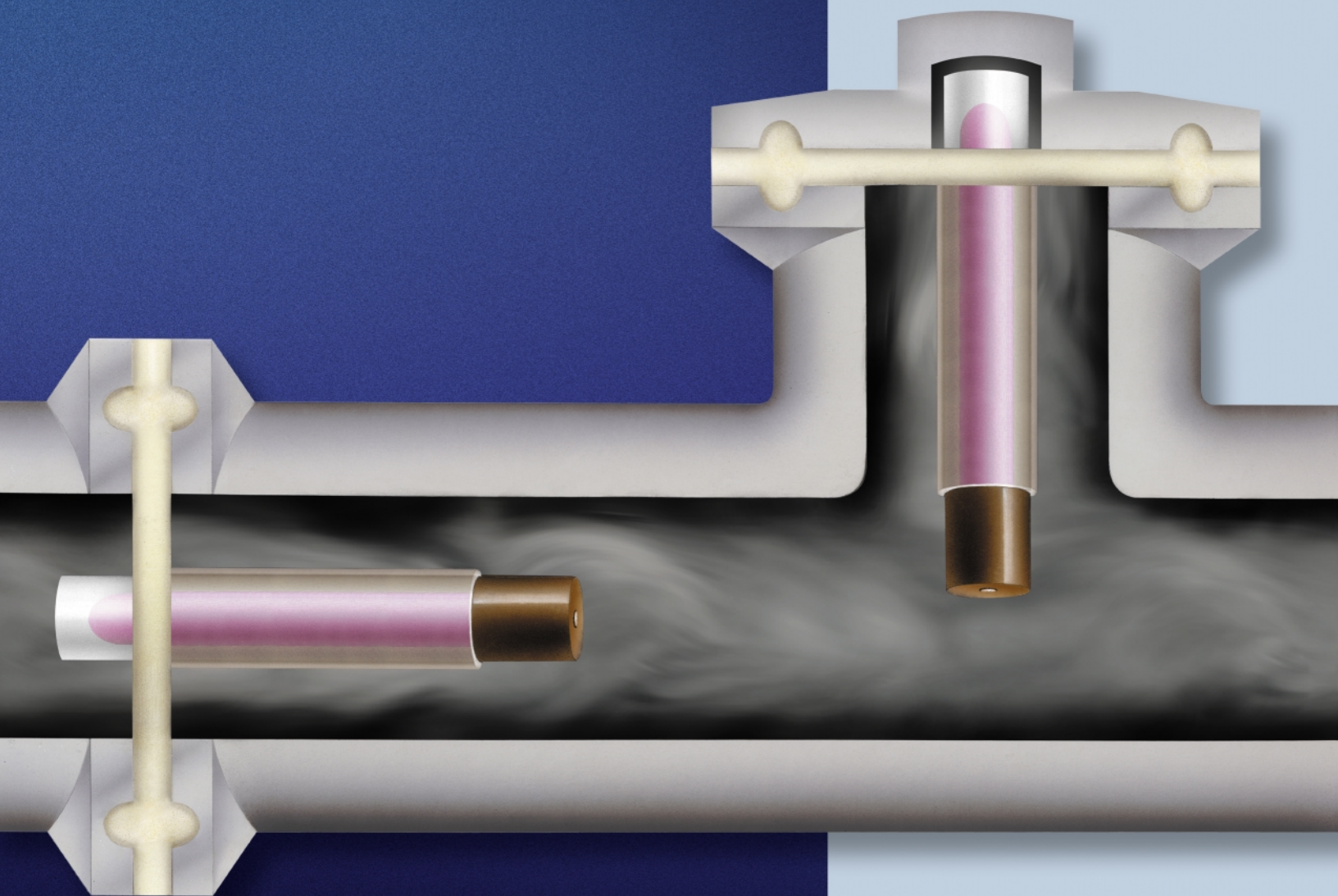

## The Biological Indicator Gasket

Rubber Fab is proud to introduce a new product that enables the use of a **self contained biological indicator** in sanitary process lines. This unique Rubber Fab Smart Gasket® permits either top loading or inline positioning of an **EZTest® self contained biological indicator and/or a temperature probe**.

The great advantage of a **self contained biological indicator** over the traditional spore strip in glassine is **the time saved** when confirming spore kill. **Results are easily obtained in only 24 hours** (versus the five to seven days required with a spore strip) **and without problematic laboratory transfer**.

You can feel secure knowing that the **biological indicator** will not be lost down stream in the process. The fail-safe Rubber Fab Smart Gasket holds the indicator in place for **easy retrieval**. Available for 3/4", 1.0", 1.5" and 2.0" Sanitary, Tri-Clamp process lines.

## Meets High Pharmaceutical Standards

### Biological Indicator Gasket

- U.S. Pharmacopeia Class VI Certification
- Cytotoxicity Criteria
- CFR Title 21 Section 177.2600
- Traceability: Lot and Batch
- Certification: Lot and Batch
- ASME-BPE Standards
- USDA Standards
- 3-A Sanitary Standards
- Current Good Manufacturing Practices (CGMP)
- Metal Detectable Elastomers available
- Animal Derived Ingredient Free

### EZTest®

- U.S. Pharmacopeia
- ISO 11138
- European Norm 866



Rubber Fab Technologies Group  
Limecrest Road

P.O. Box 626 • Andover, NJ 07821  
phone: 973-579-2959 fax: 973-579-7275

[www.rubberfab.com](http://www.rubberfab.com)



Additional technical and usage information about the EZTest® biological indicator and related testing products is available at [www.sgmbiotech.com](http://www.sgmbiotech.com).

## Validation of Steam Systems

- Fermenters
- Sanitary Inline Pipe
- Pharmaceutical Tanks
- Pharmaceutical Hose

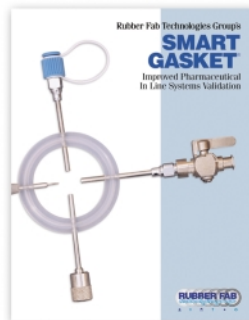

## Smart Gasket Technology

The Biological Indicator Gasket is also available with one (1) Smart Gasket® Thermocouple Port.

See Rubber Fab's Smart Gasket literature on our website for more information on Rubber Fab's other inline system validation products.

© Smart Gasket and ADI Free are registered trademarks of Rubber Fab Technologies Group.

Biological Indicator Gasket: United States Patent Number 6,927,058.

Rubber Fab Technologies Group's Metal Detectable products are patent pending.

© EZTest is a registered trademark of SGM Biotech, Inc.

**SGM BIOTECH, INC.**

Rubber Fab Technologies Group is a member of:



Distributed by:

Rubber Fab Technologies Group's

# METAL DETECTABLE ELASTOMERS



Metal Detectable  
FKM and SILICONE

Metal Detectable  
**TUF-STEEL™**  
*for hot oil applications*

Metal Detectable  
EPDM and BUNA

Rubber Fab: Helping Prevent Product Contamination With Cost Effective Solutions

As a result of excessive use, shearing and damage can occur to equipment causing undetectable product contamination. Metal detectables can eliminate product recall, lower product loss and decrease the risk of elastomers consumed in finished product.

Specially Made for the Meat and Poultry Industries

Tuf-Steel™ metal detectable hygienic seals can be used on 500° F continuous hot oil applications used in the Meat and Poultry Industries.

## System Protection with Metal Detectable Elastomers

Conductive and Magnetic Metal Detectable OEM Equipment From Rubber Fab

A common problem with component and filler parts is **excessive wear and tear**. When rubber breaks off a moving part **it can migrate through your system and into your product**. Searching for and locating fragmented rubber parts is a **costly, time consuming and inconclusive process** requiring expensive **x-ray equipment**, manual observation and an extensive maintenance program. **Not locating a worn and lost rubber piece can have an even costlier outcome.**

Rubber Fab provides an easy and cost effective solution with **metal detectable elastomers**. By manufacturing a standard elastomer with a **metal impregnated compound**, displaced rubber material can now be **located by an in-line metal detector**. This alarm enables your system to **instantly reject contaminated product**.



*Excessive wear can result in the shearing off of an elastomeric fragment which can cause undetectable product contamination*

## Metal Detectable Elastomers

- Easily detect lost elastomeric fragments.
- Prevent product recall.
- Lower product loss.
- Stop distribution of contaminated product.
- For use in standard OEM equipment.
- Designed for microbial, high-temperature and mechanical applications.
- Available in hygienic seals, screens, sheets, extrusions, valve stems and filler boots. Consult factory for other metal detectable products.

## Detectables are available in:

- Buna
- EPDM
- FKM
- Silicone
- Tuf-Steel™

## Meets High Standards

- Elastomers meet Title 21 CFR 177.2600
- Tuf-Steel meets Title 21 CFR 177.1550
- Meets USDA Hazard Analysis and Critical Control points.
- Detectable metal additive meets the latest revision of the Food Chemicals Codex\*.
- Animal Derived Ingredient Free†

\* The Food Chemicals Codex Project is an activity of the food and nutrition board of the Institute of Medicine and is supported by the U.S. Food and Drug Administration.

™ Tuf-Steel and ADI Free are trademarks of Rubber Fab Technologies Group.

Rubber Fab Technologies Group's Metal Detectable products are patent pending.

† Buna is not an ADI Free elastomer.

Rubber Fab Technologies Group, a Material Science Company, is a leading innovator of high quality sanitary hygienic seals, hose assemblies, valve, pump and filler machine components in a wide range of high purity elastomer materials. For additional information, contact Rubber Fab at 973-579-2959 or visit us at [www.rubberfab.com](http://www.rubberfab.com).

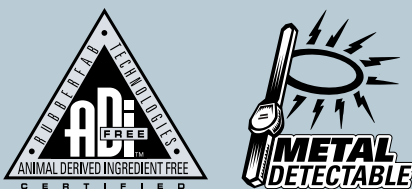

Rubber Fab Technologies Group  
Limecrest Road

P.O. Box 626 • Andover, NJ 07821  
phone: 973-579-2959 fax: 973-579-7275

[www.rubberfab.com](http://www.rubberfab.com)

Rubber Fab Technologies Group is a member of:



Distributed by:

# RF-PVC

## Spiral Reinforced PVC Suction Hose

### RF-SD – Standard Duty – Clear, Convoluted O.D.

ID (IN.)	OD (IN.)	WORKING PSI AT 70°F	BURST PSI AT 70°F	VAC. RATE IN/Hg	BEND RADIUS (IN.)	LBS. PER 100 FT.	PART NO. FOOD GRADE
1	1-1/4	60	180	28	2	19.0	RF310101
1-1/4	1-5/8	50	150	28	3	29.0	RF310178
1-1/2	1-13/16	50	150	28	3	34.0	RF310255
1-3/4	2-3/32	45	135	28	4	40.0	RF310332
2	2-3/8	45	135	28	4	50.0	RF310409
2-1/4	2-5/8	40	120	28	5	55.0	RF310486
2-1/2	2-15/16	40	120	28	6	77.0	RF310563
3	3-7/16	35	105	28	8	102.0	RF310640
4	4-9/16	35	105	28	10	164.0	RF310717

Standard coil length is 100 ft.

### RF-HD – Heavy Duty – Clear†, Smooth O.D.

ID (IN.)	OD (IN.)	WORK. PSI AT 70°F	BURST PSI AT 70°F	VAC. RATE IN/Hg	BEND RADIUS (IN.)	LBS. PER 100 FT.	PART NO. INDUSTRIAL GRADE	PART NO. FOOD GRADE
3/4	15/16	105	315	28	3	20.0	RF320180	RF320181
1	1-1/4	100	300	28	3	27.0	RF320257	RF320258
1-1/4	1-1/2	95	285	28	3	30.0	RF320334	RF320335
1-1/2	1-13/16	85	255	28	4	40.0	RF320411	RF320412
2	2-3/8	80	240	28	5	60.0	RF320488	RF320489
2-1/2	2-7/8	75	225	28	7	85.0	RF320565	RF320566
3	3-7/16	65	195	28	8	115.0	RF320642	RF320643
3-1/2	3-15/16	60	180	28	9	135.0	RF320719	RF320720
4	4-1/2	50	150	28	10	175.0	RF320796	RF320797

Standard coil length is 100 ft.

†Food Grade is all Clear; Industrial Grade has a White Helix.

### RF-LD - Light Duty - Clear with White Helix, Convoluted O.D.

ID (IN.)	OD (IN.)	VAC. RATE IN/Hg	BEND RADIUS (IN.)	LBS. PER 100 FT.	PART NO.
3/8	.570	24	1/2	5.0	RF330176
1/2	.700	24	1/2	6.0	RF330253
5/8	.830	24	5/8	8.0	RF330330
3/4	.965	24	3/4	10.0	RF330407
1	1-1/4	24	1	14.0	RF330484
1-1/4	1-1/2	22	1	15.0	RF330561
1-1/2	1-13/16	20	2	20.0	RF330638
2	2-3/8	18	2	34.0	RF330715

This series has no positive pressure ratings. Increasing pressure will cause the hose to elongate and expand. If pressure is a concern, in-plant testing is advised. Standard coil length is 100 ft. Cut coils are available; charges apply — call for details.

### Physical Properties\*

	RF-SD	RF-LD
Hardness, Shore A ±5	65	70
Tensile Strength, psi	1900	2000
Elongation at Break, %	440	420
Brittle Temperature, °F	-45	-42
Max. Operating Temp., °F	150	140

\* Values listed are typical and are meant only as a guide to aid in design. Field testing should be performed to find the actual values for your application.

- **100% PVC construction**
- Spiral reinforcement made from rigid PVC to **resist impact, crushing, and kinking**
- **Lighter than ply-wrapped rubber** and similar hoses
- **Available in Food and Industrial Grades**
- Food Grade made from non-toxic ingredients, **meeting FDA, 3A, and USDA standards**
- **Low friction loss and maximum flow** via smooth interior

This family of PVC products includes one of the widest ranges of applications serviced by any one type of plastic material. **Various construction options (wire or braid reinforcement, rigid pipe, unreinforced) and the different formulations available (Industrial, 3A, USDA, FDA, NSF) make PVC attractive for many applications.**

Reinforced suction hose is widely used throughout industry for **both positive and negative pressure** applications. Its advanced design allows the use of **lightweight, corrosion resistant PVC** to replace bulkier, heavier ply-wrapped rubber hose.

**RF-SD, RF-HD and RF-LD are clear, allowing full visual contact with the flow of material inside.** The Food Grade lines are made from FDA-approved ingredients suitable for food and beverage handling. **The smooth interior is easily cleaned and sterilized.** Both types have a vacuum rating of 28 in./Hg. RF-LD is produced from a clear FDA core with and industrial grade white helix, which is not exposed to the hose I.D. It can handle light-duty pressure discharge, gravity feed, and moderate vacuum applications.

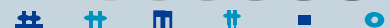

Rubberfab Mold & Gasket • Limecrest Road  
P.O. Box 626 • Andover, NJ 07821  
phone: 973-579-2959 fax: 973-579-7275

[www.rubberfab.com](http://www.rubberfab.com)

Rubberfab Mold & Gasket is a member of:



# RF-PU-ES RF-PU-ET

## Clear Polyurethane Tubing

### Physical Properties\*

	ES	ET
Hardness, Shore A $\pm 5$	85	85
Tensile Strength, psi	6000	5500
Elongation at Break, %	550	580
Brittle Temperature, °F	-95	-90
Max. Op.Temp., °F	185	175

\* Values listed are typical and are meant only as a guide to aid in design. Field testing should be performed to find the actual values for your application.

## ES: Clear Ester formulated Polyurethane Tubing

## ET: Clear Ether formulated Polyurethane Tubing

- Metering Pumps
- Robotics
- Computer Disc Drive Equipment
- Insulating Sleeves
- Small Motor fuel Lines
- Vacuum Equipment
- Pressure Measuring Devices
- Oxygen and Gas Lines
- Nuclear Power Facility Uses
- Transfer Lines for Clean Liquids
- Instrumentation
- Pneumatic Control Systems
- Hydraulic Control Systems
- Automotives
- Fluid Circuitry
- Sensing Systems
- Grease & Lubrication Lines
- Automated Machinery
- Fluid Feeds
- Air Tools
- Oil & Fuel Lines
- Cement Slurries
- Petroleum Products Transfer
- Abrasive Powder Transfer
- Lubricated Air Feeds
- Well Pipe & Cable Jacket
- Granular Transfer
- Agriculture
- And More

- Available in both Ester and Ether formulations
- Clear, flexible, resilient, tough; resistant to oils, greases and fuels
- Resistant to weathering, tearing, impact, radiation and abrasion
- RF-PU-ES has a wide range of temperature resistance: -95°F to 185°F
- Contains no plasticizer that can cause flow contamination or tube hardening
- Can be heat sealed, coiled, fabricated or bonded
- 100% incinerable RF-PU-ET is approved by Scientific Ecology Group (S.E.G.) for the transfer of contaminated and clean liquids

**RF-PU-ET is recommended for hydrolytic stability** (resistance to moisture and fungus). Approved by the National Sanitation Foundation (NSF 51), **RF-PU-ET also resists attack from ultraviolet rays, making it a good material for outside use.** (Note: Ester polyurethane does not react well with water, prolonged humid conditions, or attack from fungus.)

RF-PU is **more resistant to pressure and vacuum applications than corresponding sizes of PVC or rubber.** When used with Thermobarb fittings or Snapflex barbed fittings, RF-PU will not require clamps, provided that working pressures remain at or below 105 psi at ambient temperature.

**Combining good chemical resistance with excellent weathering characteristics** sets polyurethane apart from most other thermoplastics. It has **exceptional resistance to most gasolines, oils, kerosene, and other petroleum-based chemicals, making it an ideal choice for fuel lines** (although some additives in today's gasoline and petroleum products warrant field testing).

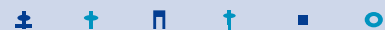

Rubberfab Mold & Gasket • Limecrest Road  
P.O. Box 626 • Andover, NJ 07821  
phone: 973-579-2959 fax: 973-579-7275

[www.rubberfab.com](http://www.rubberfab.com)

Rubberfab Mold & Gasket is a member of:



# RF-PU-ES RF-PU-ET

## Clear Polyurethane Tubing

### RF-PU

ID (IN.)	OD (IN.)	STANDARD LENGTH (FT.)	WORKING PSI AT 70°F	BURST PSI AT 70°F	LBS. PER 100 FT. ESTER	LBS. PER 100 FT. ETHER	PART NO. ESTER	PART NO. ETHER
1/16	1/8	100, 5000	134	402	.48	.45	RF220075	RF230070
1/16	1/8	500	134	402		.45		RF230070
1/8	3/16	100	72	216	.79	.74	RF220152	RF230147
1/8	3/16	3000	72	216	.79		RF220152	
1/8	1/4	100, 1500	133	399	1.92	1.77	RF220229	RF230224
1/8	1/4	1000	133	399		1.77		RF230224
.170	1/4	500	70	210	1.37		RF220383	
3/16	1/4	100, 1500	27	81	1.13		RF220460	
3/16	5/16	100	74	222	2.55	2.38	RF220537	RF230455
3/16	5/16	1000	74	222		2.38		RF230455
1/4	5/16	100	33	99	1.42	1.33	RF220768	RF230609
1/4	3/8	100, 1000	67	201	3.19	2.98	RF220845	RF230686
1/4	1/2	100	131	393	7.66	7.15	RF220999	RF230840
1/4	1/2	500	131	393	7.66		RF220999	
5/16	7/16	100	65	195	3.83	3.57	RF221076	RF230917
5/16	1/2	100	75	225	6.24	5.82	RF221153	RF230994*
5/16	9/16	100	118	354	8.93		RF221230	
3/8	1/2	100	59	177	4.47	4.17	RF221307	RF231148
3/8	1/2	500	59	177		4.17		RF231148
3/8	9/16	100	84	252	7.16	6.68	RF221384	RF231225
3/8	5/8	100	100	300	10.22	9.54	RF221461	RF231302
3/8	5/8	300	100	300	10.22		RF221461	
7/16	11/16	100	80	240	11.48		RF221615	
1/2	5/8	50	36	108		5.36		RF231533
1/2	5/8	100	36	108	5.75	5.36	RF221692	RF231533
1/2	5/8	300	36	108	5.75		RF221692	
1/2	11/16	50, 100	48	144	9.07	8.47		RF231610
1/2	3/4	50, 100	60	180	12.77	11.92	RF221769*	RF231687
5/8	3/4	50, 100	40	120		6.56	RF221846	RF231764
5/8	13/16	50, 100	54	162	10.98	10.25		RF231841
5/8	7/8	50, 100	60	180	15.33	14.30	RF222000	RF231918
3/4	15/16	50, 100	43	129	12.89	12.03	RF222077	RF231995
3/4	1	50, 100	51	153	17.88	16.69		RF232072
7/8	1-1/8	50, 100	33	99	20.43	19.07	RF222231	RF232226
1	1-1/4	50, 100	40	120	22.99	21.46	RF222385	RF232380
1-1/2	1-3/4	25, 50, 100	31	93		30.99	RF222539	RF232534
2	2-1/4	25, 50	22	66		40.53		RF232688

\*Limited stock item; lead times and minimums may apply — call for details.  
 Superthane ET material is NSF approved.  
 Cut coils are available from coils of 100 ft. or less; charges apply — call for details.  
 Coils over 100 ft. are sold by standard coil length only.  
 Tolerances: ID & OD  $\pm 3\%$  but not less than  $\pm .006"$ .

**ES:** Clear Ester formulated Polyurethane Tubing

**ET:** Clear Ether formulated Polyurethane Tubing



Rubber Fab Mold & Gasket • Limecrest Road  
 P.O. Box 626 • Andover, NJ 07821  
 phone: 973-579-2959 fax: 973-579-7275

[www.rubberfab.com](http://www.rubberfab.com)

# RF-TPR

## Thermoplastic Rubber Tubing

### RF-TPR – Natural FDA 64A Durometer

ID (IN.)	OD (IN.)	STANDARD LENGTH (FT.)	LBS. PER 100 FT.	PART NO.
1/8	1/4	50	1.55	RF250246
3/16	5/16	50	2.06	RF250414
1/4	3/8	50	1.15	RF250582
1/4	1/2	50	6.19	RF250638
5/16	7/16	50	3.09	RF250694
3/8	1/2	50	3.61	RF250862
3/8	5/8	50	8.26	RF250974
1/2	5/8	50	4.65	RF251198
1/2	3/4	50	10.32	RF251310
5/8	7/8	50	12.39	RF251646
3/4	1	50	14.45	RF251926

### RF-TPR – Natural FDA 80A Durometer

ID (IN.)	OD (IN.)	STANDARD LENGTH (FT.)	LBS. PER 100 FT.	PART NO.
1/8	1/4	50	1.55	RF256014
3/16	5/16	50	2.06	RF256182
1/4	3/8	50	1.15	RF256350
1/4	1/2	50	6.19	RF256406
5/16	7/16	50	3.09	RF256462
3/8	1/2	50	3.61	RF256630
3/8	5/8	50	8.26	RF256742
1/2	5/8	50	4.65	RF256966
1/2	3/4	50	10.32	RF257078
5/8	7/8	50	12.39	RF257414
3/4	1	50	14.45	RF257638

### RF-TPR – Black Industrial 64A Durometer

ID (IN.)	OD (IN.)	STANDARD LENGTH (FT.)	LBS. PER 100 FT.	PART NO.
1/8	1/4	50	1.55	RF250228
3/16	5/16	50	2.06	RF250396
1/4	3/8	50	1.15	RF250564
1/4	1/2	50	6.19	RF250620
5/16	7/16	50	3.09	RF250676
3/8	1/2	50	3.61	RF250844
3/8	5/8	50	8.26	RF250956
1/2	5/8	50	4.65	RF251150
1/2	3/4	50	10.32	RF251292
5/8	7/8	50	12.39	RF251628
3/4	1	50	14.45	RF251852

### Physical Properties\*

\* Values listed are typical and are meant only as a guide to aid in design. Field testing should be performed to find the actual values for your application.

^ Minimum Recommended Operating Temperature for TPR is -60°F and the Maximum Recommended Operating Temperature is 275°F

Hardness, Shore A @ 77°F, ±5  
Tensile Strength @ 77°F, psi  
Elongation at Break, %  
Tear Strength @ 77°F, %  
Compression Set % @  
77°F after 22 hrs.  
212°F after 22 hrs.  
Brittle Temperature, °F^

Natural FDA 64A	Natural FDA 80A	Black Ind. 64A
64	80	64
1000	1600	1000
400	450	400
10	20	10
22	27	22
34	39	34
<-76	-81	<-76

- Made of **first-quality, polypropylene-based, thermoplastic rubber (RF-TPR)**
- **Outstanding compression characteristics and toughness for peristaltic pump uses**
- **Flexible to temperatures approaching -80°F**
- **Available in both FDA & industrial grades**
- Natural 80A material is listed by the National Sanitation Foundation (NSF-51)\*

**Thermoplastic rubber combines the processability of plastics with the flexibility and durability of rubbers, while more light weight and formable.**

RF-TPR offers **excellent resistance to flex fatigue and tearing**, making it an **ideal choice for peristaltic pump applications**. The FDA material is suitable for a variety of clean uses and is autoclavable to ensure cleanliness.

RF-TPR is now offered in two grades to meet specific applications. FDA grade may be selected from two available durometers — **64A or 80 A** — to meet specific user requirements.

**Black industrial-grade 64A RF-TPR offers good resistance to U.V., ozone, chemicals, and other fluids.** It is well suited for outdoor use, and handles applications where oil may splash onto the tubing.

\*Other durometers with and NSF listing are available as a custom item (please call for details).



Rubberfab Mold & Gasket • Limecrest Road  
P.O. Box 626 • Andover, NJ 07821  
phone: 973-579-2959 fax: 973-579-7275

[www.rubberfab.com](http://www.rubberfab.com)

Rubberfab Mold & Gasket is a member of:



# RF-FKM

## Flexible FKM Tubing

### RF-FKM

ID (IN.)	OD (IN.)	WALL (IN.)	STD. LENGTH (FT.)	PART NO. 60A	PART NO. 75A
1/32	3/32	1/32	100	RF260 0185	RF260 0192
1/32	5/32	1/16	100	RF260 0360*	RF260 0367*
1/16	1/8	1/32	100	RF260 0535	RF260 0542
1/16	3/16	1/16	100	RF260 0710	RF260 0717*
1/16	1/4	3/32	100	RF260 0885	RF260 0892*
1/8	1/4	1/16	100	RF260 1235	RF260 1242
1/8	5/16	3/32	100	RF260 1410	RF260 1417*
1/8	3/8	1/8	100	RF260 1585*	RF260 1592*
3/16	5/16	1/16	100	RF260 1935	RF260 1942
3/16	7/16	1/8	50	RF260 2110	RF260 2117*
1/4	3/8	1/16	50	RF260 2810	RF260 2817
1/4	7/16	3/32	50	RF260 2985	RF260 2992*
1/4	1/2	1/8	50	RF260 3160	RF260 3167*
1/4	9/16	5/32	50	RF260 3335	RF260 3342*
5/16	7/16	1/16	50	RF260 3685	RF260 3692
3/8	1/2	1/16	50	RF260 3860	RF260 3867
3/8	9/16	3/32	25	RF260 4035	RF260 4042*
3/8	5/8	1/8	25	RF260 4210	RF260 4217
1/2	5/8	1/16	25	RF260 4560	RF260 4567*
1/2	3/4	1/8	25	RF260 4910	RF260 4917
1/2	7/8	3/16	25	RF260 5085*	RF260 5092
5/8	1	3/16	25	RF260 5785	RF260 5792*
3/4	1	1/8	25	RF260 5960	RF260 5967
7/8	1	1/16	25	RF260 6135	RF260 6142*

\*Limited stock item; lead times and minimums may apply — call for details.

### Physical Properties\*

Hardness, Shore A $\pm 5$	60	75
Tensile Strength, psi	1450	1600
Elongation at Break, %	350	150
Brittle Temperature, °F	-40	-30
Max. Operating Temp., °F	400	400

\* Values listed are typical and are meant only as a guide to aid in design. Field testing should be performed to find the actual values for your application.

### Tolerances

0" - .100"	$\pm .010$
.101" - .160"	$\pm .013$
.161" - .250"	$\pm .016$
.251" - .400"	$\pm .020$
.401" - .630"	$\pm .025$
.631" -1.000"	$\pm .032$

- A **high performance synthetic rubber**
- **Excellent temperature resistance:** -40°F to 400°F continuously; 600°F periodically
- Offers one of the **widest ranges of fluid and chemical resistance** of any commercial rubber
- **Excellent resistance to oils, fuels, lubricants, and most mineral acids**
- **Also resistant to many aliphatic and aromatic hydrocarbons such as carbon tetrachloride, benzene, toluene, and xylene**
- **Excellent resistance to environmental exposure such as sunlight and ozone**
- Available in 60 and 75 Shore A durometers

RF-FKM's main attributes include **exceptional chemical resistance at elevated temperatures**. It has withstood continuous service temperatures of 600°F for 48 hours and 500°F for 1000 hours while maintaining its mechanical properties. Care should be taken, however, at these elevated temperatures. Tests should be performed to determine suitability.

RF-FKM **possesses the high resiliency of an elastomer as well as the good mechanical properties of conventional synthetic rubbers**. The heat and chemical resistance factors, however, usually go far beyond the range of other rubbers.

The 60A durometer compound is specially formulated for use in peristaltic pumps. All RF-FKM formulations are produced with 100% DuPont Dow Viton fluoroelastomers and are matte black in color. RF-FKM contains no regrind material or blends of other elastomers.

If accidental burning of RF-FKM occurs, extreme caution should be taken due to Hydrogen Fluoride and other decomposition products. Avoid inhalation of vapors liberated at service temperatures above 400F.



Rubberfab Mold & Gasket • Limecrest Road  
P.O. Box 626 • Andover, NJ 07821  
phone: 973-579-2959 fax: 973-579-7275

[www.rubberfab.com](http://www.rubberfab.com)

Rubberfab Mold & Gasket is a member of:



# RF-NY-R RF-NY-F

## Nylon-12 Semi Rigid and Flexible Grade Tubing

### Physical Properties\*

	Semi-Rigid Grade	Flexible Grade
Hardness, Shore A $\pm 5$	72	63
Tensile Strength, psi	7790	7348
Elongation at Break, %	300	300
Brittle Temperature, °F	<-90	<-90
Max. Operating Temp., °F	212	212

\* Values listed are typical and are meant only as a guide to aid in design. Field testing should be performed to find the actual values for your application.

### Tolerances

OD (INCH)	TOLERANCE (INCH)
1/8 - 5/32	+ .001, - .003
3/16 - 5/8	+ .001, - .004
3/4	+ .001, - .005
1	+ .001, - .006

OD (MM)	TOLERANCE (MM)
4	+ .0254, - .0762
5 - 12	+ .0254, - .1000

- Compressed Air
- Instrumentation
- Grease Lines
- Fuel and Oil Transfer
- Dispensing Equipment
- Automobiles
- Refrigeration & Cooling Systems
- Appliances
- Hydraulic Lines
- Laboratories

- Chemical Transfer
- Air Conditioning Systems
- Food & Beverage (with FDA Grade)
- Paint Supply
- Housewares
- Manufacturing Equipment
- Pneumatic Controls
- Well Pumps
- And More

- **Very low moisture absorption**  
1.9% maximum at 73°F
- **Will not become brittle or swell when exposed to water**
- **Excellent resistance to flexural fatigue, tube vibration, and movement**
- **Lightweight, with excellent bend radii and pressure ratings**
- **Resists abrasion, crushing, and cracking**
- **Standard availability in metric sizes and colors**
- **Tightest tolerances** available (see chart)
- **100% incineration-approved** by Scientific Ecology Group (S.E.G.)
- **Semi-Rigid grade, black, is heat and light stabilized**

Aimed as a **substitute for metal**, nylon's light weight and its **resistance to corrosion and abrasion** have made it an attractive design choice.

RF-NY-R and RF-NY-F are now offered in the **nylon-12 formulation for a lower cost with virtually the same physical properties and performance as nylon-11**. Nylon's elastic memory can **withstand repeated flexing** over a long period of time without fatigue or fracture.

Further, RF-NY-R and RF-NY-F offer **high-impact resistance**, even at **subfreezing temperatures, and low moisture absorption**. While nylon brittleness can occur through cycles of water absorption and depletion, RF-NY-R and RF-NY-F **are not dependent on moisture for flexibility**. Their **life expectancy is greatly increased and brittleness is eliminated**. RF-NY-R and RF-NY-F are **resistant to solvents, alkalies, oils, greases, petroleum products, fungus, and molds**. These products have good **resistance to diluted mineral and organic acids**, but in-plant tests are suggested.



Rubberfab Mold & Gasket • Limecrest Road  
P.O. Box 626 • Andover, NJ 07821  
phone: 973-579-2959 fax: 973-579-7275

[www.rubberfab.com](http://www.rubberfab.com)

Rubberfab Mold & Gasket is a member of:



# RF-NY-R RF-NY-F

## Nylon-12 Semi Rigid and Flexible Grade Tubing

### RF-NY-R – Semi-rigid Grade

ID (IN.)	OD (IN.)	STANDARD LENGTH (FT.)	WORKING PSI AT 70°F	BURST PSI AT 70°F	BEND RADIUS* (IN.)	LBS. PER 100 FT.	PART NO. NATURAL	PART NO. BLACK
.095	1/8	500	435	1740	3/8	.25	RF370580	RF370531
.075	1/8	500	805	3220	1/4	.35	RF370265	RF370216
.106	5/32	250	610	2440	3/8	.47	RF371210	RF371161
.086	5/32	250	925	3700	1/4	.60	RF370895	RF370846
.137	3/16	250	500	2000	1/2	.58	RF371840	RF371791
.107	3/16	250	875	3500	3/8	.84	RF371525	RF371476
.190	1/4	100, 250	455	1820	1	.95	RF372470	RF372421
.150	1/4	250	805	3220	1/2	1.39	RF372155	RF372106
.242	5/16	100	405	1620	1-1/4	1.35	RF373100	RF373051
.182	5/16	100	845	3380	7/8	2.20	RF372785	RF372736
.295	3/8	100	385	1540	1-1/2	1.92	RF373730	RF373681
.225	3/8	100	805	3220	1	3.20	RF373415	RF373366

\*Use only as a guide.

### RF-NY-F – Flexible Grade

ID (IN.)	OD (IN.)	STD LGTH (FT.)	WORK. PSI AT 70°F	BURST PSI AT 70°F	BEND RADIUS* (IN.)	LBS. PER 100 FT.	PART NO. NATURAL	PART NO. BLACK	PART NO. RED^	PART NO. YELLOW^	PART NO. GREEN^	PART NO. BLUE^
.058	1/8	500	725	2900	5/16	.44	RF360261	RF360212	RF360289	RF360310	RF360254	RF360219
.117	3/16	250	455	1820	3/8	.74	RF360576	RF360527	RF360604	RF360625	RF360569	RF360534
.170	1/4	250	375	1500	1/2	1.15	RF360891	RF360842	RF360919	RF360940	RF360884	RF360849
1/4	3/8	100	400	1600	1	2.69	RF361521	RF361472	RF361549	RF361570	RF361514	RF361479
3/8	1/2	100	285	1140	1-1/2	3.88	RF361836	RF361787	RF361864	RF361885	RF361829	RF361794
1/2	5/8	100	220	880	2-1/2	15.21	RF362151	RF362102				
19/32	3/4	100	225	900	4	7.36	RF362466	RF362417				
13/16	1	100	205	820	7	11.74	RF362781	RF362732				

\*Use only as a guide.

^Red, Yellow, Green, and Blue are available in 100 ft. coils only.

### RF-NY-F – Metric Sizes, Flexible Grade

ID (MM)	OD (MM)	WORKING PSI AT 70°F	BURST PSI AT 70°F	BEND RADIUS* (MM)	LBS. PER 100 FT.	PART NO. NATURAL	PART NO. BLACK	PART NO. RED	PART NO. YELLOW	PART NO. GREEN	PART NO. BLUE
2.5	4	415	1660	8	.53	RF360267	RF360211	RF360295	RF360309	RF360253	RF360225
4.0	6	358	1432	13	1.06	RF360897	RF360841	RF360925	RF360939	RF360883	RF360855
6.0	8	255	1020	32	1.49	RF361212	RF361156	RF361240	RF361254	RF361198	RF361170
8.0	10	200	800	50	2.00	RF361527	RF361471	RF361555	RF361569	RF361513	RF361484
9.0	12	257	1028	45	3.32	RF361842	RF361786	RF361877	RF361884	RF361828	RF361800

\*Use only as a guide.

All tubing sold by standard coil length only (100 ft.).

Metric fittings are available from stock.



Rubber Fab Mold & Gasket • Limecrest Road  
P.O. Box 626 • Andover, NJ 07821  
phone: 973-579-2959 fax: 973-579-7275

[www.rubberfab.com](http://www.rubberfab.com)

# RF-CHEM

## Chemical and Petrochemical Transfer Tubing

### RF-CHEM

ID	OD	STOCK NO.	WALL	LENGTH	LBS./FT.	MAX. WKG. PSI AT 73 F		PART NO.
3/32	5/32	GO1	1/32	50'	0.007	42	0.0420	RF45901805
1/8	1/4	GO2	1/16	100'	0.019	68	0.1540	RF4502*
1/8	1/4	GO2	1/16	50'	0.019	68	0.1540	RF450205
3/16	5/16	GO3	1/16	100'	0.028	55	0.2000	RF4503
3/16	5/16	GO3	1/16	50'	0.028	55	0.2000	RF450305
1/4	3/8	GO6	1/16	100'	0.032	55	0.2540	RF4506
1/4	3/8	GO6	1/16	50'	0.032	55	0.2540	RF450605
5/16	7/16	GO9	1/16	50'	0.040	50	0.3060	RF450905
3/8	1/2	GO12	1/16	100'	0.045	40	0.3560	RF4512*
3/8	1/2	GO12	1/16	50'	0.045	40	0.3560	RF451205
7/16	9/16	GO15	1/16	50'	0.053	40	0.4840	RF451505
1/2	5/8	GO18	1/16	50'	0.060	30	0.6132	RF451805
1/2	3/4	GO20	1/8	100'	0.128	45	1.0200	RF4520
1/2	3/4	GO20	1/8	50'	0.128	45	1.0200	RF452005
5/8	7/8	GO26	1/8	50'	0.160	40	1.6084	RF452605
3/4	1	GO31	1/8	50'	0.186	35	1.8496	RF453105

### Physical Properties\*

Hardness, Shore A	62
Tensile Strength, psi	1980
Elongation at Break, %	730
Brittle Temperature, °F	-20.2
Specific Gravity	1.25

\* Values listed are typical and are meant only as a guide to aid in design. Field testing should be performed to find the actual values for your application.

- For use in the transfer of chemicals and petrochemicals including: gasoline, kerosene, oils and cutting compounds
- Specifically formulated to resist hardening and swelling
- Transparent and flexible
- Protects against leaching and product contamination

**RF-CHEM is not to be used in contact with food, beverage or drugs.**

**Transparent yellow RF-CHEM is stocked in the twelve sizes necessary to supply applications involving gas and oil.**



Rubberfab Mold & Gasket • Limecrest Road  
P.O. Box 626 • Andover, NJ 07821  
phone: 973-579-2959 fax: 973-579-7275

[www.rubberfab.com](http://www.rubberfab.com)

Rubberfab Mold & Gasket is a member of:



# RF-PE

## Polyethylene Tubing

- Produced from 100% virgin, low-density polyethylene resin
- Seven brilliant hues: red, yellow, orange, green, blue, black and white
- Superior working pressure
- Excellent metal tubing alternative
- Strippable, siamese and multiple-bore configurations available

### RF-PE

ID	OD	SIZE NO.	WALL	COLOR	LGTH	WKG. PSI AT 73°F	COILS/ BOX	APPROX. LBS./FT.	PART NO.
0.170	1/4	1	0.040	NATURAL	500'	135	4	0.0105	RF510150
0.170	1/4	1	0.040	BLACK	500'	135	4	0.0105	RF5101501
0.170	1/4	1	0.040	BLUE	500'	135	4	0.0105	RF5101502
0.170	1/4	1	0.040	GREEN	500'	135	4	0.0105	RF5101504
0.170	1/4	1	0.040	ORANGE	500'	135	4	0.0105	RF5101505*
0.170	1/4	1	0.040	RED	500'	135	4	0.0105	RF5101507
0.170	1/4	1	0.040	WHITE	500'	135	4	0.0105	RF5101508*
0.170	1/4	1	0.040	YELLOW	500'	135	4	0.0105	RF5101509
1/8	1/4	2	1/16	NATURAL	100'	180	10	0.0147	RF510210
1/8	1/4	2	1/16	NATURAL	500'	180	4	0.0147	RF510250
1/8	1/4	2	1/16	BLACK	500'	180	4	0.0147	RF5102501*
3/16	5/16	3	1/16	NATURAL	100'	140	10	0.0196	RF510310
3/16	5/16	3	1/16	NATURAL	500'	140	4	0.0196	RF510350
3/16	5/16	3	1/16	BLACK	500'	140	4	0.0196	RF5103501*
1/4	3/8	6	1/16	NATURAL	100'	120	7	0.0245	RF510610
1/4	3/8	6	1/16	NATURAL	500'	120	2	0.0245	RF510650
1/4	3/8	6	1/16	BLACK	500'	120	2	0.0245	RF5106501
1/4	3/8	6	1/16	BLUE	500'	120	2	0.0245	RF5106502
1/4	3/8	6	1/16	GREEN	500'	120	2	0.0245	RF5106504
1/4	3/8	6	1/16	ORANGE	500'	120	2	0.0245	RF5106505*
1/4	3/8	6	1/16	RED	500'	120	2	0.0245	RF5106507
1/4	3/8	6	1/16	WHITE	500'	120	2	0.0245	RF5106508*
1/4	3/8	6	1/16	YELLOW	500'	120	2	0.0245	RF5106509
5/16	7/16	6A	1/16	NATURAL	100'	68	10	0.0110	RF5106710*
5/16	7/16	9	1/16	NATURAL	100'	103	5	0.0294	RF510910*
5/16	7/16	9	1/16	NATURAL	500'	103	2	0.0294	RF510950*
3/8	1/2	12	1/16	NATURAL	100'	90	5	0.0343	RF511210
3/8	1/2	12	1/16	NATURAL	500'	90	2	0.0343	RF511250
3/8	1/2	12	1/16	BLACK	500'	90	2	0.0343	RF5112501
3/8	1/2	12	1/16	ORANGE	500'	90	2	0.0343	RF5112505*
3/8	1/2	12	1/16	WHITE	500'	90	2	0.0343	RF5112508*
3/8	1/2	12	1/16	YELLOW	500'	90	2	0.0343	RF5112509
1/2	5/8	18	1/16	NATURAL	100'	70	4	0.0441	RF511810
1/2	5/8	18	1/16	BLACK	100'	70	4	0.0441	RF5118101
5/8	3/4	24A	1/16	NATURAL	100'	60	2	0.0539	RF5124101
5/8	3/4	24A	1/16	BLACK	100'	60	2	0.0539	RF5124102*
5/8	13/16	25	3/32	NATURAL	100'	82	2	0.0845	RF512510*
5/8	7/8	26A	1/8	NATURAL	100'	100	1	0.1176	RF5126101*
3/4	1	31	1/8	NATURAL	100'	90	1	0.1372	RF513110
7/8	1	31B	1/16	NATURAL	100'	45	1	0.0735	RF5131101
1	1-1/4	35	1/8	NATURAL	100'	72	1	0.1764	RF513510
1-1/4	1-1/2	38A	1/8	NATURAL	50'	59	1	0.2156	RF5138050
1-1/2	1-3/4	39B	1/8	NATURAL	50'	50	1	0.2548	RF5139052
2	2-1/4	42A	1/8	NATURAL	50'	39	1	0.3332	RF5142051*

RF-PE is a **chemically inert, non-contaminating translucent tube that meets FDA standards**, making it an ideal choice for laboratory, hospital, food and beverage applications.

RF-PE's **exceptional stability, long life and resistance to corrosion** makes it well suited for use with pneumatic controls, instrumentation and hydraulic applications.

**Seven brilliant hues: red, yellow, orange, green, blue, black and white**, plus a natural translucent grade, give system designers a wide selection of **color coding for easy circuit traceability and identification**.

RF-PE is **available in strippable, siamese and multiple-bore configurations** which reduce installation time and encourage the production of neat layouts in multiline systems.

RF-PE can be **custom formulated for electrical conductive properties, weather or fungus resistance**.

RF-PE is also available as a **coextruded liner material in applications where additional flexibility is required without sacrificing inertness**.

### Physical Properties\*

	PE
Hardness, Shore A	1600
Tensile Strength, psi	500
Elongation at Break, %	-76
Brittle Temperature, °F	.921
Density	

\* Values listed are typical and are meant only as a guide to aid in design. Field testing should be performed to find the actual values for your application.

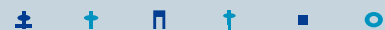

Rubberfab Mold & Gasket • Limecrest Road  
P.O. Box 626 • Andover, NJ 07821  
phone: 973-579-2959 fax: 973-579-7275

[www.rubberfab.com](http://www.rubberfab.com)

Rubberfab Mold & Gasket is a member of:



# CONVOLUTED PTFE HOSE

RF-CTLP  
RF-CTLPB  
RF-CTLPP  
RF-CTLPPB

Rubber Fab convoluted PTFE hoses offer a non-stick, helically-shaped inner core which minimizes pressure drops and simplifies cleaning. These flexible hoses are designed to transport almost all substances and to withstand the most demanding conditions, including high velocity and pressure surges. The standard PTFE inner core can be replaced with an optional black non-conductive liner. All are available in bulk or fabricated assemblies.

## RF-CTLP – Convoluted Low-Profile PTFE Lined Hose with Braided Stainless Steel Cover



**TUBE:**  
Seamless White  
Convoluted PTFE

**COVER:**  
Braided Stainless  
Steel

**TEMPERATURE:**  
-100°F to 450°F

Part Number	I.D.	O.D.	Working Pressure*	Vacuum (In. Hg)	Bend Radius
08RFCTLP	.50	.750	500 psi	29.9	1.75"
12RFCTLP	.75	1.125	425 psi	29.9	2.25"
16RFCTLP	1.0	1.313	350 psi	29.9	2.75"
24RFCTLP	1.5	1.90	275 psi	29.9	3.75"
32RFCTLP	2.0	2.425	250 psi	5.0	6.5"
48RFCTLP	3.0	3.7	175 psi	5.0	10.0"
64RFCTLP	4.0	5.0	150 psi	5.0	12.0"

\*at 68°F

## RF-CTLPB – Convoluted Low Profile Black Conductive PTFE Lined Hose with Braided Stainless Steel Cover

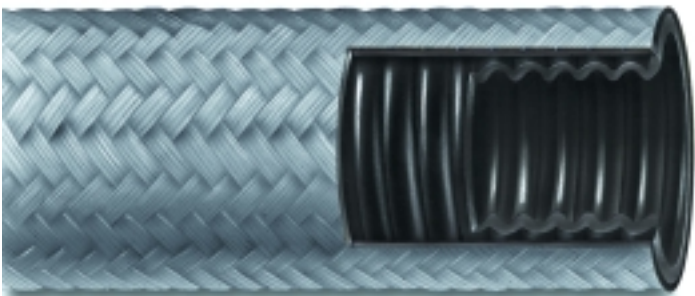

**TUBE:**  
Seamless Black  
Conductive  
Convoluted PTFE

**COVER:**  
Braided Stainless  
Steel

**TEMPERATURE:**  
-100°F to 450°F

Part Number	I.D.	O.D.	Working Pressure*	Vacuum (In. Hg)	Bend Radius
08RFCTLPB	.50	.750	500 psi	29.9	1.75"
12RFCTLPB	.75	1.125	425 psi	29.9	2.25"
16RFCTLPB	1.0	1.313	350 psi	29.9	2.75"
24RFCTLPB	1.5	1.90	275 psi	29.9	3.75"
32RFCTLPB	2.0	2.425	250 psi	5.0	6.5"
48RFCTLPB	3.0	3.7	175 psi	5.0	10.0"
64RFCTLPB	4.0	5.0	150 psi	5.0	12.0"

\*at 68°F



## RF-CTLPP – Convoluted Low Profile PTFE Lined Hose with Braided Polypropylene Cover



**TUBE:**  
Seamless White PTFE

**COVER:**  
Braided Blue Polypropylene

**TEMPERATURE:**  
-40°F to 250°F

Part Number	I.D.	O.D.	Working Pressure*	Weight Per Foot	Vacuum (In. Hg)	Bend Radius
08RFCTLPP	.50	.950	250 psi	.120	29.9	1.75"
12RFCTLPP	.75	1.27	250 psi	.250	25	2.25"
16RFCTLPP	1.0	1.55	250 psi	.300	22	2.75"
24RFCTLPP	1.5	2.01	200 psi	.530	14	7.0"
32RFCTLPP	2.0	2.55	200 psi	.900	5.0	9.0"
48RFCTLPP	3.0	3.75	200 psi	1.42	5.0	10"

\*at 68°F

## RF-CTLPPB – Convoluted Low Profile Black Conductive PTFE Lined Hose with Braided Polypropylene Cover

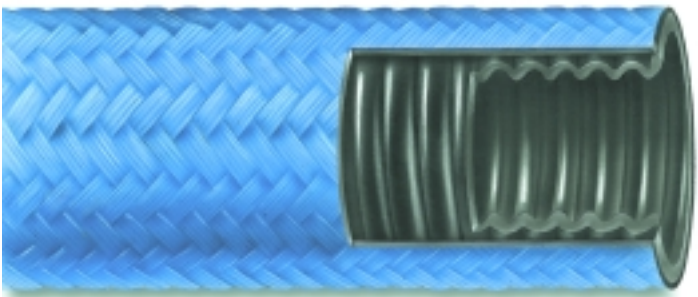

**TUBE:**  
Seamless Black Conductive PTFE

**COVER:**  
Braided Blue Polypropylene

**TEMPERATURE:**  
-40°F to 250°F

Part Number	I.D.	O.D.	Working Pressure*	Weight Per Foot	Vacuum (In. Hg)	Bend Radius
08RFCTLPPB	.50	.950	250 psi	.120	29.9	1.75"
12RFCTLPPB	.75	1.27	250 psi	.250	25	2.25"
16RFCTLPPB	1.0	1.55	250 psi	.300	22	2.75"
24RFCTLPPB	1.5	2.01	200 psi	.530	14	7.0"
32RFCTLPPB	2.0	2.55	200 psi	.900	5.0	9.0"
48RFCTLPPB	3.0	3.75	200 psi	1.42	5.0	10"

\*at 68°F

### Approvals

- 3A Sanitary
- USP Class VI
- FDA 21 CFR 177.1550

### RF-CTLP/RF-CTLPPB Features

- Lower convolutions for minimal pressure drop and ease of cleaning
- Inner core is convoluted non-stick PTFE
- Outer cover is stainless steel braid overwrap
- Non-stick contact surface will not contaminate contacted substances
- Not affected by weather and will not age in service within the recommended temperature and pressure ratings
- Withstands high velocity and pressure surges
- Unaffected by continuous flexing or vibration when used in accordance with minimum bend radius specifications
- Autoclavable and steam-cleanable
- Available in bulk or fabricated assemblies
- Available with carbon conductive liner

### RF-CTLPP/RF-CTLPPB Features

- Inner core is low profile convoluted white PTFE
- Outer cover is bonded with a PTFE fiberglass braid and overbraid with a polypropylene monofilament
- Each monofilament strand is twisted for abrasion and chemical-resistance
- Full vacuum rating on all sizes at 70°F
- Will not conduct internal heat as quickly as metallic braided hoses
- Conveys most all substances and withstands the environmental conditions in which it operates
- Available conductive liner for static dissipation
- Ease of cleanability
- Available in bulk or fabricated assemblies

### Applications

- Food processing
- Pharmaceutical processing
- Cosmetics
- Hot CIP solutions
- Chemical products
- Low pressure steam applications

### Connections

- Broad variety fittings in 316L Stainless Steel, PTFE encapsulated or non-metallic materials
- Electropolished Stainless Steel fittings available
- Crimped fittings available in other high quality alloys
- Available with etched date or purchase order number on crimp collars



± + ▢ ↑ ▣ ○  
Rubber Fab Technologies Group  
Limecrest Road

P.O. Box 626 • Andover, NJ 07821  
phone: 973-579-2959 fax: 973-579-7275

[www.rubberfab.com](http://www.rubberfab.com)

Rubber Fab Technologies Group is a member of:



# FDA PVC HOSE

Rubber Fab FDA PVC hoses are designed to transport a wide variety of fluids without imparting odor or taste. Non-toxic, non-pyrogenic, and alkaline resistant, these features render our hoses ideal for food/beverage, laboratory, and surgical/hospital applications. All are available in bulk or fabricated assemblies.

**RF-PB**  
**RF-PVV**  
**RF-PVW**  
**RF-PC**

## RF-PB – Clear PVC Braided Hose

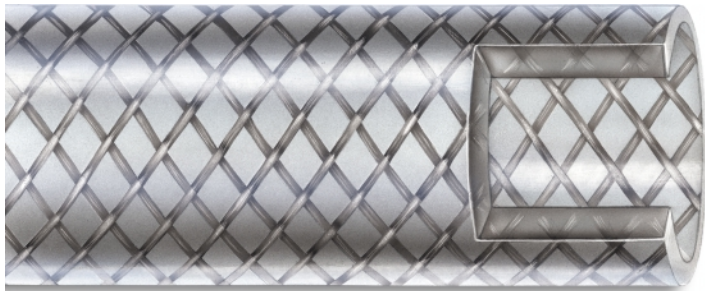

**TUBE:**  
 FDA PVC

**COLOR:**  
 Transparent

**CONSTRUCTION:**  
 Clear with polyester textile inner braid reinforcement

**TEMPERATURE:**  
 -25°F to 150°F

Part Number	I.D.	O.D.	Working Pressure*	Weight Per Foot	Bend Radius
02RFPB	.125	.328	250 psi	.040	
04RFPB	.250	.500	250 psi	.077	
06RFPB	.375	.625	250 psi	.104	
08RFPB	.500	.813	225 psi	.168	5"
10RFPB	.625	1.00	225 psi	.260	
12RFPB	.750	1.13	200 psi	.284	7"
14RFPB	.875	1.16	100 psi	.229	
16RFPB	1.00	1.38	100 psi	.366	9"
18RFPB	1.13	–	100 psi	.522	
24RFPB	1.50	2.00	100 psi	.747	15"

\*at 68°F  
 \*additional sizes available

## RF-PVV – Spiral-Reinforced Hose

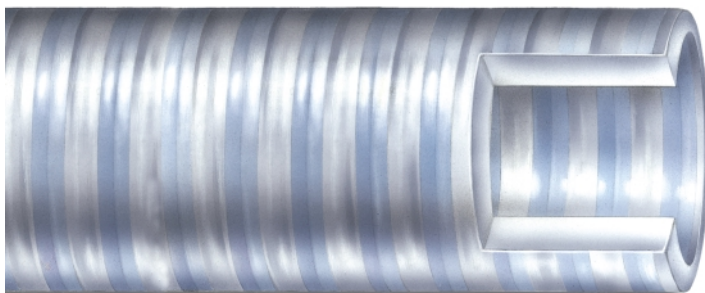

**TUBE:**  
 FDA PVC

**COLOR:**  
 Translucent

**CONSTRUCTION:**  
 Clear extrusion with clear helical reinforcement

**TEMPERATURE:**  
 -25°F to 150°F

Part Number	I.D.	O.D.	Wkg. Pres.*	Weight Per Foot	Vac. Rating	Max. Bend Radius
40RFPVV	2.50	2.88	65	.85	28	10"
48RFPVV	3.00	3.42	65	1.15	28	11"
64RFPVV	4.00	4.56	50	1.75	28	16"
96RFPVV	6.00	6.58	30	3.60	24	48"

\*at 68°F

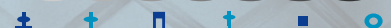

## RF-PVW – Wire-Reinforced Hose

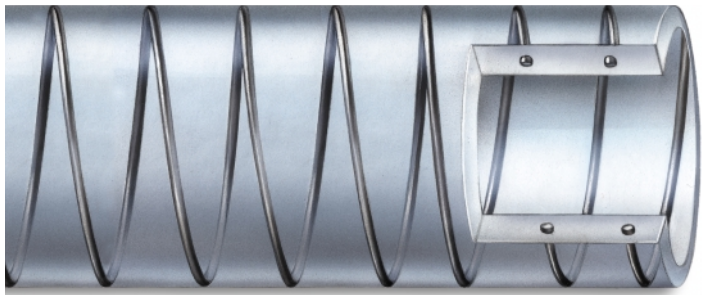

TUBE: FDA PVC	Part Number	I.D.	O.D.	Wkg. Pres.*	Weight Per Foot	Vac. (In. HG)	Max. Bend Radius
COLOR: Transparent	04RFPVW	.250	.500	250 psi	.118	29.9	1.5"
CONSTRUCTION: Clear with steel wire helix wire reinforcement	06RFPVW	.375	.625	100 psi	.125	29.9	1.5"
TEMPERATURE: -25°F to 150°F	08RFPVW	.500	.750	100 psi	.142	29.9	2.0"
	10RFPVW	.625	.875	100 psi	.178	29.9	3.0"
	12RFPVW	.750	1.00	100 psi	.253	29.9	3.0"
	16RFPVW	1.00	1.375	100 psi	.449	29.9	4.0"
	20RFPVW	1.25	1.56	70 psi	.485	29.9	5.0"
	24RFPVW	1.50	1.89	50 psi	.828	29.9	6.0"
	32RFPVW	2.00	2.36	50 psi	1.08	29.9	8.0"

\*at 68°F

## RF-PC – Clear, Non-Reinforced Hose

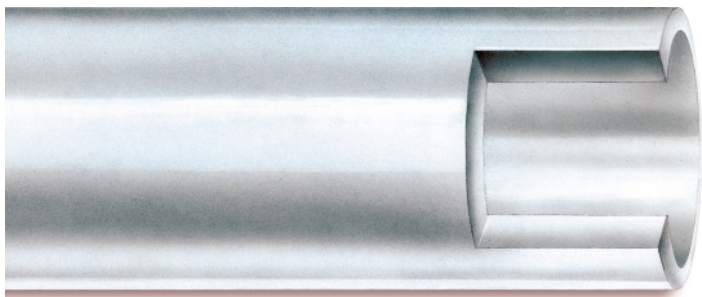

TUBE: FDA PVC	Part Number	I.D.	O.D.	Working Pressure*	Weight Per Foot
COLOR: Transparent	02RFPC	.125	.328	65 psi	.040
CONSTRUCTION: Clear Non-Reinforced	04RFPC	.250	.500	60 psi	.077
TEMPERATURE: -25°F to 150°F	06RFPC	.375	.625	55 psi	.104
	08RFPC	.500	.813	45 psi	.168
	12RFPC	.750	1.13	40 psi	.284
	14RFPC	.875	1.11	30 psi	.229
	16RFPC	1.00	1.36	30 psi	.366
	20RFPC	1.25	1.75	40 psi	.522
	24RFPC	1.50	2.00	35 psi	.747
	32RFPC	2.00	2.50	35 psi	.839

\*at 68°F

\*additional sizes available

## RF-PB RF-PVV RF-PVW RF-PC

### Approvals

- 3A Sanitary Standard 1800
- FDA
- USDA

### Features

- Clear, Flexible
- Imparts no taste or odor
- Non-Toxic
- Non-Pyrogenic
- Alkaline-Resistant
- Available in bulk or fabricated assemblies

### Applications

This family of PVC products includes one of the **widest ranges of applications serviced by any one type of plastic material.** Various construction options (wire, braid or non-metallic reinforced, or non-reinforced) and the different formulations available (Industrial, 3A, USDA, FDA, NSF) make PVC attractive for many applications.

- Chemical Processing & Transfer
- Pharmaceutical Manufacture
- Food & Syrup Handling
- Beverage Transfer
- Dairy Processing
- Air & Gas Lines
- Pump Feed & Discharge
- Laboratory & Research
- Instrumentation
- General Water Suction & Discharge
- Irrigation Systems
- Vacuum Lines
- Hydraulics & Pneumatics
- Spray Systems
- Filters

### Connections

- Sanitary, Unitized Non-Metallic Fittings
- Stainless Steel or Non-Metallic Radially-Crimped Connections



Rubber Fab Technologies Group  
Limecrest Road  
P.O. Box 626 • Andover, NJ 07821  
phone: 973-579-2959 fax: 973-579-7275  
[www.rubberfab.com](http://www.rubberfab.com)

Rubber Fab Technologies Group is a member of:



# FDA RUBBER HOSE

Rubber Fab FDA-approved rubber hoses are designed to transport a wide variety of fluids without imparting odor or taste. These premium, reinforced hoses perform high-quality sanitary suction and/or discharge. Custom laylines are available. Some hoses are available in a variety of colors, and all are available in a variety of sizes, in bulk or fabricated assemblies.

**RF-FDAE**  
**RF-FDA**  
**RF-FDAELF**  
**RF-FDACC**  
**RF-FDAEF**

## RF-FDAE – Food Grade EPDM Suction and Discharge Hose



**TUBE:**

Seamless White EPDM

**COVER:**

Grey EPDM Rubber (Abrasion and oil resistant)

**REINFORCEMENT:**

Two polyester spirals with dual helix wire

**TEMPERATURE:**

-40°F to 300°F

Part Number	I.D.	O.D.	Working Pressure*	Bend Radius
08RFFDAE	.500	.931	150 psi	2.50"
12RFFDAE	.750	1.182	150 psi	3.75"
16RFFDAE	1.00	1.500	150 psi	4.00"
24RFFDAE	1.50	2.09	150 psi	5.00"
32RFFDAE	2.00	2.600	150 psi	6.00"
40RFFDAE	2.50	3.173	150 psi	7.00"
48RFFDAE	3.00	3.718	150 psi	8.00"
64RFFDAE	4.00	4.781	150 psi	11.0"

\*at 68°F

## RF-FDA – Food Grade Nitrile Suction and Discharge Hose



**TUBE:**

Seamless White Nitrile

**COVER:**

White Nitrile Rubber (Abrasion and oil resistant)

**REINFORCEMENT:**

Two polyester spirals with dual helix wire

**TEMPERATURE:**

-40°F to 180°F

Part Number	I.D.	O.D.	Working Pressure*	Bend Radius
08RFFDA	.500	.931	150 psi	2.50"
12RFFDA	.750	1.182	150 psi	3.75"
16RFFDA	1.00	1.50	150 psi	4.00"
24RFFDA	1.50	2.09	150 psi	5.00"
32RFFDA	2.00	2.60	150 psi	6.00"
40RFFDA	2.50	3.173	150 psi	7.00"
48RFFDA	3.00	3.718	150 psi	8.00"
64RFFDA	4.00	4.781	150 psi	11.0"

\*at 68°F



## RF-FDAELF – Food Grade Lay Flat Hose

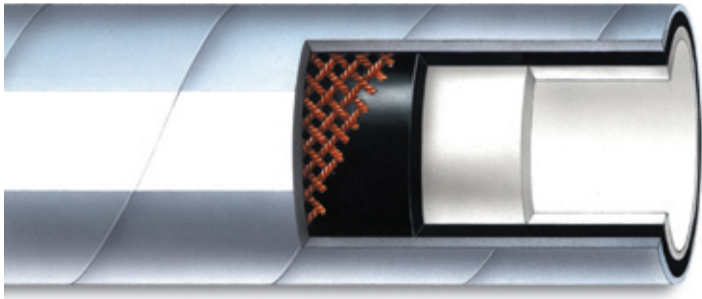

TUBE: White FDA EPDM	Part Number	I.D.	O.D.	Working Pressure*	Weight Per Foot
	16RFFDAELF	1.0	1.340	150 psi	.401
	24RFFDAELF	1.5	1.888	150 psi	.662
	32RFFDAELF	2.0	2.388	150 psi	.859
	40RFFDAELF	2.5	2.885	150 psi	1.06
	48RFFDAELF	3.0	3.388	125 psi	1.25
	64RFFDAELF	4.0	4.388	95 psi	1.65
	96RFFDAELF	6.0	6.388	75 psi	2.06

\*at 68°F

## RF-FDACCRR – FDA Crush Resistant Hose

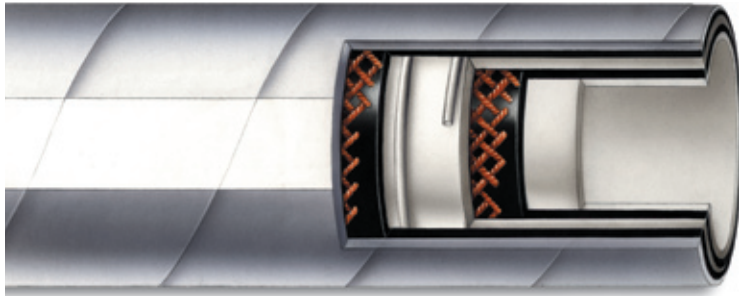

TUBE: White FDA Chlorobutyl	Part Number	I.D.	O.D.	Working Pressure*	Weight Per Foot	Bend Radius
	24RFFDACCRR	1.50	2.25	250 psi	1.16	5.00"
	32RFFDACCRR	2.00	2.78	250 psi	1.52	7.00"
	40RFFDACCRR	2.50	3.28	250 psi	1.93	13.00"
	48RFFDACCRR	3.00	3.78	250 psi	2.27	21.00"
	64RFFDACCRR	4.00	4.78	200 psi	3.03	15.00"

\*at 68°F

## RFFDAEF – Flanged Food Grade EPDM Suction and Discharge Hose

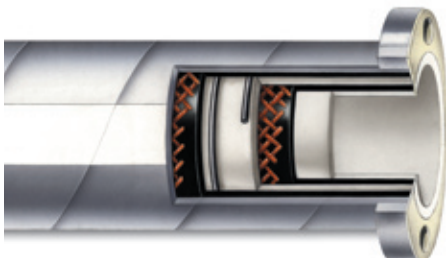

*RF-FDAEF hose is the flanged version of our RF-FDAE food grade suction and discharge hose (front page, top hose). When ordering, simply add an "F" to the end of the RF-FDAE part number.*

## RF-FDAE RF-FDA RF-FDAELF RF-FDACCRR

### Approvals

- 3A Sanitary Standard 1800
- FDA 21 CFR 177.2600
- USDA
- Conforms to the construction criteria of the Grade A Pasteurized Milk Ordinance

### Features

- Custom laylines available
- Smooth inner-bore does not allow for entrapment
- Available in bulk or fabricated assemblies
- Available in 8 different colors
- Contact Rubber Fab for available lengths

### RF-FDAELF – Lay Flat Features

- Tubing lays flat for easy storage
- Lightweight
- Resists external damage, i.e., crushing

### RF-FDACCRR – Crush Resistant Features

- Crush and kink resistant
- Microbe and Bacteria free tube will not impart taste or odor
- Ozone and mild chemical resistance

### Applications

- Milk product and milk transfer
- Milk transfer
- Water transfer
- Food and beverage
- Cosmetics
- CIP pharmaceutical applications
- Chemical transfer
- Dairy

### Connections

- Stainless steel or non-metallic radially-cripped fittings

### Also Available

- Rubber Fab offers a full line of high purity gaskets from mini to 12".



Rubber Fab Technologies Group  
Limecrest Road  
P.O. Box 626 • Andover, NJ 07821  
phone: 973-579-2959 fax: 973-579-7275  
[www.rubberfab.com](http://www.rubberfab.com)

Rubber Fab Technologies Group is a member of:



Rubber Fab Technologies Group's

**TUF-FLEX<sup>®</sup>**

The Finest Gasket  
In The World



Revolutionary Construction

Exceptional Purity

Superior Performance

Animal Derived Ingredient Free



# TUF-FLEX®

## Introducing a Technologically Advanced New Hygienic Seal

Tuf-Flex, the **revolutionary new hygienic seal** from Rubber Fab Technologies Group, is the **world's only unitized seal** setting new standards for **purity, performance and flexibility**. Designed to meet critical requirements in pharmaceutical, biotechnology, ultra-pure water, WFI (water-for-injection) and difficult food and beverage processing, **Tuf-Flex outperforms other hygienic seals while eliminating costly process interruptions.**

## Performance Based on a Revolutionary Composition

A Tuf-Flex hygienic seal's contact surface is a layer of PTFE grafted to an EPDM rubber inner core. This **totally bonded construction** provides an **exceptionally pure and incredibly flexible seal.**

By grafting the elastomer with a layer of PTFE, **Tuf-Flex will behave like an elastomer but will prevent the product contamination, service interruptions and clean-up costs** associated with elastomer seals.



## Performance With Exceptional Purity

Because its elastomer core is protected by a unitized layer of PTFE, Tuf-Flex hygienic seals will not **release elastomer extractables** or **particulates** totally **eliminating spalling**. The result is an **exceptionally maintained sanitary tubing I.D. with no I.D. invasiveness or system contamination.**

## Achieve Higher Performance Under SIP/CIP Conditions

- Uniting the **flexibility** of an elastomer with the **chemical resistance** of PTFE
- **Seats perfectly**
- **Superior resistance to cold flow and creep**
- **Excellent chemical resistance**
- **Minimal thermal expansion**

- **Leak-proof performance**
- **Outstanding service life**
- **Exceptional flexibility**

## Tuf-Flex Is Ultra-Pure

- **No extractables, TOCs or particulates** to contaminate product stream
- **No-pigment**
- **No gasket I.D. invasion**
- **Exceptional cleanability response**
- **Non-stick surfaces**
- **Maintains seal @ 30 in./lbs.**
- **Temperature Range: -20°F to 400°F**

## Tuf-Flex Prevents Process Interruptions

- **Perfect cleanability**
- **No re-torquing**
- **Up to 100 SIP cycles guaranteed**

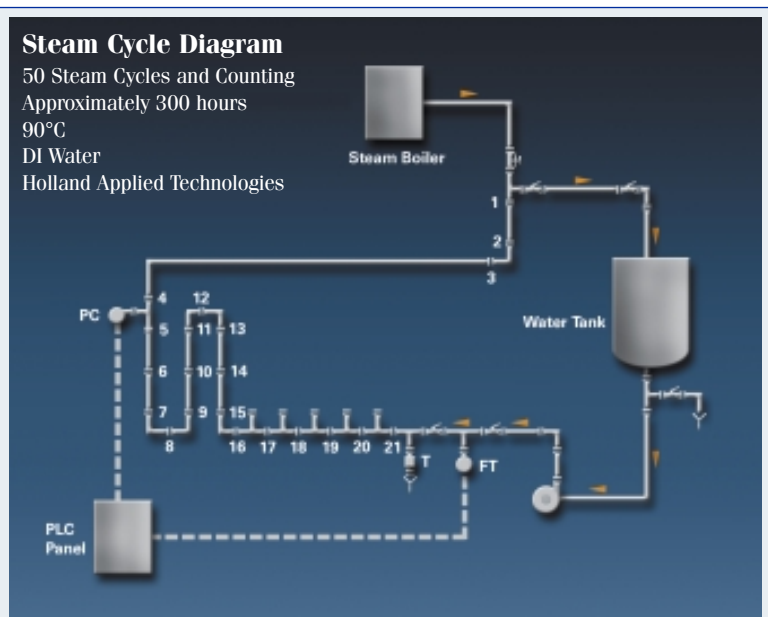

**TUF-FLEX Hygienic Seal Life Study**

Product	Material	Durometer Before	Durometer After	I.D. Dia. Before	I.D. Dia. After
TUF-FLEX	PTFE	92	94	1.406	1.39
TUF-FLEX	EPDM	92	95	1.406	1.366

## Type I and Type III Envelope Seals vs TUF-FLEX



A Solid PTFE Type I seal is guaranteed to fail in SIP conditions. They will creep, cold flow and leak at  $\Delta T$ .



The Envelope seal construction provides **inconsistent** results between the two materials. It will also creep, cold flow and leak over time.



The PTFE grafted elastomer in a Tuf-Flex seal will maintain I.D. without re-torquing or leaking.

### TUF-FLEX Hygienic Seal

Item	Unit	Spec.	"A" Type	"B" Type
<b>Normal Condition Test</b>				
Hardness	HS (JIS A)	80 $\pm$ 5	82	77
Tensile Strength	M Fa	9.8 Min.	18.5	16.7
Elongation	%	150 Min.	160	310
<b>Aging Test</b>				
Hardness Change	POINTS	+5 Max.	+1	+2
Tensile Strength Change	%	-15 Max.	-3.2	-7.2
Elongation Change	%	-25 Max.	-11.6	-19.4
<b>Compression Set Test</b>				
Compression Set	%	+25 Max.	+7	+13

### TUF-FLEX...The World's Only Unitized Hygienic Seal



1/2"	A42MPGR-TF-050-E
3/4"	A42MPGR-TF-075-E
1"	A40MPGR-TF-100-E
1-1/2"	A40MPGR-TF-150-E
2"	A40MPGR-TF-200-E
2-1/2"	A40MPGR-TF-250-E
3"	A40MPGR-TF-300-E
4"	A40MPGR-TF-400-E



## Specify Tuf-Flex®, the World's Finest Hygienic Seal

- Unites the **flexibility** of an elastomer with the **chemical resistance** of PTFE.
- Up to 100 steam cycles guaranteed.
- **Totally unitized**, perfectly sealed.
- **Leak-proof performance.**
- Superior **creep resistance.**
- Excellent **chemical resistance.**
- Minimal thermal expansion.
- No re-torquing necessary.
- Outstanding service life.
- **Outstanding purity** – no extractables, TOCs or particulates.
- No gasket extrusion into the I.D.
- **Non-stick surfaces.**
- **No pigments.**
- Easy cleanability.

## Tuf-Flex Meets Stringent Standards

- U.S. Pharmacopeia Class VI Certification
- Cytotoxicity Criteria
- Title 21 CFR 177.2600 and 177.1550
- USDA and 3-A Sanitary Standards
- Current Good Manufacturing Practices (CGMP)
- ASME-BPE Standards
- Animal Derived Ingredient Free

© Tuf-Flex and ADI Free are registered trademarks of Rubber Fab Technologies Group.

\* Buna is not an ADI Free elastomer.



Rubber Fab Technologies Group  
Limecrest Road

P.O. Box 626 • Andover, NJ 07821  
phone: 973-579-2959 fax: 973-579-7275

[www.rubberfab.com](http://www.rubberfab.com)

## New From Rubber Fab Technologies Group



**Design...Validation...Production  
...Quality Assurance**  
*Improving Product Quality  
and Consistency.*

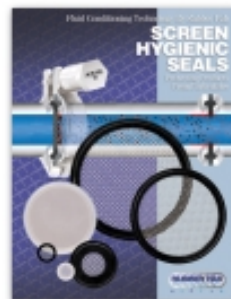
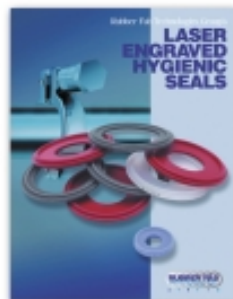

*Rubber Fab Technologies Group, a Material Science Company, is a leading innovator of high quality sanitary hygienic seals, hose assemblies, valve, pump and filler machine components in a wide range of high purity elastomer materials. For additional information, contact Rubber Fab at 973-579-2959 or visit us at [www.rubberfab.com](http://www.rubberfab.com).*

Rubber Fab Technologies Group is a member of:

Distributed by:



# Rubber Fab Technologies Group's **GAUGE GUARD ISOLATOR HYGIENIC SEALS**

Protect Critical Instrumentation  
With No Performance Loss



The Rubber Fab Gauge Guard Isolator seals **protect expensive diaphragm and instruments from damage without affecting instrument performance**. By combining a quality Rubber Fab hygienic seal with a membrane, the Gauge Guard Isolator hygienic seal **isolates hot or caustic saline solution from instrumentation**. A necessary and **cost effective** step in **assuring long life and accurate results from your instruments and gauges**. As some manufacturers will suggest the use of a gauge guard seal, others note that the **failure to use a gauge guard seal can void most instrument and gauge warranties**.



## All the Rubber Fab Benefits in a Gauge Guard Hygienic Seal

- Seal membrane **protects instrumentation from caustic saline solutions**
- **Will not interfere with gauge operation or accuracy**
- Works with most industry standard instruments
- Helps **extend the life** of gauges
- Available in:  
**FKM Fluoroelastomer**  
**Platinum Silicone**  
**EPDM**
- 1/2" and 3/4" – .015 membrane thickness
- 1", 1-1/2" and 2" – .010 membrane thickness
- Metal Detectable elastomers available

## All Rubber Fab Hygienic Seals Meet the Stringent Standards For Purity

- U.S. Pharmacopeia Class VI Certification
- Cytotoxicity Criteria
- Title 21 CFR 177.2600
- USDA and 3-A Sanitary Standards
- Current Good Manufacturing Practices (CGMP)
- ASME-BPE Standards
- Animal Derived Ingredient Free

© ADI Free is a registered trademark of Rubber Fab Technologies Group.

Rubber Fab Technologies Group's Metal Detectable products are patent pending.



Rubber Fab Technologies Group  
Limecrest Road

P.O. Box 626 • Andover, NJ 07821

phone: 973-579-2959 fax: 973-579-7275

[www.rubberfab.com](http://www.rubberfab.com)

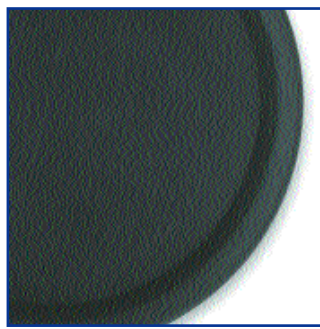

### FKM Fluoroelastomer

1/2"	42GGI-SFY-050
3/4"	42GGI-SFY-075
1"	40GGI-SFY-100
1-1/2"	40GGI-SFY-150
2"	40GGI-SFY-200



### Platinum Silicone

1/2"	42GGI-PX-050
3/4"	42GGI-PX-075
1"	40GGI-PX-100
1-1/2"	40GGI-PX-150
2"	40GGI-PX-200

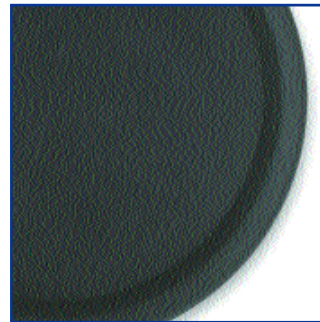

### EPDM

1/2"	42GGI-E-050
3/4"	42GGI-E-075
1"	40GGI-E-100
1-1/2"	40GGI-E-150
2"	40GGI-E-200

## New From Rubber Fab Technologies Group

**DESIGN**  
validation  
production  
**QUALITY ASSURANCE**

Improving Product Quality and Consistency

**RUBBER FAB**

**Design...Validation...Production  
...Quality Assurance**  
*Improving Product Quality and Consistency.*

Rubber Fab Technologies Group is a member of:

Distributed by:



Rubber Fab Technologies Group's

# CONTROLLED COMPRESSION GASKETS

Controlling the  
Compressive Load to  
Provide the Ultimate  
Surface I.D.



## Introducing the Controlled Compression Gasket

### A Superior Hygienic Seal

**The Controlled Compression Gasket cannot be over-tightened!**

The CCG is composed of the elastomer of your choice with a ring of ultem® vulcanized inside the seal from the ring O.D. to the locating ring. This **non-compressible** polymer controls clamp compression to **exactly** the correct amount, allowing the properly positioned seal to make a perfect surface I.D. with the ferrules. **No intrusion of the hygienic seal** in the product flow is possible.

The Controlled Compression Gasket literally transforms the tri-clamp connection into a **perfect I.D. connection**. Because the ultem ring acts as a **positive mechanical compression stop** when clamping, the clamp will not loosen due to seal creep, aging or  $\Delta T$  cycles. This is true for any **standard or high pressure clamp** regardless if the clamp is secured with a wing nut, standard nuts or Rubber Fab's Torque-Rite®

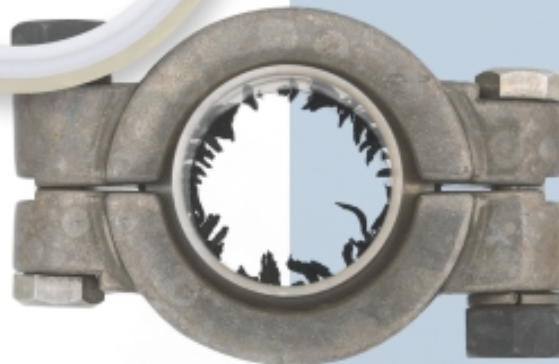

*Over-tightening causes hygienic seal intrusion into the piping I.D. which can result in tearing and sticking resulting in system contamination.*

*Rubber Fab's Controlled Compression Gaskets act as a positive mechanical stop making "over-tightening" virtually impossible.*

- Hygienic seal meets ASME-BPE intrusion requirement of  $\pm .020$ .
- Works with virtually any manufacturer's ferrules, fittings, clamps or combination thereof.
- No torque requirement. Tighten until it stops (we suggest wetting the gasket with isopropyl alcohol during installation to insure uniform compression, especially the 1" CCG).
- The CCG hygienic seal will allow for slight misalignment and ferrule face anomalies.
- Available in EPDM, FKM and silicone.
- Can be tabbed for traceability or non-tabbed with laser engraved batch and lot information.
- FDA compliant, 3A and Class VI tested.
- First major gasket design patent issued in the last 60 years.



## Controlled Compression Gaskets

- Hygienic seal material will not extrude into I.D. maintaining perfect surface I.D.
- Transforms tri-clamp fittings into a perfect I.D. connection.
- Maintains seal after thermal cycling.
- No re-tightening required.
- Complete control over amount of compression load on seal material.
- Creates a static and leak tight seal.
- Makes over-torquing impossible.
- Superior cleaning, draining and sanitization guaranteed.
- Certain elastomers can withstand up to 100 steam cycles.
- Prevents soil retention and fluid hold-up.
- Tabs indicate lot, batch, manufacture date, size and materials used.
- Constant lot and batch traceability.
- Tabs insure no potential human contamination during installation.
- Works with standard and high pressure clamps.
- 1" to 3" sizes available (excluding 2-1/2").
- Complete traceability with color coded system.
- Adjusts for misalignment.
- Available standard or tabbed.
- Metal Detectable Elastomers available.

© Torque-Rite and ADI Free are registered trademarks of Rubber Fab Technologies Group.

Controlled Compression Gasket: United States Patent Number 6,857,638.

Torque-Rite: United States Patent Number 6,082,941.

Rubber Fab Technologies Group's Metal Detectable products are patent pending.

© Ultem is a registered trademark of GE.

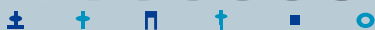
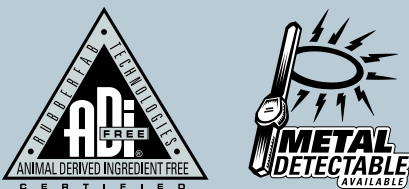

Rubber Fab Technologies Group  
Limecrest Road

P.O. Box 626 • Andover, NJ 07821

phone: 973-579-2959 fax: 973-579-7275

[www.rubberfab.com](http://www.rubberfab.com)

## Perfect...Every Time

Because there is **no unsupported hygienic seal intruding into the product flow**, the seal's **service life is greatly extended**. With the minimum surface contact area exposed, particulates, TOCs and other extractables are dramatically reduced.

- Compression of the hygienic seal surface is more than adequate to compensate for imperfections in ferrule faces. The ultem® ring is ductile enough to allow for piping misalignment.
- The lettering on the ultem ring indicates the elastomer type. Ring can be a sanitary Type I standard style or tabbed. Tabbed ring provides permanent record of batch and lot number as well as date of manufacture for tracking. The tabbed ring allows customer to eliminate human contact with the hygienic seal surface and an area to record date of installation on the reverse side of the tab.
- Ultem is an FDA compliant, USP Class VI approved, non

compressible polymer. Maximum operating temperature rating is 450°F. Controlled Compression Gaskets can be autoclaved and depending on the elastomer selection can withstand up to 100 steam cycles.

## Meeting the Stringent Standards For Purity

- U.S. Pharmacopeia Class VI Certification
- Cytotoxicity Criteria
- Title 21 CFR 177.2600
- USDA and 3-A Sanitary Standards
- Current Good Manufacturing Practices (CGMP)
- ASME-BPE Standards
- Animal Derived Ingredient Free

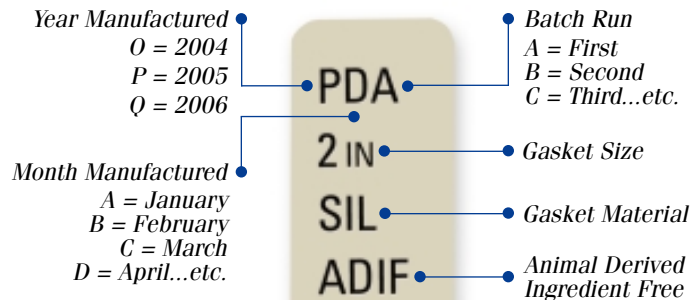

## Creating a Sanitary Tracking and Coding System

Rubber Fab Technologies Group is a member of:

Distributed by:



S U P E R I O R T E C H N O L O G Y

Rubber Fab Technologies Group

# REPLACEMENT FILLER PARTS

*Parts to fit  
Cherry Burrell®,  
Evergreen® and  
International Paper®  
Equipment.*



**W**e have approached filler parts with the same perspective as all

Rubber Fab programs: Provide equal or better products and design in geometric and material features that meet the evolving demands in a progressive industry. We have provided products to service higher temperatures, unique screen meshes and perforated plate openings and other design criterion changes. We can design filler replacement products so that they are specifically tailored to your applications.

Take advantage of Rubber Fab's extensive inventory of replacement filler parts to service your end users so that they can save time and money, improve their operational uptime and realize better overall service. Make filler parts a big part of your sales and service product line. Inquire for price and availability on our in-stock inventory of Rolling Diaphragms, Screen and Perforated Plate Gaskets, U-Cups, Vacuum Cups, O-Rings, Burst Disc Gaskets, Defoamers, Carbons, and many other replacement products. We can use our large variety of materials to make custom parts in Tuf-Steel®, Buna, PTFE, EPDM, FKM and Silicone. We also offer other unique polymer blends, including a full line of metal detectable elastomer products, to meet your challenging requirements.



## Rolling Diaphragms

Rubber Fab's stock of Rolling Diaphragms are comprised of 3A, FDA compliant cloth reinforced EPDM elastomers. Designed to have the most flex life in filling applications, they meet the high temperature demands required when aseptic processing. Our Rolling Diaphragms are steam resistant and rated for 350°F. Try them for yourself and you will see equal or improved stroke and fatigue life. Diaphragms in stock include part numbers 5541991 and 5541888.

### Rolling Diaphragm

3285100	Rolling Diaphragm
5541888	Rolling Diaphragm
5541991	Rolling Diaphragm

## Screen and Orifice Plates

Rubber Fab supplies Screen Gaskets with rubber bonded to a 316 stainless steel screen, and Perforated Plate Gaskets with rubber bonded to a 316L stainless steel plate. We stock the standard sizes and dimensions as the OEM supplies including 5905141, 5904179, 5904180, and 5905060.

Custom screen and gasket products include optional polymer choices to more specifically meet your applications. Screens or Plates can be ordered with any elastomer, PTFE, or Tuf-Steel®. Provide the details of your application or cause of failure and we will determine the material that will perform best. Materials like Tuf-Steel® have never before been offered in sanitary filler equipment. Tuf-Steel® has the ultimate temperature and steam resistance for use in aseptic processing applications.

Rubber Fab can also mold custom perforated plate and screen sizes into the gasket dimensions that are designed to fit your Evergreen® fittings. Specify the design or let our experts develop your ideal screen or perforated plate gasket.

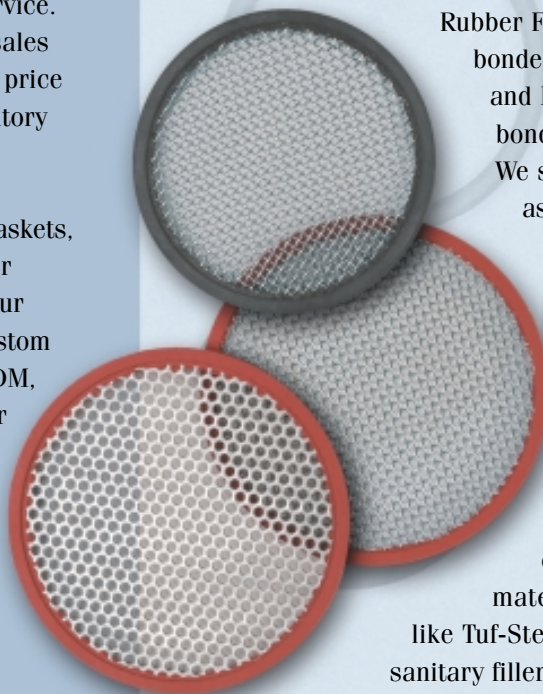



## Gaskets

Rubber Fab manufactures Q-Line, I-Line, Burst Disc, and Clamp style gaskets as required for Evergreen® fillers molded in FDA compliant and 3A approved compounds. Standard and optional compounds include EPDM in white or black, FKM, Silicone, PTFE, and Tuf-Steel™ for challenging aseptic applications. Part numbers 5540324, 5540325, 5540326, 5540327, 5540328, 5540329, 5540330, 5540331, 5540332, 5540333, 5541950 through 5541960, and many others. Order by Evergreen part numbers or call out the industry standard part number for your application.

Screen and Perforated Plate Gaskets	
RF3158320	Screen Nozzle Perforated Plate
RF3282724	Screen Nozzle Perforated Plate
RF5903966	Screen Nozzle Gasket Assembly
RF5904054	Screen Nozzle Gasket Assembly
RF5904179	Screen Nozzle Gasket Assembly
RF5904180	Perforated Plate Gasket Assembly
RF5904703	Screen Nozzle Gasket
RF5905060	Screen Nozzle Gasket
RF5905141	Screen Nozzle Gasket-FKM
RF5905141s	Screen Nozzle Gasket Silicone
RF5904469	Screen Nozzle Gasket Assembly
RF7150440	Perforated Plate Defoamer
RF7150441	Screen Defoamer

## Gaskets

RF5540324	40IH-1" I-Line-Buna (Black)
RF5540325	40IH-1.5" I-Line-Buna (Black)
RF5540326	40IE-200 I-Line-Buna
RF5540327	40IH-250 I-Line-Buna
RF5540328	40IH-300 I-Line-Buna
RF5540329	40IH-400 I-Line-Buna
RF5540332	Large Flat Gasket
RF5540398	1" x 1.5" 40 IH Gasket
RF5540399	40QH-100, 1" Q-Line-Buna
RF5540400	40QH-150, 1.5" Q-Line-Buna
RF5541570	1.5" 40MPSFY FKM Gasket
RF5541571	2" 40MSPFY FKM Gasket
RF5541725	40IE-W-150 I-Line-EPDM
RF5541726	40IE-W-200 I-Line-EPDM
RF5541727	40IE-W-250 I-Line-EPDM
RF5541728	40IE-W-300 I-Line-EPDM
RF5541924	40IE-100 I-Line-EPDM
RF5541954	Gasket Silicone
RF5541959	Gasket Silicone
RF5541960	Gasket Silicone

## O-Rings

Rubber Fab has a large inventory of O-Rings for Cherry Burrell®, Evergreen, International Paper®, Pure Pak®, Liqui-Box®, Nimco®, Gram®, Sweetheart®, Portion Pak®, Anderson® and other sanitary fillers. Standard materials available include Buna, EPDM, FKM and Silicone. As with other Rubber Fab products, we can solve your needs with custom compounds and optional materials.



## U-Cups

Rubber Fab offers U-Cups that match the material and dimensional specifications of OEM fillers. Red Silicone, Buna and EPDM materials are immediately available.

## Vacuum and Suction Cups

Rubber Fab pays close attention to the design material choice of our Vacuum and Suction Cups to ensure proper function in your application. You will use our Vacuum and Suction Cups with confidence when you buy from Rubber Fab.

### O-Rings

RF5540006	O-Ring
RF5540044	O-Ring
RF5540072	O-Ring
RF5540121	O-Ring
RF5540127	O-Ring
RF5540130	O-Ring
RF5540147	O-Ring
RF5540165	O-Ring
RF5540186	O-Ring
RF5540192	O-Ring
RF5540223	O-Ring
RF5540353	O-Ring
RF5540584	O-Ring-FKM
RF5540650	O-Ring-Silicone
RF5540701	O-Ring
RF5540751	Fill Nozz. Chk Vlv Body O-Ring
RF5540827	O-Ring
RF5541123	O-Ring
RF5541159	O-Ring-FKM
RF5541216	O-Ring
RF5541430	O-Ring-FKM
RF5541796	O-Ring-EPDM
RF5541798	O-Ring
RF5541847	O-Ring
RF5541848	O-Ring
RF5541922	O-Ring-FKM
RF5541951	O-Ring-FKM
RF5542065	O-Ring

### U-Cups

RF5540321	U-Cup Packing
RF5540927	U-Cup-Buna
RF5540978	U-Cup-Buna
RF5540979	U-Cup-Buna
RF5541122	U-Cup
RF5541553	U-Cup-Silicone
RF5541563	U-Cup Packing
RF5541877	U-Cup
RF5541988	U-Cup

### Suction/Vacuum-Cups

RF5900807	Vacuum Cup-EPDM
RF5900929	Suction Cup-GUM (White)
RF5902161	Vacuum Cup-EPDM
RF5903032	Vacuum Cup-FKM
RF5905051	Blue Suction Cup-Vinyl

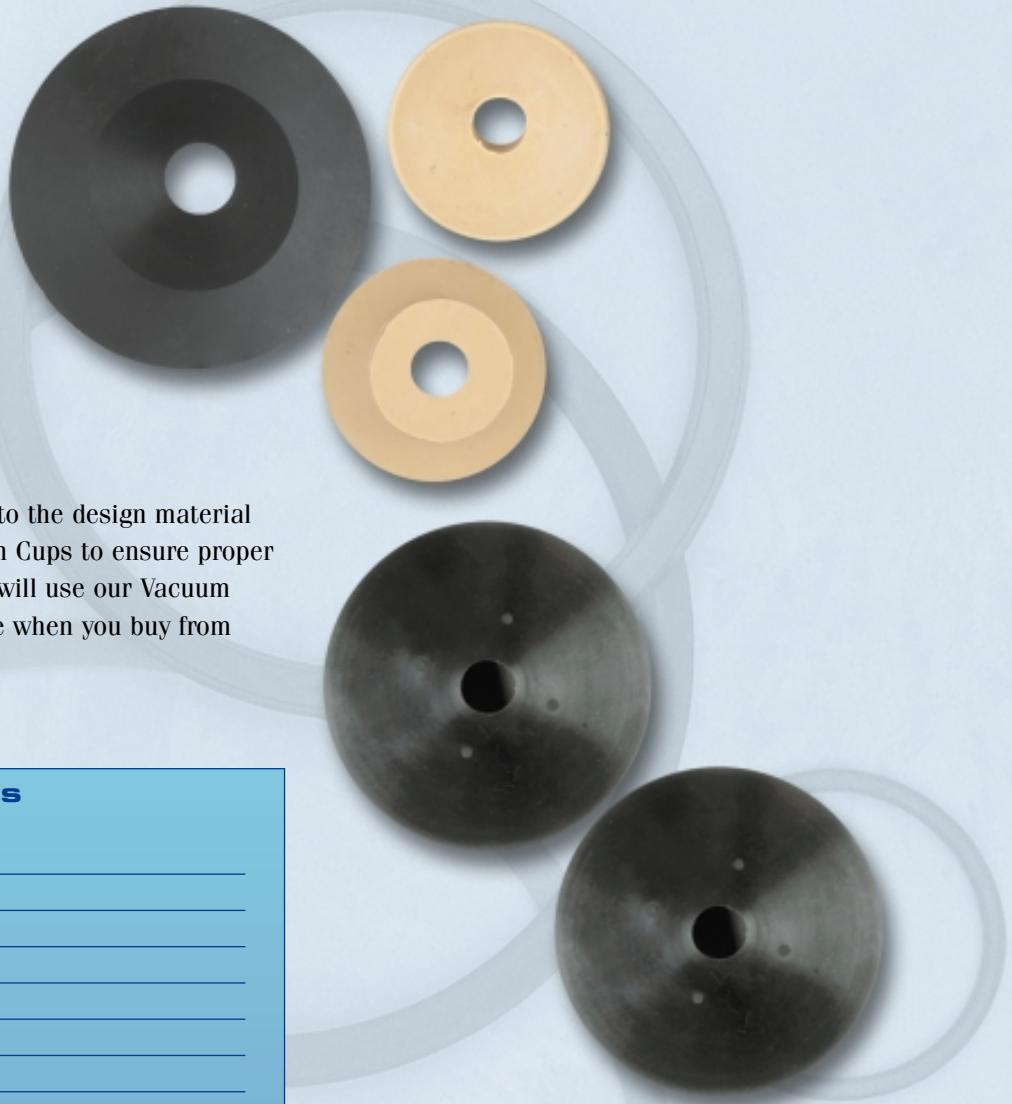

## Rubber Fab's Commitment to Quality Parts

Rubber Fab continues their tradition of manufacturing the finest quality of replacement parts for Dairy, Beverage and Juice equipment with a complete program of packaging products.

We feature rubber, PTFE, stainless steel, and rubber to metal bonded parts that fit International Paper's Evergreen® Fillers, Pure Pak® Fillers, Cherry Burrell® Fillers, and many other popular filler machines used in sanitary processing. Over the years we have established a large inventory and a successful track record of supplying filler parts that are equal to or better than previously available products. Our knowledge of polymers and high purity processing applications combine to make Rubber Fab the industry expert in supplying seal and component parts.

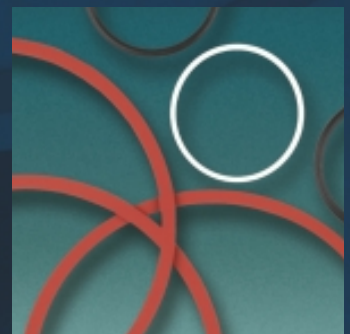
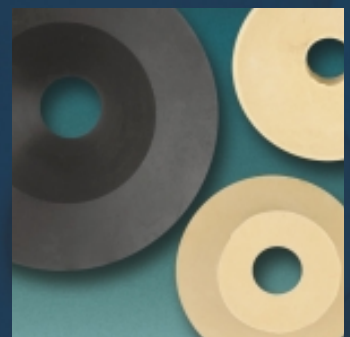
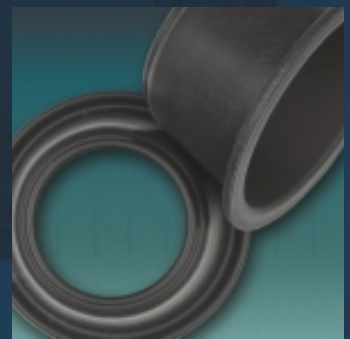

## Replacement Filler Parts from Rubber Fab

- **Parts to fit:** Cherry Burrell® Evergreen® and International Paper® Equipment and many other popular filler machines.
- **Parts include:** Rolling Diaphragms, Screen and Orifice Plates, Gaskets, O-Rings, U-Cups, Suction Cups and Vacuum Cups, and many more.
- Manufactured with **Animal Derived Ingredient Free** elastomers.\*
- **Metal Detectable elastomers** available. By manufacturing any standard elastomer with a 3A, FDA approved metal filler, a worn off piece of elastomer material can now be located by an in-line metal detector. This alarm enables your system to instantly be shut down for the removal of contaminated product and the immediate replacement of the worn part. Detectables eliminate product recall, lowers product loss and decreases the risk of elastomers consumed in finished product.

© Tuf-Steel and ADI Free are registered trademarks of Rubber Fab Technologies Group.

Rubber Fab Technologies Group's Metal Detectable products are patent pending.

\* Buna is not an ADI Free elastomer.

## Carbons, Parkut Rings, Burst Disc Gaskets, Defoamer Tubes, Displacers, Springs, Quad Rings, and Flexible Couplings are some of the many additional Filler Parts offered by Rubber Fab

Rubber Fab is not limited in filler parts to what we list here. We are adding products everyday. Provide your OEM part number to Rubber Fab and we will quote you on any item not listed.

### Additional Filler Parts

RF2143800	HL90 Level Gauge Diaphragm
RF3151819	Burst Disc Gasket
RF3152844	Dust Cover
RF3157237	Retainer-O
RF5540808	HI90 Product Bowl Gasket
RF5541594	Rod Wiper
RF5541599	QPC-11 Product Bowl Gasket
RF5541794	Seal Parkut Ring
RF5541939	Metering Bowl Gasket
RF5902593	Spring
RF5902770	Carbon
RF5902771	Collar
RF5904154	Flex Coupling 1.5" (White)
DTNEP-33.5	Defoamer Tube
DTH90-36	Defoamer Tube



Rubber Fab Technologies Group  
Limecrest Road

P.O. Box 626 • Andover, NJ 07821  
phone: 973-579-2959 fax: 973-579-7275

[www.rubberfab.com](http://www.rubberfab.com)

Rubber Fab Technologies Group is a member of:



International Association of  
Food Industry Suppliers



Distributed by: