

FLEXIBLE SILICONES TUBES

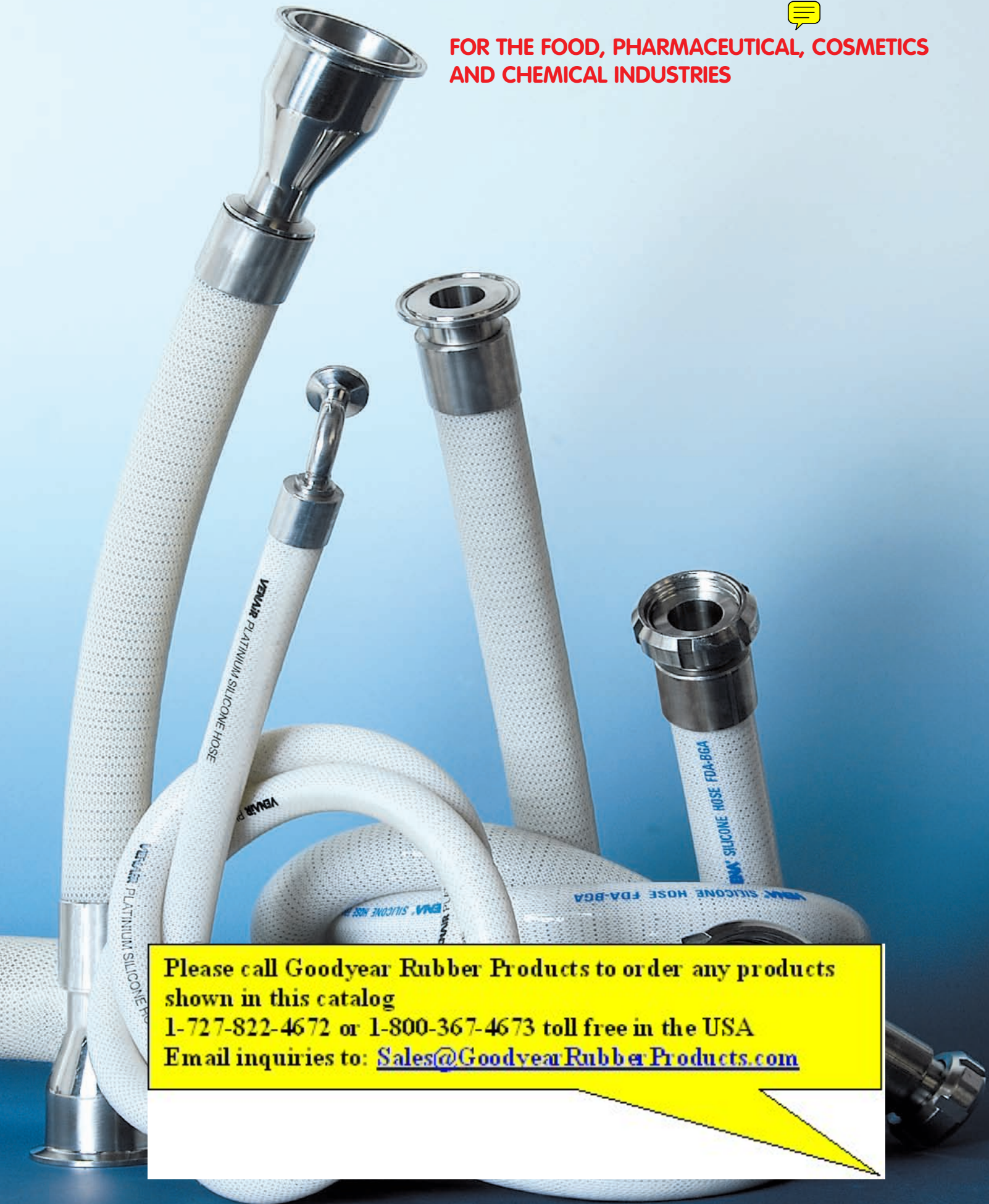

FOR THE FOOD, PHARMACEUTICAL, COSMETICS
AND CHEMICAL INDUSTRIES



Please call Goodyear Rubber Products to order any products
shown in this catalog

1-727-822-4672 or 1-800-367-4673 toll free in the USA

Email inquiries to: Sales@GoodyearRubberProducts.com

FLEXIBLE SILICONE TUBES

FOR THE FOOD, PHARMACEUTICAL, COSMETICS, AND CHEMICAL INDUSTRIES

Product Use and Characteristics:

These tubes are used for transporting liquid or semi-liquid products by suction or impulsion. They are manufactured from silicone elastomers prepared in compliance with the FDA (Food & Drug Administration) 21 CFR 177.2600 and USP Class VI standards in the United States and the FDA-BfR Part XV standard in Germany. Documentation of these certifications can be provided upon request.

All tubes are manufactured with platinum-cured silicone, the highest quality in today's market and in accordance with the ISO 9002 standard.

Silicone Properties:

This elastomer is **inalterable, odorless, non-sticky, and water repellent**. It can be sterilized with argon, cobalt, or steam (within a maximum recommended time of 1h 30 min. at 140°C/ 284°F), and is completely non-toxic. The composition includes components such as silicone, talc, and quartz, as well as additional loads authorized by the FDA.

The raw material has been prepared by our suppliers for operation without alterations at temperatures ranging from -80°C to +240°C (-112°F to +464°F). Original lot numbers of raw materials are readily verifiable.

Platinum-cured:

VENAIR Technosil's peroxide-free platinum-cured silicone tubes are highly recommended for pharmaceutical and food processing applications. These tubes ensure more hygienic conditions since, upon curing, the chromatographic phase is of higher purity than that found in tubes with peroxide catalysis-- a prime characteristic important in the pharmaceutical sector.

SZR' system:

Thus, VENAIR Technosil flexible silicone tubes are highly recommended where stringent aseptic conditions are required. The tubes can be joined by 316L stainless steel fittings equipped with the SZR system. The SZR system eliminates an area of possible contamination, thus facilitating Cleaning in Place (CIP). As a result, tubes equipped with these 316L stainless steel fittings do not need to be disassembled for cleaning.

Sectors of Use:

Due to its versatility, and its ability to be used in suction or impulsion (pressure or vacuum), VENAIR Technosil flexible silicone tubes are advantageous in the following sectors as well:

- Food Processing
- Cosmetics Processing
- Pharmaceutical Processing

NOT AUTHORIZED FOR USE IN MEDICINAL APPLICATIONS.

These flexible silicone tubes can also withstand extreme temperatures, conserving their mechanical properties at temperatures ranging from -60°C (-76°F) to +200°C (+392°F). Upon request, silicone tubes with more extreme resistance can be manufactured. These include our PVMQ silicone for very low temperatures (-100°C/ -148°F) and THT silicone for very high temperatures (+300°C/ +572°F)

Certifications:

FDA – BGA CERTIFICATES OF CONFORMITY

FDA 21 CFR 177.2600* and FDA-BfR Part XV standard in Germany

Other characteristics:

Standard Manufacturing Length: 4 meters
Upon request, shorter lengths can be manufactured.

Standard Tube Color: Translucent
Exterior tube color can be customized to help distinguish products passed through tubes without sacrificing inner tube properties.

Inner Reinforcement: Polyester
Other options: MIF Polyester, Nomex .
Standard hardness: 60 shores (possible range of 50 – 70 shores).

(1) **SZR** is a registered trademark of **VENAIR**.

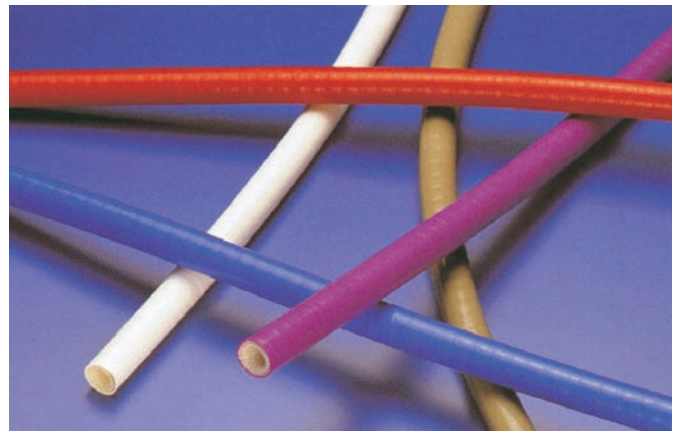

(2) **NOMEX** is a registered trademark of DUPONT.

VENASIL 640

MANUFACTURE:

The **VENASIL 640** type silicone tube complies with FDA 21 CFR 177.2600, USP Class VI, and FDA-BfR Part XV standard in Germany. It is a platinum-cured, high purity tube, manufactured with four polyester fabric reinforcements. A more reinforced version (640 MIF) can also be manufactured that allows the tube to withstand higher pressure.

Inner appearance: Translucent and smooth.

Outer appearance: Translucent, white or colored, and smooth.

Applications: For use in straight sections equipped with metal fittings terminals, where flexibility is not required. This model is used often to detect metal particles which may occur during filling of food products such as cream or baby food. This type of tube is not recommended for operation with negative pressure (vacuum).

Silicone material option:

- FDA/ BfR Part XV
- FDA/ BfR Part XV Platinum Cured
- USP Class VI Platinum Cured



Inner Diameter*		Wall Thickness +1-0.5 (mm)	Working Pressure**				Bursting Pressure**			
			bar @ 20°C ISO 1402/1994		psi @ 68°F ISO 1402/1994		bar @ 20°C ISO 1402/1994		psi @ 68°F ISO 1402/1994	
(mm)	(inch)		640	640 MIF	640	640 MIF	640	640 MIF	640	640 MIF
6	1/4	4.5	11,5	23,6	169	342	35,0	71	508	1030
8	5/16	4.5	10,7	20,5	155	297	32,0	61	464	885
10	3/8	4.5	9,7	18,3	140	265	29,0	55	421	798
13	1/2	4.5	8,7	16,0	126	232	26,0	48	377	696
16	5/8	4.5	8,0	14,5	116	210	24,0	43	348	624
19	3/4	4.5	7,7	12,9	111	187	23,0	39	334	566
22	7/8	4.5	7,0	12,3	102	178	21,0	37	305	537
25	1	4.5	6,7	11,6	97	168	20,0	35	290	508
32	1 1/4	4.5	5,7	10,2	82	148	17,0	31	247	450
38	1 1/2	4.5	5,0	9,4	73	136	15,0	28	218	406
51	2	4.5	4,0	8,1	58	117	12,0	24	174	348
63	2 1/2	4.5	3,3	6,9	48	100	10,0	21	145	305
76	3	4.5	2,7	5,7	39	83	8,0	17	116	247
102	4	4.5	1,7	3,3	24	48	5,0	10	73	145

The standard manufacturing length is 4 m (13'). Upon request, 6 m length tubes (19' 8") can be manufactured.

* Other diameters can also be manufactured. Please consult.

** Pressure data is noted at ambient temperature. Please reduce pressure values by 20% for each increase of 212°F.

VENASIL 650V

MANUFACTURE:

The **VENASIL 650V** type silicone tube complies with FDA 21 CFR 177.2600, USP Class VI, and FDA-BfR Part XV standard in Germany. It is a platinum-cured high purity tube, manufactured with four polyester fabric reinforcements and 302L stainless steel wire spring encased inside the tube.

Inner appearance: Translucent and smooth.

Outer appearance: Translucent (standard) or colored (special order), and smooth.

Silicone material option:

- FDA/ BfR Part XV
- FDA/ BfR Part XV Platinum Cured
- USP Class VI Platinum Cured



Inner Diameter*		Wall Thickness +1-0.5 (mm)	Theoretical Outer Diameter		Bending Radius (mm) ISO 1746/1983	Working Pressure**		Bursting Pressure**		Vacuum tolerance
(mm)	(inch)		(mm)	(inch)		bar @ 20°C ISO 1402/1994	psi @ 68°F ISO 1402/1994	bar @ 20°C ISO 1402/1994	psi @ 68°F ISO 1402/1994	
6	1/4	5,5	17,0	0,67	29	13,0	188	38,9	565	684 Torr (mmHg) 0,91 bar 0,90 atm 9,29 mH2O 13,23 psi 26,93 inHg
8	5/16	5,5	19,0	0,75	31	12,0	174	36,0	522	
10	3/8	5,5	21,0	0,83	34	11,0	159	32,9	478	
13	1/2	5,5	24,0	0,94	39	9,9	144	29,8	433	
16	5/8	5,5	27,0	1,06	45	9,1	132	27,4	397	
19	3/4	5,5	30,0	1,18	54	8,3	120	24,8	359	
22	7/8	5,5	33,0	1,30	60	7,9	114	23,7	343	
25	1	5,5	36,0	1,42	68	7,4	107	22,2	321	
32	1 1/4	5,5	43,0	1,69	94	6,4	93	19,3	279	
38	1 1/2	5,5	49,0	1,93	112	5,7	83	17,2	250	
51	2	5,5	62,0	2,44	144	4,6	67	13,8	200	
63	2 1/2	5,5	74,0	2,91	181	3,8	55	11,3	164	
76	3	6	88,0	3,46	232	3,0	44	9,1	132	
102	4	6	114,0	4,49	367	1,9	27	5,6	82	

The standard manufacturing length is 4 m (13'). Upon request, 6 m length tubes (19' 8") can be manufactured.

* Other diameters can also be manufactured. Please consult.

** Pressure data is noted at ambient temperature. Pressure values should be reduced by 20% for each increase of 212°F.

VENA SIL 655

MANUFACTURE:

The **VenaSIL 655** silicone tube complies with FDA 21 CFR 177.2600, USP Class VI, and FDA-BfR Part XV standard in Germany. It is a platinum-cured high purity tube, manufactured with four polyester fabric reinforcements and 302 L stainless steel wire spring encased inside the tube at different levels.

For higher pressure applications, we also offer a reinforced version (**655 MIF**).

Inner appearance: Translucent and smooth.

Outer appearance: Translucent (standard) or colored (special order), and smooth.

Applications: A sturdier, extremely flexible product line, even in large diameters. Designed for use at specific points where there may be sudden high pressure surges (hammering). It is the strongest tube in the VenaSil range.

Silicone material option:

- FDA/ BfR Part XV
- FDA/ BfR Part XV Platinum Cured
- USP Class VI Platinum Cured



Inner Diameter*		Wall Thickness	Theoretical Outer Diameter		Bending Radius (mm) ISO 1746/1983	Working Pressure**		Bursting Pressure**		Vacuum tolerance
(mm)	(inch)		(mm)	(inch)		bar @ 20°C ISO 1402/1994	psi @ 68°F ISO 1402/1994	bar @ 20°C ISO 1402/1994	psi @ 68°F ISO 1402/1994	
6	1/4	6,5	19,0	0,75	43	21,0	305	63,0	914	684 Torr (mmHg) 0,91 bar 0,90 atm 9,29 mH2O 13,23 psi 26,93 inHg
8	5/16	6,5	21,0	0,83	46	19,3	280	58,0	841	
10	3/8	6,5	23,0	0,91	49	18,0	261	54,0	783	
13	1/2	6,5	26,0	1,02	54	16,3	237	49,0	711	
16	5/8	6,5	29,0	1,14	59	15,0	218	45,0	653	
19	3/4	6,5	32,0	1,26	68	13,7	198	41,0	595	
22	7/8	6,5	35,0	1,38	72	13,3	193	40,0	580	
25	1	6,5	38,0	1,50	80	12,3	179	37,0	537	
32	1 1/4	6,5	45,0	1,77	100	11,0	160	33,0	479	
38	1 1/2	7	52,0	2,05	121	10,0	145	30,0	435	
51	2	7	65,0	2,56	185	8,0	116	24,0	348	
63	2 1/2	7	77,0	3,03	273	6,7	97	20,0	290	
76	3	7	90,0	3,54	318	5,7	82	17,0	247	
102	4	7	116,0	4,57	423	4,0	58	12,0	174	

The standard manufacturing length is 4 m (13'). Upon request, 6 m length tubes (19' 8") can be manufactured.

* Other diameters can also be manufactured. Please consult.

** Pressure data is noted at ambient temperature. Pressure values should be reduced by 20% for each increase of 212°F.

TECHNOSIL

MANUFACTURE:

The extruded **TECHNOSIL** silicone tube complies with FDA 21 CFR 177.2600, USP Class VI, and FDA-BfR Part XV standard in Germany. The interior polyester fiber braiding allows for high pressure resistance. The braiding can be made of fiberglass for use at higher temperatures. It is not recommended for applications with negative pressure (vacuum). For vacuum applications, we recommend TECHNOSIL H-PTV.

Appearance: Translucent

Length: The standard manufacturing length is 10 meters (33'). 20 meter (66') lengths are also available.

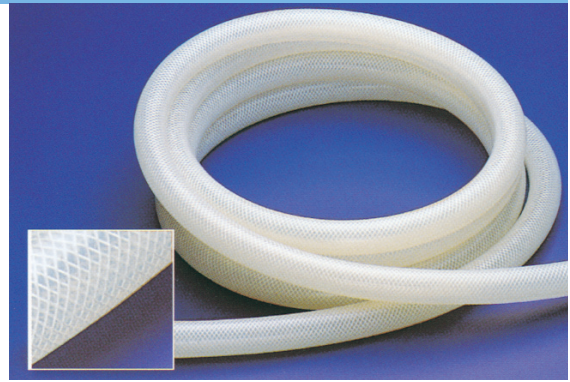

Inner Diameter*		Outer Diameter		Volumetric expansion with operating pressure	Working Pressure**		Bursting Pressure**		Bending radius (inch)
(mm)	(inch)	(mm)	(inch)		bar @ 20°C ISO 1402/1994	psi @ 68°F ISO 1402/1994	*bar @ 20°C	psi @ 68°F	
1.59	0.063	7.16	0.28		13.8	200	53.4	775	-
3.18	0.125	9.53	0.37		12.1	175	48.3	700	-
4.76	0.188	11.73	0.46		11.7	170	44.8	650	-
6.35	1/4	13.2	0.52	7.68%	9	130	28	406	1 1/2
7.93	5/16	15	0.59		7.5	108	23	333	1 3/4
9.52	3/8	16.6	0.65		7	101	21	304	2 1/4
12.7	1/2	20.3	0.80	7.42%	5	72	17	246	2 3/4
15.87	5/8	24.5	1.00		4	58	13	188	3 1/4
19.05	3/4	27.9	1.10	9.96%	3.5	50	11	159	3 3/4
22.22	7/8	31.3	1.23		3	43	10	145	4 1/4
25.4	1	34.5	1.36		3	43	9	130	5 1/4
31.75	1 1/4	40.8	1.60	14.43%	2	29	7	101	6 1/4

* The operating and bursting pressures have been tested at 20°C/68°F ambient temperature. Please decrease pressure by 20% for each temperature increase of 100°C/ 212°F.

Operating temperature: -131° F / 392° F
Hardness: 60 shores +/- 5

TECHNOSIL PLATINUM H-PTV

Inner Diameter*		Outer Diameter		Working Pressure**		Bursting Pressure**		Bending radius (inches) ISO 1746/1983
(mm)	(inch)	(mm)	(inch)	*bar @ 20°C ISO 1402/1994	(psi @ 68°F) ISO 1402/1994	*bar @ 20°C ISO 1402/1994	(psi @ 68°F) ISO 1402/1994	
5,00	3/16	11	0,43	18,0	261,1	53,0	769	1 1/2
6,35	1/4	12	0,47	17,0	246,6	50,0	725	1 3/4
7,93	5/16	15	0,59	15,0	217,6	45,0	653	2 1/4
9,52	3/8	17	0,67	14,0	203,1	42,0	609	2 3/4
12,70	1/2	22	0,87	11,0	159,5	34,0	493	3 1/4
15,87	5/8	25	0,98	10,0	145,0	30,0	435	3 3/4
19,05	3/4	31	1,22	7,0	101,5	22,0	319	5 1/4
25,40	1	38	1,50	6,0	87,0	18,0	261	6 1/4
31,75	1 1/4	46	1,81	5,0	72,5	15,0	218	8



Silicone + Fiberglass Reinforcement. Greater bending radius due to increased wall thickness. Standard production color: Orange.

SPECIAL SHAPES

VENAIR Technosil manufactures a wide range of tubes and special shapes in accordance with the most demanding market standards, satisfying all needs that may arise in processing in the food, pharmaceutical, cosmetics, or chemical industries. In an effort to be kept abreast of current trends and needs, our Research and Development department is constantly collaborating with our clients in developing new products. We encourage this interaction and value the input and insight of our clients in developing a better product for this constantly evolving market.

Examples of special products include **preformed tubes, expansion compensators, bend pipes (45° & 90° elbows) large diameters, thin wall couplings, etc.**

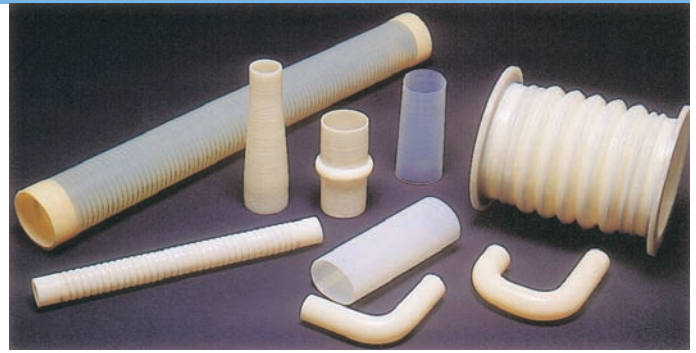

CONDUCTOR TUBES (WITH GROUND CONNECTION)

The wall interior is equipped with several tin-plated copper wires that are joined to the metal fittings by a welding point. The completely equipotent joint ensures that users will be protected from discharges of static electricity resulting from contact with the tube.



ANTISTATIC (FLAMEPROOF) TUBES

Characteristics

- **Industrial grade** (not food or pharmaceutical) silicone elastomer.
- Loaded with carbon black.
- Reinforced with several tin-plated copper wires between layers.
- Wires are joined to the metal fittings by a welding point, thus increasing the antistatic properties.
- Flameproof: Used at critical points where there may be danger of explosion when materials such as alcohol, perfume, or cosmetic products are transported at high speeds and generate static electricity.

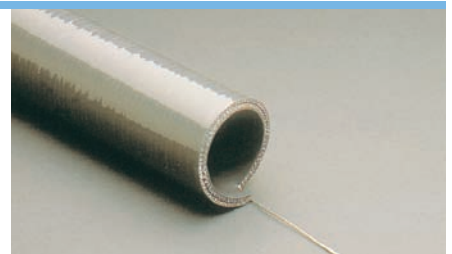

HEATED TUBES (WITH HEATING SHEATH)

VENAIR Technosil tubes can also be manufactured with a heating sheath that maintains the temperature required to transport certain products. This sheath is made of silicone-coated fiberglass fabric. A self-regulating cable runs through the inside as well. Moreover, an electronic regulation device is connected to the end of the tube to ensure the required temperature is maintained and no additional power is added when it reaches the optimum level, preventing product damage.

Voltage: 200- 240V (standard).

Other voltage possibilities exist and can be catered to user's wiring system.

Temperature:

Temperature can be regulated between +5°C to 140°C (+41°F to 284°F). The heating sheaths are manufactured according tube diameter and length. They are equipped with a fabric band that attaches both ends and can be easily disassembled.

Major Applications:

Transport of caramel, glycerine, chocolate, or other products that require a constant temperature during processing.

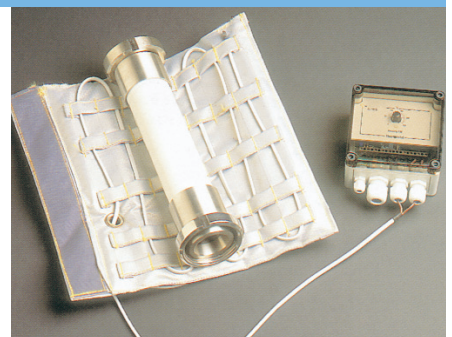

SPECIAL APPLICATIONS AND OPTIONS

All tubes in our standard product line (Sil 640, 650V, 655) can be equipped with **tin-plated copper wires** encased inside the tube to ensure protection from the static electricity that may be generated during the production processes.

HEATED TUBES (INTEGRATED SYSTEM)

Characteristics

- Equipped with a cable encased inside the wall, providing a constant power supply.
- Ensures a regular temperature to help maintain the fluidity of the product.
- Inner cable is connected to an electronic regulator and equipped with a PT 100 Ohm gauge connected to the regulator.

Voltage: Varies depending on specific user needs.

Temperature: + 5°C / + 200°C (+41°F to 392°F).

Major Applications:

With a smooth outer appearance that facilitates easier cleaning, this system is especially suitable for food, pharmaceutical, and cosmetics industries.

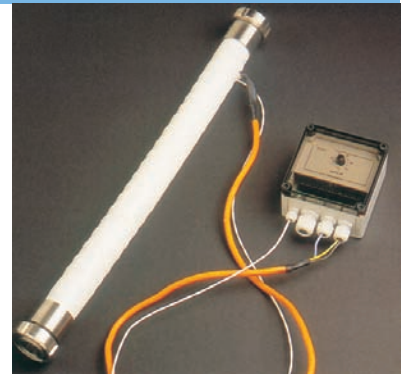

COOLING TUBES

Characteristics:

- Equipped with a cylindrical Teflon* conduit with a spiral shape, encased in the wall and running along the length of the tube.
- Fitting is assembled on both ends.
- Ensures that a regular temperature is maintained for products conveyed by steam through the inside of the Teflon conduit and for cooling with nitrogen.

Major Applications:

For all products that require high or low handling temperatures.

*Teflon is a registered trademark of DUPONT



VENA VITOSIL

Characteristics:

When the product conveyed is not compatible with the silicone elastomer, tubes with an outer appearance in compliance with 640, 650V and 655 standards, and an inner liner of white, Class A, food grade Viton can be manufactured.

Major Applications:

For use in the chemical industry, to convey particularly aggressive fluids with temperatures ranging from -30°C to +180° C (-22°F to 356°F).



VENA FLUOSIL

Characteristics:

- Inner lining made of fluorosilicone.
- Able to withstand exposure to oils and hydrocarbons.
- Manufactured in accordance with the same production standards of the standard tubes.
- **NOT food grade.**

Major Applications:

Chemical and automotive industries.

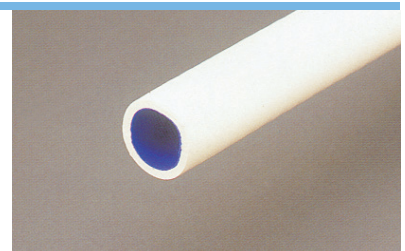

VENA PTFSIL

Characteristics:

- Manufactured with an inner liner made of PTFE tubing.
- Smooth inner surface covered with a 302L stainless steel wire helix braiding encased between the inner and outer silicone layers.
- Metal fittings assembled on both ends.
- At times, the traditional elastomers are not compatible with overly aggressive chemical products

Temperature range: -50°C to +200°C (-58°F to +392°F)

Maximum pressure when used for steam: 12 bars/ 174 psi.

Maximum manufacturing length: 4.00 meters (13').



Inner diameter (inch)	Inner diameter (mm)	Outer diameter on the braiding (mm)	Tube total outer diameter (mm)	Bending radius mm ISO 1746/1983	Working pressure		Bursting pressure	
					*(bar) @ 20°C ISO 1402/1994	psi @ 68°F	*(bar) @ 20°C ISO 1402/1994	psi @ 68°F
3/16	4.76	8	18	35	200		600	
1/4	6.35	10	18	50	180		480	
5/16	7.95	11	19	60	150		450	
3/8	9.5	13.2	22	90	130		390	
1/2	12.7	16.1	24	100	100		300	
5/8	15.8	20	28	120	90		270	
3/4	19.05	23.1	31	150	70		210	
1	25.4	29.2	39	250	60		180	

VENA BUTYLFLEXIBLE

Characteristics:

- Rubber tubes manufactured with food grade Butyl in accordance with FDA 21 CFR 177.2600.
- Equipped with textile reinforcements inside the wall of the tube, with 304 L double stainless steel spring wire and copper braiding to ensure an equipotent joint with the metal fittings and to protect from discharges of static electricity.
- Tubes with strong, durable construction that can withstand excessive physical handling.
- Operable with pressure or vacuum.
- **Inner appearance:** White, smooth.
- **Outer appearance:** Violet, smooth. Includes white information strip.
- **Operating pressure:** 10 bars/ 145 psi (all diameters)
- **Bursting pressure:** 30 bars/ 435 psi (all diameters)
- **Maximum operating temperature:** -30°C to +120°C (-22°F to +248°F)
- **Sterilization temperature:** 150°C (302°F)
Can be sterilized on-site by major Cleaning in Place (CIP) products.



- **Maximum manufacturing length:** 40 meters

- **Major Applications:** The Butylflexible tube is recommended for all types of food products, even at high temperatures (milk, chocolate, drinking water, fruit juice, fresh cream, oil, cosmetic cream, alcohol, etc.)

Inner diameter (inch)	Inner diameter (mm)	Outer diameter (mm)	Bending radius (mm)	Working pressure		Bursting pressure	
				*(bar) @ 20°C ISO 1402/1994	psi @ 68°F	*(bar) @ 20°C ISO 1402/1994	psi @ 68°F
5/8	15.8		40	10	145	30	435
3/4	19.05		45	10	145	30	435
1	25.4	37	50	10	145	30	435
1 1/4	31.7	45	60	10	145	30	435
1 1/2	38.1	51	65	10	145	30	435
2	50.8	65	85	10	145	30	435
2 1/2	63.5	78	130	10	145	30	435
3	76.2	92	220	10	145	30	435
4	101.6	120	320	10	145	30	435

PROTECTION OF FITTINGS

VENAIR Technosil offers supplementary protection devices for its entire product line in order to increase service life.

SILICONE SHEATHING FOR STAINLESS STEEL BEND PIPES (ELBOWS)

Handling pipes that were recently sterilized at high temperatures can cause burns when handled improperly. These can be covered with silicone to provide further protection.



When safety is a concern, the fastening clamp can also be covered with silicone protection.

Fields of application:

These operations can be performed on flexible tubes equipped with a metal fitting flexed at 90° assembled on each end by a special weld.



ANTI-SHOCK STOPS

Used with flexible tubes equipped with metal fittings in order to prevent damage or deformation caused by excessive contact.



METAL FITTINGS

SZR*SYSTEM (without Retention Zone)

The concept of the SZR system for flexible tubes produced by **VENAIR Technosil** has been fully researched. This system ensures that the tubes equipped with metal fittings on both ends satisfy even the most demanding requirements of the food, pharmaceutical, cosmetics, and chemical market, since all areas where contamination may occur between the joint of the tube and the fitting are eliminated by placing them at the same level.

The SZR system is designed to prevent the utmost differences in diameter between the metal fitting and the tube, ensuring continuous product flow without inner turbulence. This leads to time savings by allowing on-site cleaning (CIP) to be performed without disassembly. The SZR assembly system ensures a higher level of non-retention in the flexible tubes, as well as greater safety of use. All connections are manufactured in a single block, without welds.

The flexed 45° or 90° connections are secured by an orbital weld. It is not recommended the use of flexed metallic fittings assembled directly on the flexible tube. When the flexible tube has deteriorated, the terminal can not be recovered. We do recommend the use of adaptors especially designed for this purpose, whenever possible. They can be recovered, since they do not form an integral part of the flexible tube.

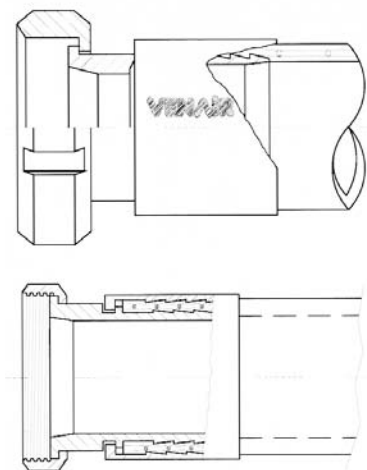

QUALITY OF FINISH

The roughness of the inner surface of the SZR fittings is weak and can be improved on request. The lot number for the raw material used in manufacture is indicated on each fitting.

After coupling, the final finish of the connections can be polished.

The year and the month of manufacture of the tube are engraved on one of the fittings in order to ensure its traceability.

Bending radius in compliance with ISO 1746/1983 Standards.

STAINLESS STEEL FITTINGS

straight tri-clamp				
A		B and C		Part Number
(mm)	(in.)	(mm)	(in.)	
25	1/2	6.35	1/4	021277100625
25	3/4	6.35	1/4	021277160625
25	1/2	9.52	3/8	021277101025
25	3/4	9.52	3/8	021277161025
25	1/2	12.7	1/2	021277101325
25	3/4	12.7	1/2	021277161325
25	1/2	19.05	3/4	021277101925
25	3/4	19.05	3/4	021277161925
50	1	6.35	1/4	021277220650
50	1 1/2	6.35	1/4	021277350650
50	1	9.52	3/8	021277221050
50	1 1/2	9.52	3/8	021277351050
50	1	12.7	1/2	021277221250
50	1 1/2	12.7	1/2	021277351250
50	1	19.05	3/4	021277221950
50	1 1/2	19.05	3/4	021277351950
50	1	25.4	1	021277222550
50	1 1/2	25.4	1	021277352550
64	2	25.4	1	021277482564
50	1 1/2	38.10	1 1/2	021277353850
64	2	38.10	1 1/2	021277483864
64	2	50.8	2	021277485064
77	2 1/2	50.8	2	021277605077
77	2 1/2	63.5	2 1/2	021277606377
91	3	63.5	2	021277736391
91	3	76.2	3	021277737691
119	4	101.6	4	02127798102119

DIN 11851							
DN	MALE		Part Number	FEMALE		Part Number	C (inch)
	A (mm)	B (mm)		A (mm)	B (mm)		
10	10	27.8	021100001010	10	25.4	021000001010	3/8
15	16	33.5	021100001516	16	31.6	021000001516	5/8
20	20	44	021100002020	20	40.4	021000002020	3/4
25	26	52	021100002525	26	48.7	021000002525	1
32	32	58	021100003232	32	54.5	021000003232	1 1/4
40	38	65	021100003840	38	61.6	021000003840	1 1/2
50	50	76	021100005050	50	74.3	021000005050	2
65	66	95	021100006365	66	91.5	021000006365	2 1/2
80	81	110	021100007580	81	105	021000007580	3
100	100	130	021100102100	100	125	021000102100	4
125	125	160	021100127125	125	154	021000127125	5
150	150	190	021100150152	150	185	021000150152	6

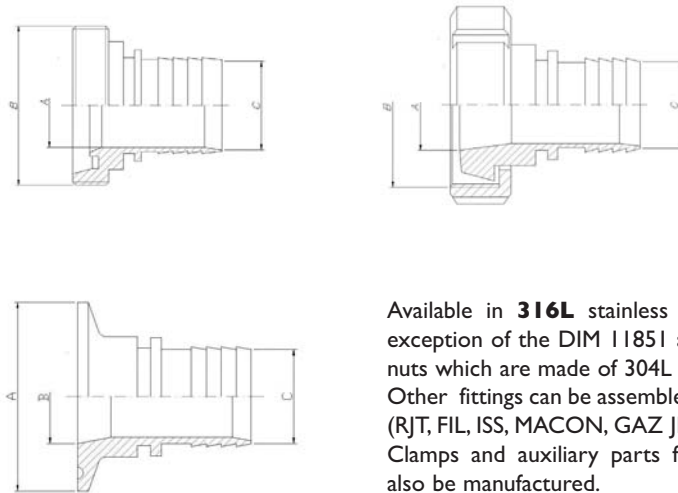

Available in **316L** stainless steel, with the exception of the DIM 11851 and SMS female nuts which are made of 304L stainless steel. Other fittings can be assembled upon request (RJT, FIL, ISS, MACON, GAZ JIC, flanges). Clamps and auxiliary parts for welding can also be manufactured.

SMS							
DN	MALE			FEMALE			C for both (inches)
	A (mm)	B (mm)	Part Number	A (mm)	B (mm)	Part Number	
25	22.5	40	021400002525	22.5	36.5	021300002525	1
38	35.5	60	021400003838	35.5	56.5	021300003838	1 1/2
51	48.5	70	021400005051	48.5	66.5	021300005051	2
63	60.5	85	021400006363	60.5	82	021300006363	2 1/2
76	72.8	98	021400007576	72.8	95	021300007576	3
104	100	125	021400102104	100	120	021300102104	4



45° and 90° Tri-Clamp Elbows						
A (mm)	(inch)	B (mm)	(inch)	Part Number 45° Elbow	Part Number 90° Elbow	C for both (inches)
25	1/2	6.35	1/4	021279101025	021278101025	3/8
50	1	25.4	1	021279222550	021278222550	1
50	1 1/2	38.10	1 1/2	021279353850	021278353850	1 1/2
64	2	50.8	2	021279485064	021278485064	2
77	2 1/2	63.5	2 1/2	021279806377	021278806377	2 1/2
91	3	76.2	3	021279737691	021278737691	3
119	4	101.6	4	02127998102119	02127898102119	4

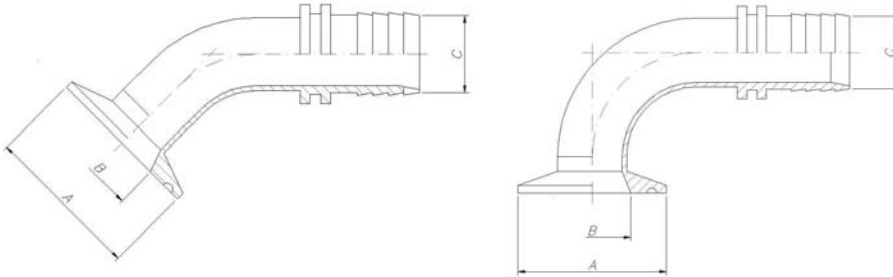

This range is available in a version pressed to the tube with the SZR System or as the recoverable VENA LOCK version (Recovery Without Retention Zone).

Each 316L stainless steel fitting includes the lot number of the raw material used for manufacture.

The internal roughness of each fitting can be improved upon request.

Male JIC x Male NPTF Adaptor		
A Male JIC	B Male NPT	Part Number
7/16	1/4	21534700613
1/2	1/4	21534700813
3/4	3/8	21534701217
7/8	1/2	21534701621
1 1/16	3/4	21534702026
1 5/16	1	21534702533
1 5/8	1 1/4	21534703242
1 7/8	1 1/2	21534703848

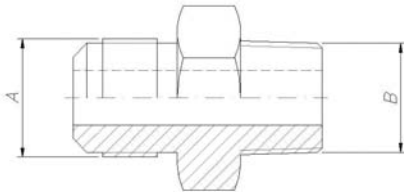

Female JIC Straight Insert			
A Female JIC	B Ø For Hose		Part Number
	(inch)	(mm)	
7/16	1/4	6.35	21564600671
1/2	1/4	6.35	21564600804
3/4	3/8	9.52	21564601206
7/8	1/2	12.7	21564601408
1 1/16	3/4	19.05	21564601712
1 5/16	1	25.4	21564602515
1 5/8	1 1/4	31.75	21564602620
1 7/8	1 1/2	38.10	21564603024

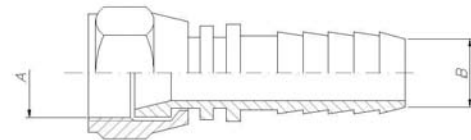

Male JIC x Female NPTF Adaptor		
A Male JIC	B Male NPT	Part Number
7/16	1/4	21550000613
1/2	1/4	21550000813
3/4	3/8	21550001217
7/8	1/2	21550001621
1 1/16	3/4	21550002026
1 5/16	1	21550002533
1 5/8	1 1/4	21550003242
1 7/8	1 1/2	21550003848

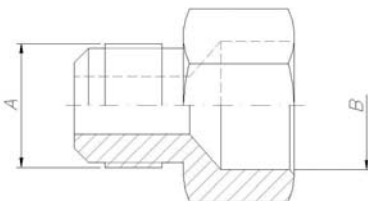

Female JIC Elbow 45° Insert			
A Female JIC	B Ø For Hose		Part Number
	(inch)	(mm)	
7/16	1/4	6.35	21564610704
1/2	1/4	6.35	21564610804
3/4	3/8	9.52	21564611206
7/8	1/2	12.7	21564611408
1 1/16	3/4	19.05	21564611712
1 5/16	1	25.4	21564612116
1 5/8	1 1/4	31.75	21564612620
1 7/8	1 1/2	38.10	21564613024

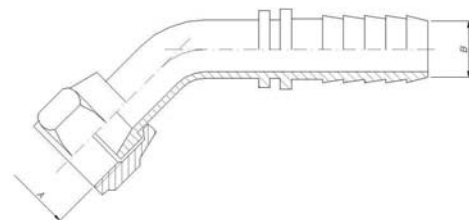

Available in 316L stainless steel, with the exception of the DIM 11851 and SMS female nuts which are made of 304L stainless steel. Other fittings can be assembled upon request (RJ, FIL, ISS, MACON, GAZ JIC, flanges). Clamps and auxiliary parts for welding can also be manufactured.

Insert Female JIC Elbow 90°			
A	B Ø For Hose		Part Number
Female JIC	(inch)	(mm)	
7/16	1/4	6.35	21574600671
1/2	1/4	6.35	21574600804
3/4	3/8	9.52	21574601206
7/8	1/2	12.7	21574601408
1 1/16	3/4	19.05	21574601712
1 5/16	1	25.4	21574602116
1 5/8	1 1/4	31.75	21574602620
1 7/8	1 1/2	38.10	21574603024

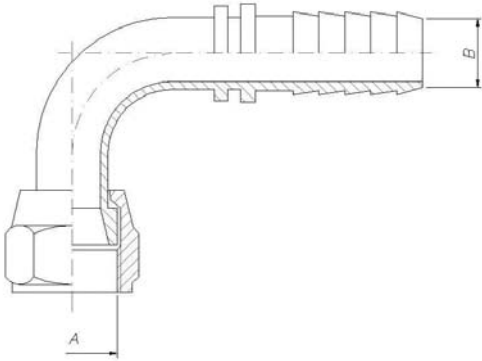

Ferrules			
Inside Diameter		For Hose	Part Number
(inch)	(mm)		
1/4	6.35	650V – Technosil 655 - 640	022000450006
5/16	7.93	650V – Technosil 655 - 640	022000450008
3/8	9.52	650V – Technosil 655 - 640	022000450010
1/2	12.7	650V – Technosil 655 - 640	022000450012
5/8	15.8	650V – Technosil 655 - 640	022000450016
3/4	19.05	650V – Technosil 655 - 640	022000450019
1	25.4	650V – Technosil 655 - 640	022000450025
1 1/4	31.75	650V – Technosil 640	022000450032
1 1/2	38.10	650V – 640	022000450038
2	50.8	650V – 640	022000450050
2 1/2	63.5	650V – 640	022000450063
3	76.2	650V – 640	022000450076
4	101.6	650V – 640	022000450102
1 1/4	31.75	655 – Butylfood	022000455032
1 1/2	38.10	655 – Butylfood	022000455038
2	50.8	655 – Butylfood	022000455050
2 1/2	63.5	655 – Butylfood	022000455063
3	76.2	655 – Butylfood	022000455076
4	101.6	655 – Butylfood	022000455102

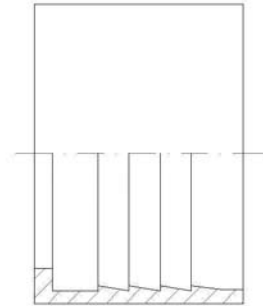

Insert Male NPT			
A	B Ø For Hose		Part Number
Male NPT	(inch)	(mm)	
1/8	1/4	6.35	21534650204
1/4	1/4	6.35	21534650404
3/8	3/8	9.52	21534650606
1/2	1/2	12.7	21534650808
3/4	3/4	19.05	21534651212
1	1	25.4	21534651616
1 1/4	1 1/4	31.75	21534652020
1 1/2	1 1/2	38.10	21534652424

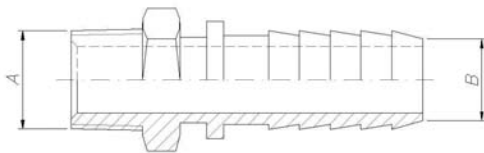

REFERENCES

VENAIR Technosil's reputation as a worldwide leader in flexible silicone tubes has caught the attention of some of the most well-known brands across many sectors:

FOOD

DANONE
NESTLE
SCHWEPPES
COCA COLA
KRONENBOURG

PHARMACEUTICAL

PFIZER
GLAXO-WELLCOME
AVENTIS
MILLIPORE
SCHERING-PLOUGH

COSMETICS

L'OREAL
NIVEA
ROC
LANCASTER

CHEMICAL

RHONE POULENC
BAYER
HENKEL

PRECAUTIONS FOR USE

All flexible tubes must be sterilized prior to use and should be used only for the purpose they were designed for.

All **TechnoSil** tubes can be sterilized by hot air at +250°C (+482°F) or by steam at +135°C (+275°F), with a pressure of 3.5 bars.

Maximum recommended time: 1 hr 30 m. at +135°C (+275°F).

A time interval of at least 1 hour between successive sterilizations must be observed so that the tube can properly stabilize.

Steam alters the mechanical and volumetric properties of the silicone elastomer. A careful examination the tube is recommended after 150 hours of steam sterilization. If the recommended sterilization time is surpassed, they may suffer the effects of hydrolysis.

VENAIR Technosil is not responsible for improper use of the tubes. Failure to comply with these precautions for use may result in unfavorable conditions. Cleaning products such as caustic soda and 5% nitric acid solution do not alter product quality. Information should be provided on the maximum pH the tubes will be required to withstand, as well as the fluid to be conveyed and the operating temperature. The silicone tubes are not recommended for transport of abrasive products.

If the tube is run over, even if it is not equipped with a spring steel wire, the textile components that form the tube may become unraveled due to the pressure. Sudden bursts of pressure may damage the tubes. The pressure and temperature should be as indicated for use of the tube. Ensure that there is no hammering during the process that may affect the duration of the tube. (Hammering can lead to a ten-fold increase in the operating pressure initially foreseen.)

A flexible tube is not a sling. Do not try to use the flexible tube to drag a machine with wheels. Avoid dragging tubes on the ground.

If the tubes are temporarily not in use, they should be stored on a shelf in a clean, dry place, protected from light and ozone. In order to prevent unnecessary reactions, the shelf should not be made of sulphurized steel.

On connection boards, flexed adaptors of either 45° or 90° should be used in order to prevent excessive tube curvature.

Ensure that the flexible tube used is chemically compatible with the product.

The tube is a living component that is in movement. Proper care of these tubes will ensure that the investment is cost-effective. Our flexible tubes have a service life between 10 to 20 times greater than that of conventional tubes

GUIDE TO GOOD PRACTICES FOR CHOICE, STORAGE, USE, AND MAINTENANCE

This document is meant to ensure that users of flexible, elastic tubes made of rubber or plastic materials can obtain optimum duration, taking into account different conditions of use.

PURPOSE AND FIELD OF APPLICATION

This document provides recommendations for users of rubber or plastic flexible tubes that facilitate maintaining these articles in conditions similar to those existing when they were supplied after they begin operation, and to obtain an optimum duration of service life taking into account these conditions of use.

This Guide to Good Practices includes two parts:

PART A: GENERAL RECOMMENDATIONS

Section 1- Criteria for choice of tube

Section 2- Storage conditions

Section 3- Rules for use and maintenance

PART B: SUPPLEMENTARY RECOMMENDATIONS FOR SPECIFIC APPLICATIONS

Section 1- Steam

Section 2- Food and food products

Section 3- Abrasive products

Section 4- Corrosive and aggressive products

Section 5- Inflammable products

PART A: GENERAL RECOMMENDATIONS

I CRITERIA FOR CHOICE OF TUBE

I.1 In order to choose a flexible tube that is suitable for a specific use, the following points should be taken into account:

I.1.1 Pressure- Negative Pressure

- Operating pressure and negative pressure values.
- Value of possible overloads (hammering).

I.1.2. Products transported

Form: liquid, gas, or solid. In solids: granulated, density, performance of solid product transported, type, speed of passage, and flow volume transported.

- Frequency of use.
- Type, designation, concentration, operating temperature.

I.1.3. Environment

- Location of use, ambient temperature, hygrometric grade, possible exposure to atmospheric agents or ozone.
- Products that may come into contact with the end of the flexible tube.

I.1.4. Mechanical limitations

- Minimum bending radius for operation.
- Possible limitations in terms of traction, torsion, flexion, vibration, or compression.
- Risk of shock, abrasion, corrosion.
- Operating position: on the floor, hanging, or submerged.

I.1.5. Connection used or planned

- Connection: type, size, and type of thread.
- Manifolds: outer and inner diameter.
- Length of adjustment.
- Type and size of bands.
- Type of outer fastening.

I.1.6. Specific Conditions

Users to choose flexible tubes that comply with the standards in their country, whenever such standards have been established within the planned field of application.

- Requirements for specific markings.
- Application of regulations, standards, or specifications in force.

II STORAGE CONDITIONS

II.1 General

Since flexible tubes are exposed to different factors during the period of use, they undergo changes to their physical properties. Therefore, when the time comes to begin operation, they may not be in suitable condition. The general storage conditions required to prevent deterioration of the products stored are described in the following:

II.2 Duration of Storage

Whenever possible, the duration of storage period should be reduced; for such purposes, it is essential to ensure rotation of stocks based on "first in, first out" criteria. When prolonged storage is required, for periods such as one year, an in-depth examination of the product must be performed before beginning operation.

II.3 Temperatures and Humidity

Whenever possible, the storage temperature should range between 0°C/ 32°F and 35°C/ 95°F (optimum temperature 15°C/ 59°F). The relative humidity should not be above 65%.

II.4 Light

The articles should be stored in dark premises, protected from sunlight and intense artificial lighting. If there are windows or glass openings in the storage premises, these should be covered with red, orange, or white paint.

II.5 Ozone

Due to the harmful effects of ozone on rubber articles, there should not be any materials in the storage areas that can produce ozone, such as mercury vapor lamps or tubes, high voltage electrical equipment, electrical motors, or other materials that may cause sparks or electrical discharges.

II.6 Environment

Tubes and flexible tubes should not come into contact with products nor be exposed to any vapors such as solvents, fuel, oil, grease, volatile components, acid, disinfectants, etc. Moreover, materials such as copper, iron, or manganese cause harmful effects for some rubber blends.

II.7 Source of heat

There should be sufficient distance between the sources of heat (heating devices, for example) and the articles stored so that it will remain within the temperature limits defined in paragraph 2.3. If this is not possible, a heat shield should be used.

II.8 Electrical or magnetic field

Variations in the electrical or magnetic field in the storage premises should be prevented, since this may lead to current in the metal fittings which would be heated. Such fields can be caused by high voltage power lines or high frequency generators.

II.9 Storage Conditions

Flexible tubes should be stored without limitations, elongation, or excessive deformation.

Any contact with sharp or cutting material or objects should be prevented. They should be stored on dry surfaces and, whenever possible, storage compartments should be provided. The flexible tubes wound up in a crown shape should be stored flat and preferable not stacked on top of one another. If this cannot be avoided, the height of the piles should be limited to ensure there are not any permanent deformations in the articles located on the lower part. Place the heavier articles in the lower area and reserve the higher area for the lighter articles. The winding should be at least equal to the minimum bending radius specified by the manufacturer or the product standard. Hanging the crowns on spikes or hooks is not recommended. Tubes that are supplied in straight lengths should be stored flat and without folds.

II.10 Rodents

The flexible tubes should be protected from rodents. If there is any risk, the appropriate precautions should be taken.

II.11 Release from warehouse

Precautions must be taken to ensure that the tubes requested are in flawless condition and suitable for the planned use. Therefore, identification of the different tubes stored is essential. Moreover, in specific cases in which flexible tubes have been stored for extended periods of time, satisfactory adjustment of the metal fittings must be verified.

II.12 Return to the warehouse

Before returning them to the warehouse, the tubes that are taken out of service should be emptied of the substances they have conveyed. Special care should be taken if the tubes have transported chemical products, explosives, inflammable, or corrosive products. After cleaning, prior to storage, the satisfactory condition and fitness of the tubes must be verified in order to ensure future use.

II.13 Cleaning

Cleaning with brushes, sponges, or baizes should be performed with soap and water or detergents made from surfactant products. Metal brushes,

abrasive, pointed, or cutting instruments should not be used, and use of solvents should be avoided.

III RULES FOR USE

III.1 Maintenance

The flexible tubes should always be handled with a minimum of precautions. For example, they should not be dragged on sharp or abrasive surfaces, subject to shocks, cutting, deformation, or run over by vehicles.

Suitable transport should be provided for the heavy flexible tubes supplied in straight lengths, especially when lifted.

III.2 Sealing Test

After the metal fittings have been assembled, a hydraulic test under pressure is recommended to ensure that they are in satisfactory condition (no leaks or slippage of the fittings with the tube). If it has not been established by the regulatory test or standards, the value for the pressure test is usually indicated by the tube manufacturer.

III.3 Elimination of static electricity

When the requirements for electric continuity must be taken into account, the recommendations for assembly furnished by the manufacturer should be followed closely. Moreover, after installation of the fittings, a test should be performed. If the tube has very low resistance, this test should be performed by simplified equipment (for example, a "quick test"). In other cases, an insulation controller is required.

III.4 Fixed installations

When possible, the flexible tubes used in fixed installations should be joined by the appropriate securing device. This device should not interfere with the normal variations in flexible tubes subject to pressure such as length, diameter, and/or torsion. If the tubes must be used under special conditions in terms of mechanical behavior; pressure, vacuum, or geometry, consult the manufacturer.

III.5 Moving parts

When the flexible tubes are installed on moveable parts, ensure that the tube is not subject to shocks, blocking, or friction due to movement, and that it is not forced to undergo abnormal curvature, folding, traction, or torsion.

III.6 References

If not only marking, but also a reference is required on the flexible tube, adhesive tape rings should preferably be used. If this is not possible, avoid the use of paint. Consult the manufacturer of the flexible tube, since the tube sheathing is not compatible with the solvents used in the painting industry.

III.7 Maintenance

Although there are some fields of use in which there are specific regulations, controls should be performed on all flexible tubes on a regular basis to ensure their fitness for continuing operation. It is especially necessary to consider the condition of the fittings and the appearance of certain anomalies that indicate the tube has deteriorated, either due to normal aging or aggressions related to improper conditions of use or accidents during maintenance.

Therefore, special care should be taken to watch out for the appearance of:

- Fissures, scratches, cleavage, or ruptures in the sheathing that lead to exposure of its framework;
- Deformation, blisters, or localized swelling when they are subject to pressure;
- Leaks.

If these anomalies are detected, the flexible tube should be replaced. Moreover, in certain fields of use, an expiration date has been established for safety reasons. This date is indicated on the marking of the flexible tube, and it should be respected even if the tube does not show apparent signs of expiration.

III.8 Repairs

In general, repair of the tubes is not recommended. Nevertheless, in specific cases when possible repair is considered, this must be limited strictly to the manufacturer's recommendations for the tubes. Moreover, following repair, a pressure test should be performed. If there is deterioration due to a cut on one end, and the length of the tube that is still in good condition is sufficient, the tube can be repaired by cutting off the defective part.

PART B: SUPPLEMENTARY RECOMMENDATIONS FOR SPECIFIC APPLICATIONS

I STEAM

In addition to the general recommendations furnished in Part A, there are some specific points that must be described in detail.

I.1 Criteria for choice of tube

The tubes included in the manufacturer's catalogs are generally planned for transport of wet steam. In this case, there is a direct relationship between temperature and pressure. When overheated steam or water are conveyed, consult the manufacturer of these tubes as in such cases there is no direct relationship between temperature and pressure, and the tube must withstand different conditions. Moreover, if operation is not continuous or there are cooling phases in the operation cycle, the tube is subject to thermal shocks that can lead to a phenomenon known as "popcorning".

POPCORNING:

It must be taken into account that the steam is diffused through the walls of the tube. This explains why the steam tubes are usually constructed with a sheathing that has been marked off to facilitate diffusion and thus prevent the development of ruptures in the sheathing.

- Development of phenomenon:

If circulation of the steam is interrupted or the temperature or condensation decreases during the cooling phase, then the pressure inside the tube decreases.

If the temperature rises, the water evaporates again, leading to increased pressure. Due to the ongoing effect of these thermal shocks, swelling and localized explosions may develop in the tube. Since they resemble the bursting of grains of corn, this phenomenon is often referred to as "popcorning".

I.2 Installation

Depending on the operating temperature, suitable measures and technical precautions should be implemented in order to protect the personnel and prevent the consequences of an accidental explosion of the flexible tube.

II FOOD AND FOOD PRODUCTS

In this field of use, the flexible tubes are generally subject to the regulatory requirements based on the type of components and the chemical inertia that occurs depending on the products to be conveyed. Therefore, it is necessary to ensure that the flexible tubes comply with these requirements. Moreover, the regulations often require standards for cleaning and sterilization of flexible tubes. The user is fully responsible for the type of cleaning products as well as the frequency of cleaning.

III ABRASIVE PRODUCTS

For optimum duration, the flexible tubes should be maintained as straight as possible and unnecessary curves should be avoided. Therefore, larger bending radiuses must be used since, if the radius is too small, it will cause undesirable turbulence inside the tube. Moreover, it is necessary to control the electrical conductivity that, in this kind of tube, is ensured by an effective disposal of the loads of static electricity generated by the friction of the particles conveyed against the wall of the tube.

As for the fittings, the outer ones should not be subject to abrasion. Moreover, the joints in the tubes prevent the formation of turbulence which, as mentioned previously, leads to high consumption in unsuitable conditions.

IV CORROSIVE OR AGGRESSIVE PRODUCTS

These include acids, bases, solvents, agricultural, and pharmaceutical products as well as other chemical products. Whenever the products are not included in the list of compatible products furnished with the technical documentation, or the temperature and concentration limits are not within the acceptable parameters, the tube manufacturer should be consulted. Stagnation of fluids inside the flexible tubes, particularly solutions or emulsions, should be prevented, since the resulting decantation leads to concentrations that may surpass the permissible limits. In order to prevent this, the tubes should be cleaned and rinsed after each use, as described in paragraph 3.4 or Part A. It is particularly important to take all necessary technical precautions in order to prevent leaks caused by accidental explosion of the flexible tubes.

V INFLAMMABLE PRODUCTS

Such products include liquid hydrocarbons (essences, petroleum, kerosene) or gaseous hydrocarbons (GPL). In most countries, there are regulations for storage and transport of these products. In the field of flexible tubes, the regulatory requirements regarding electrical resistance should be complied with. Moreover, it is important to consider the type and frequency of controls required to ensure their fitness for use with the passing of time. For the hydrocarbons, it should also be ensured that the percentage of aromatic hydrocarbons (benzene, toluene, xylene) is within the limits established by the manufacturer of flexible tubes.

RECOMMENDED AND NOT RECOMMENDED BENDING RADIUS

For flexible tubes

Recommended

Not Recommended

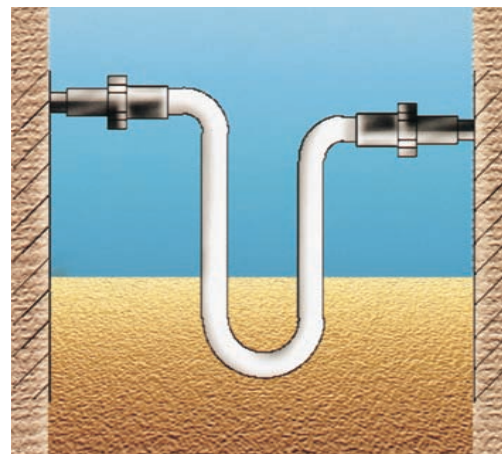
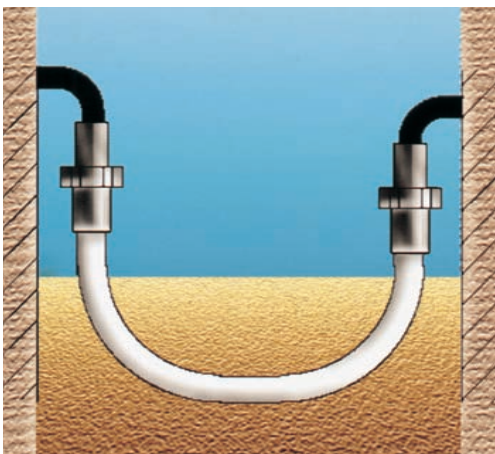
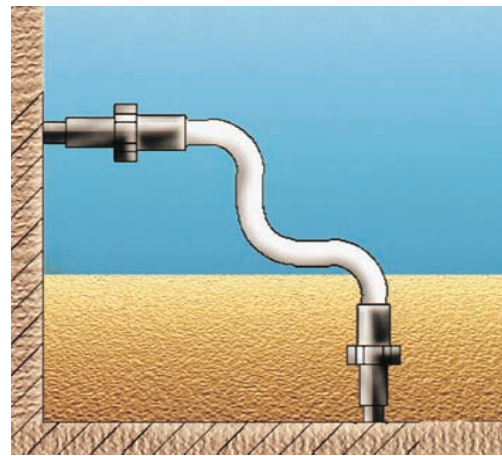
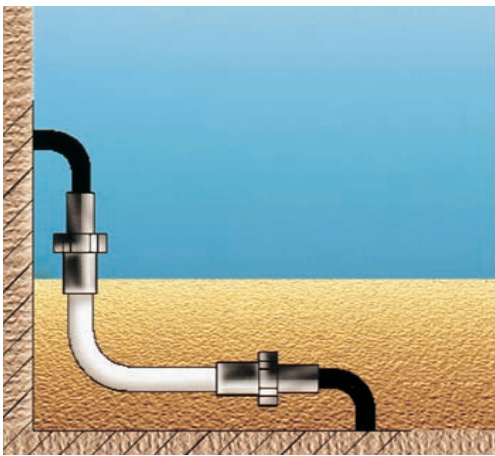
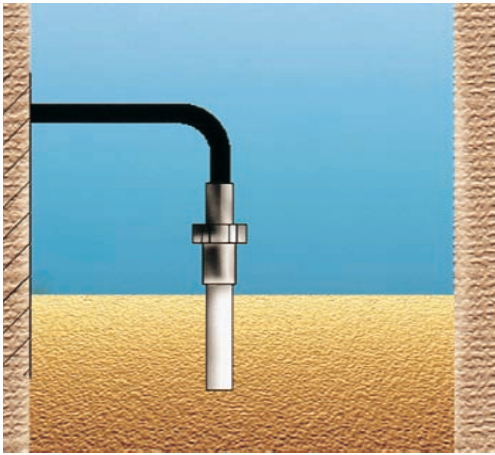

Resistance to different products:

A - excellent
B - good
C - insufficient
D - unsatisfactory
E - please, consult

	S	F	B	V	P
	I	L	U	T	T
	L	O	T	O	S
	C	S	I	S	I
	O	I	L	I	L
	N	L	L	L	L
	E	L	L	L	L
butyric acid	E	E	B	B	A
C					
calceine liquors	E	A	A	A	A
calcium acetate	D	D	A	D	A
calcium bisulfite	A	A	D	A	A
calcium carbonate	A	A	A	A	A
calcium chloride	A	A	A	A	A
calcium cyanide	A	E	A	E	A
calcium hydroxide	A	A	A	A	A
calcium hypochloride	E	A	A	A	A
calcium hypochlorite	B	B	A	A	A
calcium nitrate	B	A	A	A	A
calcium phosphate	A	E	A	A	A
calcium salts	B	A	A	A	A
calcium silicate	E	E	A	A	A
calcium sulfide	B	A	A	A	A
calcium sulfite	A	A	A	A	A
calcium thiosulfate	A	A	A	A	A
caliche liquors	B	A	A	A	A
cane sugar liquors	A	A	A	A	A
caproic aldehyde	B	D	B	D	A
carbanate	E	A	B	A	A
carbitol	B	B	B	B	A
carbolic acid	D	A	B	A	A
carbon bisulfide	E	A	D	A	A
carbon dioxide, dry	B	B	B	B	A
carbon dioxide, wet	B	B	B	B	A
carbon disulfide	E	A	D	A	A
carbon monoxide	A	B	A	A	A
carbon tetrachloride	D	A	D	A	A
carbonic acid	A	A	A	A	A
castor oil	A	A	B	A	A
cellosolve	D	D	B	D	A
cellosolve acetate	D	D	B	D	A
cellosolve butyl	D	D	B	D	A
celluguard	A	A	A	A	A
cellulube A60 (now fyrquel)	E	C	A	B	A
cellulube 90,100,150,220, 300 and 500	A	B	A	A	A
cellutherm 2505A	E	B	D	A	A
cetate (hexadecane)	D	C	D	A	A
china wood oil (tung oil)	D	B	C	A	A
chloroacetic acid	E	D	B	D	A
chlorodane	D	B	D	A	A
chlortexol	D	B	D	A	A
chlorinated salt brine	D	A	D	A	A
chlorinated solvents, dry	D	A	D	A	A
chlorinated solvents, wet	D	A	D	A	A
chlorine, dry	D	A	D	A	A
chlorine, wet	E	B	C	A	A
chlorine dioxide	E	B	C	A	A
chlorine dioxide (8%Cl as NAC102 in solution	E	B	D	A	A
chlorine trifluoride	D	B	D	D	A
chloroacetone	D	D	A	D	A
chloroacetic acid	E	E	B	E	A
chlorobenzene	D	B	D	A	A

chlorobenzene (mono)	D	B	D	A	A
chlorobromo methane	D	B	B	B	A
chlorobutadiene	D	B	D	A	A
chlorododecane	D	A	D	A	A
chloroform	D	B	D	A	A
O-chloroaphtanene	D	B	D	A	A
l-chloro- l-nitro ethane	D	D	D	C	A
chlorosulfonic acid	D	D	D	C	A
chlorotoluene	D	B	D	A	A
chlorox	E	A	B	A	A
O-chlorphenol	D	B	D	A	A
chrome alum	A	E	A	A	A
chrome plating solution	B	B	D	A	A
chromic acid	C	C	C	A	A
chromic oxide 88 Wt, % aqueous solution	B	B	B	A	A
circo light process oil	D	A	D	A	A
citric acid	A	A	A	A	A
city service koolmotor-AP gear oil 140 E, P,Lube	D	A	D	A	A
city service pacemaker #2	D	A	D	A	A
city service #65, #120, #250	D	A	D	A	A
cobalt chloride	B	A	A	A	A
cobalt chloride, 2N	A	A	A	A	A
cocaoan oil	A	A	C	A	A
cod liver oil	B	A	A	A	A
coffee	A	A	A	A	A
coke oven gas	B	B	D	A	A
coliche liquors	E	E	B	E	A
convelex 10	D	E	E	E	A
coolanol (monsanto)	D	B	D	A	A
coolanol 45 (monsanto) +A269	D	B	D	A	A
copper acetate	D	D	A	D	A
copper chloride	A	A	A	A	A
copper cyanide	A	A	A	A	A
copper salts	A	A	A	A	A
copper sulfate	A	A	B	A	A
copper sulfate 10%	A	A	B	A	A
copper sulfate 50%	A	A	B	A	A
corn oil	A	A	C	A	A
cottonseed oil	A	A	C	A	A
creosols	D	B	D	A	A
creosote	D	C	D	A	A
creosote, coal tar	D	A	D	A	A
creosote, wood	D	A	D	A	A
creosylic acid	D	B	D	A	A
crude oil	D	B	D	A	A
cumene	D	B	D	A	A
cutting oil	D	A	D	A	A
cyclohexane	D	A	D	A	A
cyclohexanol	D	A	D	A	A
cyclohexanone	D	D	B	D	A
P-cymene	D	B	D	A	A
D					
decalin	D	A	D	A	A
decane	B	A	D	A	A
delco brake fluid	C	D	A	D	A
denatured alcohol	A	A	A	A	A
detergent solutions	A	A	A	A	A
developing fluids (photo)	A	A	B	A	A
dextron	D	B	D	A	A
diacetone	D	D	A	D	A
diacetone alcohol	D	D	A	D	A
diazinon	D	B	D	B	A
dibenzyl ether	E	E	B	D	A
dibenzyl sebacate	C	C	B	B	A
dibromoethyl benzene	D	B	D	A	A
dibutylamine	C	D	D	D	A

dibutyl ether	D	C	C	C	A
dibutyl phthalate	B	C	C	B	A
dibutyl sebacate	B	B	B	B	A
O-dichlorobenzene	D	B	D	A	A
P-dichlorobenzene	D	E	D	E	A
dichloro-butane	D	B	D	A	A
dichloro-isopropyl ether	D	C	C	C	A
dicyclohexylamine	E	D	D	D	A
diesel oil	D	A	D	A	A
di-ester lubricant MIL-L-7808	D	B	D	A	A
di-ester synthetic lubricants	D	B	D	A	A
diethylamine	B	D	B	D	A
diethyl benzene	D	C	D	A	A
diethyl ether	D	C	D	D	A
diethyl sebacate	B	B	B	B	A
diethylene glycol	B	B	A	A	A
difluorodibromomethane	D	E	B	E	A
diisobutylene	D	C	D	A	A
diisooctyl sebacate	C	C	C	B	A
diisopropyl benzene	E	B	D	A	A
diisopropyl ketone	D	D	A	D	A
dimethyl aniline	E	D	B	D	A
dimethyl formamide	B	D	B	D	A
dimethyl phthalate	E	B	B	B	A
dinitro toluene	D	D	D	D	A
dioctyl phthalate	C	B	B	B	A
dioctyl sebacate	C	C	B	B	A
dioxane	D	D	B	D	A
dioxolane	D	D	B	D	A
dipentene	A	D	D	A	A
diphenyl	D	B	D	A	A
diphenyl oxides	C	B	D	A	A
dow chemical 50-4	E	D	A	D	A
dow chemical ET378	D	E	E	E	A
dow chemical ET588	E	D	B	D	A
dow corning-3	C	A	A	A	A
dow corning-4	C	A	A	A	A
dow corning-5	C	A	A	A	A
dow corning-11	C	A	A	A	A
dow corning-33	C	A	A	A	A
dow corning-44	C	A	A	A	A
dow corning-55	C	A	A	A	A
dow corning-200	C	A	A	A	A
dow corning-220	C	A	A	A	A
dow corning-510	C	A	A	A	A
dow corning-550	C	A	A	A	A
dow corning-704	E	E	A	A	A
dow corning-705	E	E	A	A	A
dow corning-710	C	A	A	A	A
dow corning-1208	C	A	A	A	A
dow corning-4050	C	A	A	A	A
dow corning-6620	C	A	A	A	A
dow corning-F60	C	A	A	A	A
dow corning-F61	B	A	A	A	A
dow corning-F61	C	A	A	A	A
dow corning-XF60	C	A	A	A	A
dow guard	A	A	A	A	A
dowtherm oil	B	A	D	A	A
dowtherm A or E	D	B	D	A	A
dowtherm 209.50%solution	C	E	A	D	A
driking water	A	A	A	A	A
dry cleaning fluids	D	B	D	A	A
DTE light oil	D	A	D	A	A
E					
elco 28-EP lubricant	B	A	D	A	A
epichlorohydrin	D	D	B	D	A
epoxy resins	E	E	A	D	A
esam-6 fluid	E	D	A	D	A
esso fuel 208	B	A	D	A	A
esso golden gasoline	D	A	D	A	A

Resistance to different products:

A - excellent
B - good
C - insufficient
D - unsatisfactory
E - please, consult

	S I L I C O N E	F L U O O I L	B U T Y L F L O O D	V I T O I L	P T F S I L
esso motor oil	D	A	D	A	A
esso transmission fluid (typeA)	D	A	D	A	A
esso WS3812 (MIL-L-7808 A)	D	A	D	A	A
esso SP90-EP lubricant	D	A	D	A	A
esstic 42, 43	B	A	D	A	A
ethane	D	B	D	A	A
ethanol	A	C	A	A	A
ethanol amine	B	D	B	D	A
ethers	D	C	C	C	A
ethyl acetate-organic ester	B	D	B	D	A
ethyl acetoacetate	B	D	B	D	A
ethyl acrylate	B	D	B	D	A
ethyl acrylic acid	D	D	B	E	A
ethyl alcohol	B	A	A	A	A
ethyl benzene	D	A	D	A	A
ethyl benzoate	D	A	D	A	A
ethyl bromide	E	A	D	A	A
ethyl cellosolve	D	D	B	D	A
ethyl cellulose	C	D	B	D	A
ethyl chloride	D	A	A	A	A
ethyl chlorocarbonate	D	B	D	A	A
ethyl chloroformate	D	B	D	A	A
ethyl cyclopentane	D	A	D	A	A
ethyl ether	D	C	C	D	A
ethyl formate	E	A	B	A	A
ethyl hexanol	B	A	A	A	A
ethyl mercaptan	C	E	D	B	A
ethyl oxalate	D	B	D	A	A
ethyl pentachlorobenzene	D	B	D	A	A
ethyl silicate	E	A	A	A	A
ethylene	E	A	E	A	A
ethylene chloride	D	C	D	B	A
ethylene chlorohydrin	C	B	B	A	A
ethylene diamine	A	D	A	D	A
ethylene dibromide	D	C	C	A	A
ethylene dichloride	D	C	C	A	A
ethylene glycol	A	A	D	A	A
ethylene oxide	D	D	C	D	A
ethylene trichloride	D	C	C	A	A
ethylmorpholene stannous octoate (50/50 mixture)	E	E	B	D	A
F					
F-60 fluid (dow corning)	D	A	A	A	A
F-61 fluid (dow corning)	D	A	A	A	A
fatty acids	C	E	D	A	A
FC-43 hetacosofluorotri-butylamine	A	A	A	A	A
FC75 fluorocarbon	A	B	A	B	A
ferric chloride	B	A	A	A	A
ferric nitrate	C	A	A	A	A
ferric sulfate	B	A	A	A	A
fish oil	A	A	A	A	A
fluoboric acid	E	E	A	E	A
fluorine (liquid)	D	E	C	B	A
fluorobenzene	D	B	D	A	A

fluorocarbon oils	E	E	A	E	A
fluorolube	A	B	A	B	A
fluorinated cyclic ethers	E	E	A	E	A
fluosilicic acid	E	E	E	E	A
formaldehyde	B	D	A	D	A
formic acid	B	C	A	C	A
freon, 11	D	D	B	D	A
freon, 12	D	D	B	B	A
freon, 12 & ASTM-oil #2 (50/50 mixture)	D	B	D	A	A
freon, 12 & SUNISO 4G (50/50 mixture)	D	B	D	A	A
freon, 13	D	D	A	A	A
freon, 13B1	D	B	A	A	A
freon, 14	D	E	A	A	A
freon, 21	D	E	D	D	A
freon, 22	D	D	A	D	A
freon, 22 & ASTM OIL #2D (50/50 mixture)	B	D	B	A	
freon, 31	E	E	A	D	A
freon, 32	E	E	A	D	A
freon, 112	D	E	D	A	A
freon, 113	D	D	D	B	A
freon, 114	D	B	A	B	A
freon, 114B2	D	E	D	B	A
freon, 115	D	E	A	B	A
freon, 142b	E	E	A	D	A
freon, 152a	E	E	A	D	A
freon, 218	E	E	A	A	A
freon, C316	E	E	A	E	A
freon, C318	E	E	A	A	A
freon, 502	E	E	A	B	A
freon, BF	D	E	D	A	A
freon, MF	D	E	D	B	A
freon, TF	D	E	D	B	A
freon, TA	A	E	A	C	A
freon, TC	D	E	B	A	A
freon, TMC	C	E	B	A	A
freon, T-P35	A	E	A	A	A
freon, T-WVD602	D	E	B	A	A
freon, PCA	D	E	D	B	A
fuel oil	D	A	D	A	A
fuel oil acidic	A	A	D	A	A
fuel oil #6	A	A	D	A	A
fumaric acid	B	A	E	A	A
fuming sulphuric acid (20/25% oleum)	D	E	D	A	A
furan (fufuran)	E	E	C	E	A
furfural	D	E	B	D	A
furfuraldehyde	D	E	B	D	A
furfuraly alcohol	D	D	B	E	A
furyl carbinol	D	D	B	E	A
fyrquel A60	C	D	B	D	A
fyrquel 90, 100, 150, 220, 300, 500	A	B	A	A	A
G					
galic acid	E	A	B	A	A
gasoline	D	A	D	A	A
gelatin	A	A	A	A	A
grilling brake fluid	E	D	A	D	A
glacial acetic-acid	B	D	B	D	A
glauber's salt	E	A	B	B	A
glucose	A	A	A	A	A
glue (depending on type)	A	A	A	A	A
glycerine-glycerol	A	A	A	A	A
glycols	A	A	A	A	A
green sulphate liquor	A	B	A	A	A
gulfcrown grease	D	A	D	A	A
gulf endurance oils	D	A	D	A	A

gulf FR fluids (emulsion)	D	A	D	A	A
gulf FRG-fluids	A	A	A	A	A
gulf FRp-fluids	A	B	B	B	A
gulf harmony oils	D	A	D	A	A
gulf high temperature grease	D	A	D	A	A
gulf lesion oils	D	A	D	A	A
gulf paramount oils	D	A	D	A	A
gulf security oils	D	A	D	A	A
H					
halotane	D	B	D	A	A
halowax oil	D	A	D	A	A
hannifin lube A	B	A	D	A	A
heavy water	A	A	A	E	A
HEF-2 (high energy fuel)	D	B	D	A	A
helium	A	A	A	A	A
N-heptane	D	A	D	A	A
N-hexaldehyde	B	D	B	D	A
hexane	D	A	D	A	A
N-hexane-1	D	A	D	A	A
hexyl alcohol	B	B	C	A	A
high viscosity lubricant U14,	A	B	A	A	A
high viscosity lubricant H2,	A	B	A	A	A
hilo MS #1	C	C	B	D	A
houghto-safe271 (water and glycol base)	B	B	A	B	A
houghto-safe 620 (water/glycol)	B	B	A	B	A
houthto-safe 1010	C	B	A	A	A
phosphate ester	C	B	A	A	A
houghto-safe 1055	C	B	A	A	A
phosphate ester	C	B	A	A	A
houghto-safe 1120	C	B	A	A	A
phosphate ester	C	B	D	A	A
houghto-safe 5040 (water/oil emulsion)	C	B	D	A	A
hydraulic oil (petroleum base)	C	A	D	A	A
hydrazine	C	E	A	E	A
hydrobromic acid	D	A	A	C	A
hydrobromic acid 40%	D	C	A	A	A
hydrocarbons (saturated)	D	A	D	A	A
hydrochloric acid hot 37%	D	D	C	A	A
hydrochloric acid cold 37%	B	B	A	A	A
hydrochloric acid 3 molar	D	B	A	A	A
hydrochloric acid concentrated	D	C	C	A	A
hydrocyanic acid	C	B	A	A	A
hydro-drive, MIH-50 (petroleum base)	B	A	D	A	A
hydro-drive, MIH-10 (petroleum base)	B	A	D	A	A
hydrofluoric acid, 65% max.cold	D	E	A	A	A
hydrofluoric acid, 65% min.cold	D	D	C	A	A
hydrofluoric acid 65% max.hot	D	D	D	C	A
hydrofluoric acid, 65% min.hot	D	D	D	C	A
hydrofluosilicic acid	D	D	A	A	A
hydrogen gas, cold	C	C	A	A	A
hydrogen gas, hot	C	C	A	A	A
hydrogen peroxide (1)	A	A	A	A	A
hydrogen 90% (1)	B	B	C	B	A
hydrogen sulfide dry, cold	C	C	A	D	A
hydrogen sulfide dry, hot	C	C	A	D	A
hydrogen sulfide wet, coldC	C	A	D	A	A
hydrogen sulfide wet, hot	C	C	A	D	A

Resistance to different products:

A - excellent
B - good
C - insufficient
D - unsatisfactory
E - please, consult

	S I L I C O N E	F L U O O I L	B U T Y L F L O O D	V I T O S I L	P T F S I L
hydrolube-water/ethylene glycol	B	B	A	A	A
hydroquinone	E	B	D	D	A
hydyne	D	D	A	D	A
hyjet	E	E	A	D	A
hyjet III	E	E	A	D	A
hyjet S	E	E	A	D	A
hyjet W	E	E	A	D	A
hydrochlorous	E	E	B	A	A
I					
industron FF44	D	A	D	A	A
industron FF48	D	A	D	A	A
industron FF53	D	A	D	A	A
industron FF80	D	A	D	A	A
iodine	E	A	B	A	A
iodine pentafluoride	D	D	D	D	A
iodoform	E	E	A	E	A
isobutyl alcohol	A	B	A	A	A
iso-butyl N-butyrate	E	A	A	A	A
isododecane	E	A	D	A	A
iso-octane	D	A	D	A	A
isophorone (ketone)	D	D	A	D	A
isopropanol	A	B	A	A	A
isopropyl acetate	D	D	B	D	A
isopropyl alcohol	A	B	A	A	A
isopropyl chloride	D	B	D	A	A
isopropyl ether	D	C	D	D	A
J					
JP 3 (MIL-J-5624)	D	A	D	A	A
JP 4 (MIL-J-5624)	D	B	D	A	A
JP 5 (MIL-J-5624)	D	B	D	A	A
JP 6 (MIL-J-25656)	D	B	D	A	A
JP X (MIL-J-25604)	D	D	D	D	A
K					
kel F liquid	A	B	A	B	A
kerosene	D	A	D	A	A
keystone #87HX-grease	D	A	D	A	A
L					
lactams-amino acids	E	D	B	D	A
lactic acid, cold	E	A	A	A	A
lactic acid, hot	E	B	D	A	A
lacquers	D	D	D	D	A
lacquer solvents	D	D	D	D	A
lactic acid	A	A	A	A	A
lard, animals fats	B	A	D	A	A
lavender oil	D	B	D	A	A
lead acetate	D	D	A	D	A
lead nitrate	B	A	A	E	A
lead sulphamate	B	A	A	A	A
lehiff x 1169	D	A	D	A	A
lehigh x 1170	D	A	D	A	A
light greas	D	A	D	A	A
ligroin (petroleum ether or benzine)	D	A	D	A	A
lime bleach	B	A	A	A	A

lime sulphur	A	A	A	A	A
lindol, hydraulic fluid (phosphate ester type)	C	C	A	B	A
linoleic acid	B	E	D	B	A
linseed oil	A	A	C	A	A
liquid oxygen	D	D	D	D	A
liquid petroleum gas (LPG)	C	C	D	A	A
liquimoly	D	A	D	A	A
lubricating oils, di-ester	D	B	D	A	A
lubricating oils, petroleum base	D	A	D	A	A
lye solutions	B	B	A	B	A

M

magnesium chloride	A	A	A	A	A
magnesium hydroxyde	E	E	A	A	A
magnesium sulphate	A	A	A	A	A
magnesium sulphite	A	A	A	A	A
magnesium salt	A	A	A	A	A
malathion	D	B	D	A	A
maleic acid	E	E	D	A	A
maleic anhydride	E	E	D	A	A
malicacid	B	A	D	A	A
MCS 312	A	A	D	A	A
MCS 352	C	C	A	D	A
MCS 463	C	C	A	D	A
mercuric chloride	E	E	A	A	A
mercury	E	E	A	A	A
mercury vapor	E	E	A	A	A
mesityl oxide (ketone)	D	D	B	D	A
methane	D	B	D	A	A
methanol	A	A	A	A	A
methyl acetate	D	D	B	D	A
methyl acetoacetate	B	D	B	D	A
methyl acrylate	D	D	B	D	A
methylacrylic acid	D	D	B	C	A
methyl alcohol	A	A	A	D	A
methyl benzoate	D	A	B	A	A
methyl bromide	E	A	D	A	A
methyl butyl ketone	D	D	A	D	A
methyl carbonate	D	B	D	A	A
methyl cellosolve	D	D	B	D	A
methyl cellulose	B	D	B	D	A
methyl chloride	D	B	C	A	A
methyl chloroformate	D	B	D	A	A
methyl D-bromide	D	B	E	A	A
methyl cyclopentane	D	B	D	A	A
methylene chloride	D	B	D	B	A
methylene dichloride	D	B	D	B	A
methyl ether	A	A	A	A	A
methyl ethyl ketone (MEK)	D	D	A	D	A
methyl ethyl ketone peroxyde	B	D	D	D	A
methyl format	B	E	B	E	A
methyl isobutyl ketone (MIBK)	D	D	C	D	A
methyl isopropyl ketone	D	D	B	D	A
methyl methacrylic	C	D	D	D	A
methyl oleate	E	B	B	A	A
methyl salicylate	E	E	B	E	A
milk	A	A	A	A	A
mineral oils	B	A	D	A	A
mobil 24 DTE	D	A	D	A	A
mobil HF	E	A	D	A	A
mobil delvac 1100, 1110, 1130	D	A	D	A	A
mobil nyvac 20 and 30	A	A	A	A	A
mobil velocite C	D	A	D	A	A
mobilgas wa 200, type A	D	A	D	A	A
automatic trans. fluid					
mobil oil SAE20	D	A	D	A	A

mobiltherm 600	D	A	D	A	A
mobilux	D	A	D	A	A
mono bromobenzene	D	B	D	A	A
mono chlorobenzene	D	B	D	A	A
mono ethanolamine	B	D	B	D	A
monomerthyl aniline	E	E	E	B	A
monomerthylether	E	E	A	E	A
monomerthyl hydrazine	D	E	A	E	A
monotrotoluene & dinitrotoluene(40-60mix)	D	C	D	C	A
monovinyl acethylene	B	E	A	A	A
mopar brake fluid	C	D	A	D	A
mustard gas	A	E	A	E	A

N

naptha	D	B	D	A	A
naphthalene	D	A	D	A	A
napthenic	D	A	D	A	A
natural gas	A	C	D	A	A
neatsfoot oil	B	A	B	A	A
neon	A	A	A	A	A
neville acid	D	B	B	A	A
nickel acetate	D	D	A	D	A
nickel chloride	A	A	A	A	A
nickel salts	A	A	A	A	A
nickel sulfate	A	A	A	A	A
niter cake	A	A	A	A	A
nitric acid (I) 3 molar	D	C	B	A	A
nitric acid (I) concentrated	D	D	D	A	A
nitric acid dilute	B	B	B	A	A
nitric acid (I) red fuming (RFNA)	D	D	D	C	A
nitric acid (I) inhibited red fuming (IRFNA)	D	D	D	B	A
nitrobenzene	D	D	D	B	A
nitrobenzine	E	A	C	A	A
nitroethane	D	D	B	D	A
nitrogene	A	A	A	A	A
nitrogene (textroixide) (N204) (I)	D	D	D	D	A
nitromethane	D	D	B	D	A
nitropropane	D	D	B	D	A

O

o-a-548 A	B	B	A	B	A
o-t-634b	D	B	D	A	A
octachlorotoluene	D	B	D	A	A
octadecane	D	A	D	A	A
N-octane	D	B	D	A	A
octyl alcohol	D	B	A	A	A
oleic acid	E	E	B	B	A
oleum (fuming sulfuric acid)	D	E	D	A	A
oleum spirits	D	B	D	A	A
olive oil	D	A	B	A	A
oronite 8200	D	A	D	A	A
oronite 8515	D	A	D	A	A
orthochloroethylbenzene	D	B	D	A	A
ortho-dichlorobenzene	D	B	D	A	A
os45 type III (os45)	D	B	D	A	A
os45 type IV (os45)	D	B	D	A	A
OS70	D	B	D	A	A
oxalic acid	B	A	A	A	A
oxygen, cold	A	A	A	A	A
oxygen, cold 200-400°F	B	D	D	B	A
ozone	A	B	A	A	A

P

p-s-66 lb	D	A	D	A	A
p-d-680	D	A	D	A	A
paint thinner duco	D	B	D	B	A

SILICONE HOSES

FOR INDUSTRIAL VEHICLES



Please call Goodyear Rubber Products to order any products shown in this catalog

1-727-822-4672 or 1-800-367-4673 toll free in the USA

Email inquiries to: Sales@GoodyearRubberProducts.com

VENA SIL 200 / VENA SIL 240

SILICONE HOSE WITH POLYESTER REINFORCEMENT FOR HEATING AND COOLING EQUIPMENT



GENERAL CHARACTERISTICS:

The VENA SIL 200/240 product line is made with Vinyl Methyl Quality (VMQ) silicone with a plain outer and inner appearance. Temperature range is -76°F to +356°F.

SIL 200: 3 ply polyester reinforcement (standard for ID < 2.0") with wall thickness of 4.2mm.
 SIL 240: 4 ply polyester reinforcement (standard for ID > 2.0") with wall thickness of 5.2mm.

Other types of textile reinforcement, such as NOMEX (1) and fiberglass, are available upon request.

STRAIGHT HOSE

Standard Length: From 1 to 4 m (3' to 13'). Can be cut to smaller lengths upon request.
 Applications: Suitable for use in straight lengths, with no bending requirements.
 Other dimensions are available by special order.

(1) NOMEX is a registered trademark of Dupont.

Inner Diameter		Working Pressure				Bursting Pressure			
inches	mm	psi Sil200	psi Sil240	bar Sil200	bar Sil240	psi Sil200	psi Sil240	bar Sil200	bar Sil240
1/4"	6	214	307	14.8	21.2	642	920	44.3	63.4
5/16"	8	172	249	11.9	17.2	517	749	35.6	51.6
3/8"	10	146	213	10.1	14.7	438	638	30.2	44.0
1/2"	13	120	177	8.3	12.2	360	529	24.8	36.5
5/8"	16	103	152	7.1	10.5	307	455	21.2	31.4
3/4"	19	90	134	6.2	9.2	270	403	18.6	27.8
7/8"	22	80	120	5.5	8.3	240	362	16.5	25.0
1"	25	72	110	5.0	7.6	217	330	15.0	22.8
1 1/8"	28	67	101	4.6	7.0	200	304	13.8	21.0
1 3/16"	30	62	97	4.3	6.7	188	290	13.0	20.0
1 1/4"	32	59	92	4.1	6.3	180	277	12.4	19.1
1 3/8"	35	55	87	3.8	6.0	176	259	12.1	17.9
1 1/2"	38	52	81	3.6	5.6	156	245	10.8	16.9
1 9/16"	40	50	78	3.4	5.4	150	236	10.3	16.3
1 3/4"	45	45	72	3.1	5.0	136	217	9.4	15.0
1 7/8"	48	43	70	3.0	4.8	130	207	9.0	14.3
2"	51	40	66	2.8	4.6	123	198	8.5	13.7
2 1/8"	55	39	62	2.7	4.3	116	187	8.0	12.9
2 1/4"	57	37	61	2.6	4.2	113	182	7.8	12.5
2 3/8"	60	36	59	2.5	4.1	109	177	7.5	12.2
2 1/2"	63	34	56	2.3	3.9	104	169	7.2	11.7
2 5/8"	67	33	55	2.3	3.8	101	166	7.0	11.4
2 3/4"	70	32	52	2.2	3.6	95	158	6.5	10.9
3"	76	29	49	2.0	3.4	88	149	6.1	10.3
3 1/8"	80	29	47	2.0	3.2	85	143	5.9	9.9
3 1/2"	90	26	43	1.8	3.0	76	132	5.2	9.1
4"	102	23	40	1.6	2.8	69	121	4.8	8.3
4 1/8"	105		37		2.6		115		7.9
4 1/3"	110		34		2.3		105		7.3
4 1/2"	114		32		2.2		99		6.8
4 3/4"	121		29		2.0		90		6.2
5"	127		27		1.9		84		5.8
6"	152		24		1.7		74		5.1
8"	204		21		1.4		65		4.5

Inner Diameter		Length		Inner Diameter		Length	
inches	mm	inches	mm	inches	mm	inches	mm
5/8" > 1/2"	16 > 13	4"	102	1 5/8" > 1 3/8"	42 > 35	4"	102
3/4" > 1/2"	19 > 13	4"	102	1 3/4" > 1 1/4"	45 > 32	4"	102
3/4" > 5/8"	19 > 16	4"	102	1 3/4" > 1 3/8"	45 > 35	4"	102
7/8" > 5/8"	22 > 16	4"	102	1 3/4" > 1 1/2"	45 > 38	4"	102
1" > 3/4"	25 > 19	4"	102	2" > 1 1/2"	51 > 38	4"	102
7/8" > 3/4"	22 > 19	4"	102	2" > 1 3/4"	51 > 45	4"	102
1 1/8" > 3/4"	28 > 19	4"	102	2 1/8" > 2"	55 > 51	4"	102
1 1/8" > 7/8"	28 > 22	4"	102	2 1/4" > 2"	57 > 51	4"	102
1 1/8" > 1"	28 > 25	4"	102	2 3/8" > 2"	60 > 51	5"	127
1 1/4" > 1"	32 > 25	4"	102	2 1/2" > 2"	63 > 51	5"	127
1 3/8" > 1"	35 > 25	4"	102	2 3/4" > 2"	70 > 51	5"	127
1 3/8" > 1 1/8"	35 > 28	4"	102	2 3/4" > 2 1/4"	70 > 57	5"	127
1 3/8" > 1 1/4"	35 > 32	4"	102	2 3/4" > 2 3/8"	70 > 60	5"	127
1 1/2" > 1 7/8"	38 > 48	4"	102	3" > 2"	76 > 51	5"	127
1 1/2" > 1"	38 > 25	4"	102	3" > 2 1/2"	76 > 63	5"	127
1 1/2" > 1 1/8"	38 > 28	4"	102	3 1/8" > 2 3/4"	80 > 70	5"	127
1 1/2" > 1 1/4"	38 > 32	4"	102	3 1/2" > 3 1/8"	90 > 80	6"	152
1 1/2" > 1 3/8"	38 > 35	4"	102	4" > 3"	102 > 76	6"	152

STRAIGHT REDUCER



Inner Diameter		Arm Length		Inner Diameter		Arm Length	
inches	mm	inches	mm	inches	mm	inches	mm
1/4"	6	4"	102	2"	51	8"	152
5/16"	8	4"	102	2 1/8"	55	8"	152
3/8"	10	4"	102	2 1/4"	57	8"	152
1/2"	13	4"	102	2 3/8"	60	8"	152
5/8"	16	4"	102	2 1/2"	63	8"	152
3/4"	19	6"	127	2 5/8"	67	4"	102
7/8"	22	8"	152	2 3/4"	70	4"	102
1"	25	8"	152	3"	76	4"	102
1 1/8"	28	8"	152	3 1/8"	80	4"	102
1 3/16"	30	8"	152	3 1/2"	90	4"	102
1 1/4"	32	8"	152	3 3/4"	95	6"	127
1 3/8"	35	4"	102	4"	102	8"	152
1 1/2"	38	4"	102	4 1/8"	105	8"	152
1 9/16"	40	4"	102	4 1/2"	110	8"	152
1 5/8"	41	4"	102	4 3/4"	114	8"	152
1 3/4"	45	4"	102	5"	127	8"	152
1 7/8"	48	6"	127				



45°

ELBOW 45°/ 90°/ 135°



90°



135°

REDUCER ELBOW 90°

Inner Diameter		Arm Length	
inches	mm	inches	mm
1" > 3/4"	25 > 19	4"	102
1 1/4" > 1"	32 > 25	4"	102
1 1/2" > 1"	38 > 25	4"	102
1 1/2" > 1 1/4"	38 > 25	6"	152
1 1/2" > 1 3/8"	38 > 35	6"	152
2" > 1 3/4"	51 > 45	6"	152
2 3/8" > 2"	60 > 51	4"	102
2 1/2" > 2"	63 > 51	4"	102
2 3/4" > 2"	70 > 51	4"	102
2 3/4" > 2 3/8"	70 > 60	6"	152
3" > 2"	76 > 51	6"	152
3" > 2 1/2"	76 > 63	6"	152



VENA SIL 700

HIGHLY FLEXIBLE SILICONE HOSE WITH POLYESTER REINFORCEMENT FOR HEATING AND COOLING EQUIPMENT

Material: Silicone VMQ (Vinyl Methyl Quality).
Structure: Spiral steel wire between 3 sheets of polyester fabric covered in blue silicone.
Temperature range: - 76°F to + 356°F
Standard wall thickness: 4.6mm.
Length: From 1 to 4 m. Can be cut to smaller lengths upon request.
Main advantage: High flexibility due to the wire spiral.
Appearance: Plain outer and inner appearance. Suitable for use where a small bending radius is required.



Inner Diameter*		Working Pressure		Bursting Pressure		Bending Radius	
inches	mm	psi	bar	psi	bar	inches	mm
1/2"	13	164	11.48	491	34.37	3"	76
5/8"	16	151	10.57	452	31.64	3 1/4"	82
3/4"	19	139	9.73	419	29.33	3 1/2"	90
7/8"	22	130	9.1	391	27.37	3 3/4"	95
1"	25	122	8.54	367	25.69	4 1/4"	108
1 1/8"	28	114	7.98	345	24.15	4 1/2"	115
1 3/16"	30	110	7.7	332	23.24	4 3/4"	120
1 1/4"	32	103	7.21	309	21.63	5 1/2"	140
1 3/8"	35	101	7.07	303	21.21	5 3/4"	146
1 1/2"	38	95	6.65	287	20.09	6 1/4"	158
1 9/16"	40	93	6.51	277	19.39	6 1/2"	165
1 5/8"	42	87	6.09	259	18.13	7 1/4"	184
1 3/4"	45	85	5.95	255	17.85	7 1/2"	190
1 7/8"	48	81	5.67	242	16.94	8 1/4"	210
2"	51	78	5.46	235	16.45	8 3/4"	222

* Maximum diameter is 4.3"

VENA SIL 800

HIGHLY FLEXIBLE SILICONE HOSE WITH POLYESTER REINFORCEMENT FOR HEATING AND COOLING EQUIPMENT

Material: Silicone VMQ (Vinyl Methyl Quality).
Structure: Spiral steel wire between 3 sheets of polyester fabric covered in blue silicone.
Temperature range: - 76°F to + 356°F
Standard wall thickness: 4.6mm.
Length: From 1 to 4 m. Can be cut to smaller lengths upon request.
Main advantage: High flexibility due to spiral wiring.
Appearance: Corrugated outer and inner appearance. Suitable for use where a very small bending radius is required.



Inner Diameter*		Working Pressure		Bursting Pressure		Bending Radius	
inches	mm	psi	bar	psi	bar	inches	mm
1"	25	100	7	300	21	2 1/4"	57
1 1/8"	28	93	6.51	280	19.6	2"	51
1 3/16"	30	90	6.3	268	18.76	2 3/4"	70
1 1/4"	32	85	5.95	258	18.06	2 3/4"	70
1 3/8"	35	81	5.67	242	16.94	3"	76
1 1/2"	38	75	5.25	227	15.89	3 1/4"	82
1 9/16"	40	72	5.04	219	15.33	3 1/2"	90
1 5/8"	42	71	4.97	211	14.77	3 3/4"	95
1 3/4"	45	68	4.76	203	14.21	4"	102
2"	51	59	4.13	178	12.46	4 3/4"	120
2 1/8"	55	55	3.85	165	11.55	5 1/4"	133
2 1/4"	57	53	3.71	159	11.13	5 3/4"	146
2 3/8"	60	50	3.5	1151	80.57	6 1/4"	158
2 1/2"	63	48	3.36	1142	79.94	6 3/4"	171

* Maximum diameter is 4.3"

VENA SIL 200/240 R/A

*OIL-RESISTANT SILICONE HOSE
WITH POLYESTER REINFORCEMENTS*

External material: Silicone VMQ (Vinyl Methyl Quality).

Internal material: Silicone R/A (Oil-Resistant).

Textile reinforcement: 3-ply polyester (Sil 200) / 4ply polyester (Sil 240)

Temperature range: - 76°F to + 356°F

Standard wall thickness: 4.2mm.

Length: From 1 to 4 m.

Can be cut to smaller lengths upon request.

Appearance: Plain outer and inner appearance.

Application: Suitable for engine oils and other mineral oils up to + 302° F service temperature. Suitable for use in straight lengths with no bending requirements.



Inner Diameter		Working Pressure		Bursting Pressure		Inner Diameter		Working Pressure		Bursting Pressure	
inches	mm	psi	bar	psi	bar	inches	mm	psi	bar	psi	bar
1/4"	6	214	14.98	642	44.94	1 3/4"	45	45	3.15	136	9.52
5/16"	8	172	12.04	517	36.19	1 7/8"	48	43	3.01	130	9.1
3/8"	10	146	10.22	438	30.66	2"	51	40	2.8	123	8.61
1/2"	13	120	8.4	360	25.2	2 1/8"	55	39	2.73	116	8.12
5/8"	16	103	7.21	307	21.49	2 1/4"	57	37	2.59	113	7.91
3/4"	19	90	6.3	270	18.9	2 3/8"	60	36	2.52	109	7.63
7/8"	22	80	5.6	240	16.8	2 1/2"	63	34	2.38	104	7.28
1"	25	72	5.04	217	15.19	2 5/8"	67	33	2.31	101	7.07
1 1/8"	28	67	4.69	200	14	2 3/4"	70	32	2.24	95	6.65
1 3/16"	30	62	4.34	188	13.16	3"	76	29	2.03	88	6.16
1 1/4"	32	59	4.13	180	12.6	3 1/8"	80	29	2.03	85	5.95
1 3/8"	35	55	3.85	176	12.32	3 1/2"	90	26	1.82	76	5.32
1 1/2"	38	52	3.64	156	10.92	4"	102	23	1.61	69	4.83
1 9/16"	40	50	3.5	150	10.5						

VENA SIL GLASS

*STRAIGHT SILICONE HOSE REINFORCED WITH
FIBERGLASS FOR HIGH TEMPERATURES*

Material: High temperature resistant silicone.

Textile reinforcement: 3 ply of fiberglass

Temperature range: -76° to + 455°F
(up to + 482°F for short periods of time).

Standard wall thickness: 2.8mm.

Length: From 1 to 4 m.

Can be cut to smaller lengths upon request.

Appearance: Plain outer and inner appearance.

Suitable for use in straight lengths, with no bending requirements.

Special shapes available upon request (e.g. elbow, reducer, etc.).



VENA SIL TURBO

SILICONE HOSE FOR TURBOCHARGER SYSTEMS

- External material:** Silicone VMQ (Vinyl Methyl Quality).
- Internal material:** Silicone FVMQ (Fluor Vinyl Methyl Quality).
- Textile reinforcement:** 3 plies of NOMEX
- Temperature range:** - 76° to + 392°F
(up to 428°F for short periods of time).
- Standard wall thickness:** 3.7mm.
- Length:** From 1 to 4 m. Can be cut to smaller lengths upon request.
- Appearance:** Plain outer and inner appearance.
- Application:** Mainly used in the turbocharger system for industrial vehicles, due to its high capacity to withstand hydrocarbons and/or oil particles in the cooled, pressurized air. Can also be used in other areas where hydrocarbons and/or oil particles are present. Suitable for use in straight lengths, with no bending requirements.

Special shapes available upon request (e.g. elbow, reducer, etc.).

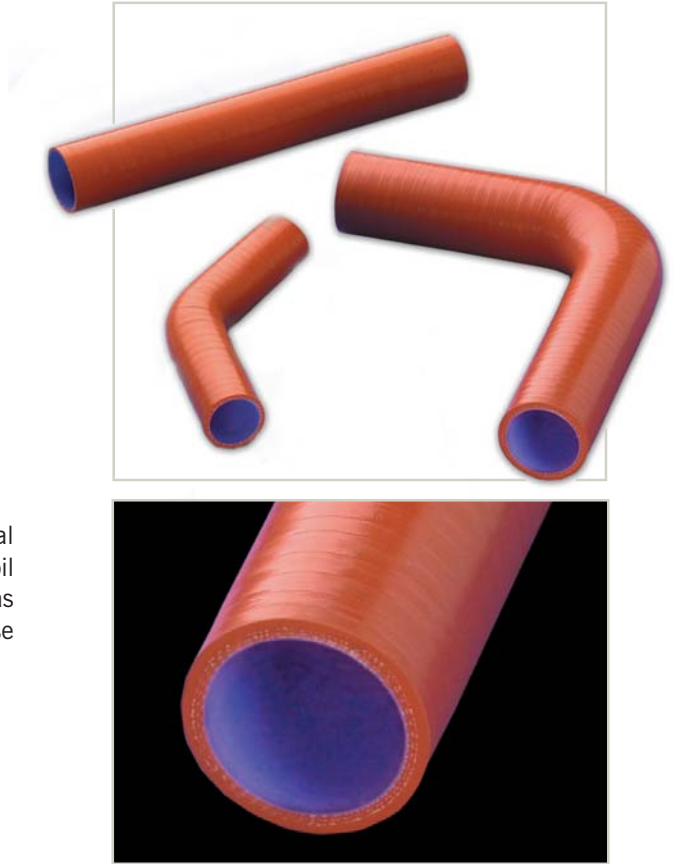

CUSTOM SHAPES and HOSES

NON-STANDARD SILICONE HOSES

We also design and manufacturer custom shaped hoses to meet your specific needs.



CERTIFICATION



UNE EN ISO 9001:2000



UNE EN ISO 14001:1996



EMAS

TURBOLOADER

CORRUGATED SILICONE HOSE FOR TURBOCHARGER SYSTEMS

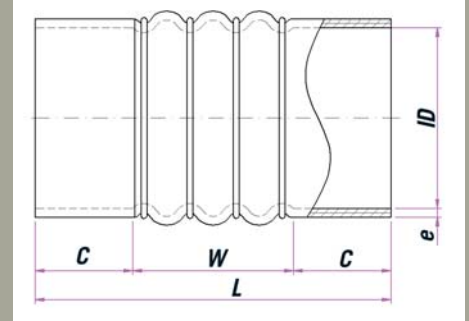

External material:

Silicone VMQ (Vinyl Methyl Quality).

Internal material:

Silicone FVMQ (Fluor Vinyl Methyl Quality).

Textile reinforcement:

NOMEX
Temperature range: - 76° to + 392°F
(up to 428°F for short periods of time).

Standard Wall thickness: 3.7mm.

Standard length: (See table below).

Appearance: Corrugated outer and inner appearance.

Application: Specifically used in turbocharger systems for industrial vehicles, due to its

high capacity to withstand hydrocarbons and/or oil particles in cooled, pressurized air.

Options: Also available without the FVMQ (Fluor Vinyl Methyl Quality) silicone. The standard VMQ (Vinyl Methyl Quality) silicone is used instead.

Inner Diameter		Number of Humps	Number of Rings	Total Length of Humps (W)		Cuff length (C)		Total Length	
inches	mm			inches	mm	inches	mm	inches	mm
2"	51	2	3	2 1/2"	63	1 7/8"	48	6 1/4"	158
2"	51	4	5	4 1/2"	115	1 5/8"	42	8"	204
2 3/8"	60	2	3	2 1/2"	63	1 7/8"	48	6 1/4"	158
2 3/8"	60	4	5	4 1/2"	115	1 5/8"	42	8"	204
2 1/2"	63	3	4	3 1/2"	90	2 1/4"	57	8"	204
2 3/4"	70	2	3	2 1/2"	63	1 7/8"	48	6 1/4"	158
2 3/4"	70	4	5	4 1/2"	115	1 5/8"	42	8"	204
3"	76	2	3	2 1/2"	63	1 7/8"	48	6 1/4"	158
3"	76	4	5	4 1/2"	115	1 5/8"	42	8"	204
3 1/8"	80	3	4	3 1/2"	90	2 1/4"	57	8"	204
3 1/8"	80	6	7	6 3/4"	171	2 3/4"	70	12"	306
3 1/4"	82	3	4	3 1/2"	90	2 1/4"	57	8"	204
3 1/4"	82	6	7	6 3/4"	171	2 3/4"	70	12"	306
3 1/2"	90	1	2	1 1/2"	38	1 1/4"	32	4"	102
3 1/2"	90	2	3	2 1/2"	63	1 7/8"	48	6 1/4"	158
3 1/2"	90	4	5	4 1/2"	115	1 7/8"	48	8 1/4"	210
3 1/2"	90	5	6	5 1/2"	140	2 1/4"	57	10"	255
3 1/2"	90	6	7	6 3/4"	171	2 3/4"	70	12"	306
3 3/4"	95	4	5	5"	127	1 9/16"	40	8 1/4"	210
3 3/4"	95	6	7	6 3/4"	171	2 3/4"	70	12"	306
4"	102	1	2	1 1/2"	38	1 1/4"	32	4"	102
4"	102	2	3	2 1/2"	63	1 7/8"	48	6 1/4"	158
4"	102	4	5	4 1/2"	115	1 7/8"	48	8 1/4"	210
4"	102	5	6	5 1/2"	140	2 1/4"	57	10"	255
4"	102	6	7	6 3/4"	171	2 3/4"	70	12"	306
4 1/2"	115	3	4	3 1/2"	90	2 1/4"	57	8"	204

Available TURBOLOADERS (consult for other dimensions)

SELF-TENSIONING STEPLESS SCREW CLAMPS

VENAIR's Self-Tensioning Stepless Screw Clamps

are size adjustable and were specifically developed for use with silicone hoses in motor vehicle cooling systems.

The narrow width of these clamps in comparison with alternative clamps of similar design, coupled with the low installation torque, combine to ensure a precisely defined clamping pressure on the hose.

Material:

These Self-Tensioning Stepless Screw Clamps are made from austenitic stainless steel. The primary material employed is a nickel alloy designated DIN 1.4301 / UNS S30400, and contains ca. 18% chromium and ca. 8% nickel. This alloy acquires additional strength through cold working in the course of strip and clamp manufacture.

Features:

- Compression spring reacts to diameter changes caused by thermal expansion and contraction, ensuring continual all-season sealing and a permanent system against leakage.
- 360° stepless design- no steps or overlaps around the internal circumference.
- Specially formed strip edges prevent damage to adjacent hose.
- Reusable.
- Narrow band width provides localized clamping force.
- Conforms to: SAE J1508 Type SSPC, TMC RP332 Type SSPC.

Design:

- Material is 9 mm wide and 0.6 mm thick, ensuring optimum sealing capabilities with silicone hoses, while taking into account the necessary radial force, the compressibility of the hose, the sealing/ retaining properties, and the environmental conditions.

These Self-Tensioning Stepless Screw Clamps are available for our entire range of industrial silicone hoses, from inner diameters as small as 1/4" to as large as 8".



Please call Goodyear Rubber Products to order any products shown in this catalog

1-727-822-4672 or 1-800-367-4673 toll free in the USA

Email inquiries to: Sales@GoodyearRubberProducts.com

SILICONE HOSES FOR THE MARINE INDUSTRY

MARINE WET EXHAUST SILICONE HOSES VENA SIL 500 (ACCORDING TO SAE J2006)

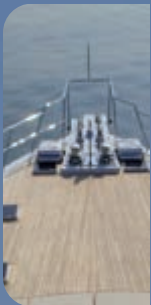
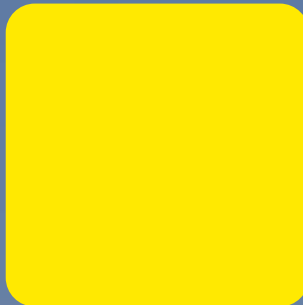
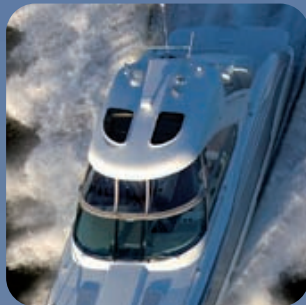
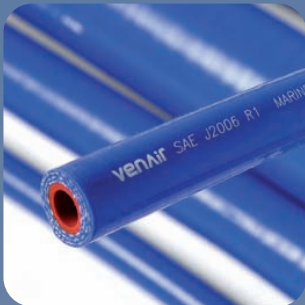

SILICONE HOSES FOR THE MARINE INDUSTRY

MARINE WET EXHAUST SILICONE HOSES

VENA SIL 500

(ACCORDING TO ISO 13363 AND SAE J2006)

Venair, specialists in the production and design of flexible silicone hoses and special parts since 1986, offers the VENA SIL 500 range of silicone hoses, certified ISO 13363 and SAE J2006, for all kinds of marine engines:

CORRUGATED STRAIGHT JOINT VENA SIL 500

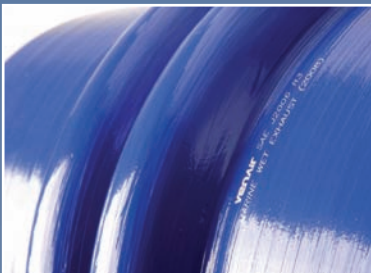

- All **VENA SIL 500** hoses are made from silicone and have several layers of polyester fibre to withstand the pressures to which they are subjected in this industry.
- Range of diameters: from 6mm (1/4") to 508mm (20")
- Range of temperatures: from -40°C to +180°C / -40° to +356° F
- Wall thickness: according to diameter
- Pressure resistance: according to ISO 13363 and SAE J2006

STRAIGHT HOSE VENA SIL 500



90°, 45° OR 135° ELBOW VENA SIL 500



OTHER SILICONE HOSES

In addition to this range, Venair offers a large variety of hoses to meet any of its customers' needs:

- Highly flexible straight hose, including wire spiral between the silicone layers.
- Silicone hose with fabrics that can resist very high temperatures (Nomex or fibreglass).
- Silicone hose resistant to oils and hydrocarbon particles (SIL RA, Fluorosilicone).
- Compensators and special shapes, designed to customer specifications.



DIN EN ISO 9001:2000
Certificado Nº 01 100 78058



UNE EN ISO 14001
Certificado Nº 01 100 78058