

Please call Goodyear Rubber Products to order any products shown in this catalog

1-727-822-4672 or 1-800-367-4673 toll free in the USA

Email inquiries to: [Sales@GoodyearRubberProducts.com](mailto:Sales@GoodyearRubberProducts.com)

**Catalog GC-04**

# Van Gorp®

## UNIT AND BULK Conveyor Pulleys



**ISO 9001 Certified**

VAN GORP provides immediate service from any of our conveniently located warehouses. This coast-to-coast network of *Pulley Places<sup>SM</sup>* means you get the pulley you need when you need it.

VAN GORP's factory warehouse serves the entire midwest region from its centrally located facilities in Pella, Iowa.

Other warehouses are strategically located across the United States and Canada. Please contact VAN GORP for the warehouse nearest you.

**SAFETY DEVICES** — The products are provided with only those safety devices identified herein. It is the responsibility of the purchaser to furnish appropriate guards for machinery parts in compliance with OSHA standards, as well as any other safety devices desired by purchaser and/or required by law.

**VAN GORP PRODUCTS** pictured, described, or listed in this publication are illustrative only. Application and use of these products must be in accordance with applicable codes and regulations and must be arranged and/or provided with covers or other guards where necessary to assure the safety of personnel.

**VAN GORP concentrates entirely on pulleys — all day, every day. That's why service from *The Pulley Place*® is the most dependable you can find!**

## GENERAL INDEX

<b>Bushings</b>	
XT® .....	6-7
Tapered Bore .....	8
Q-D® .....	9
<b>Conveyor Pulley Assemblies</b> .....	31
<b>Lagging (Bulk and Unit)</b> .....	17
<b>Unit Handling Drums</b>	
Finished Bore Drum .....	18
Stock Machined Crown Finished Bore .....	18
True Turn® Drum .....	19
<b>Unit Handling Rollers</b> .....	20
<b>Bulk Handling Drums</b>	
H•D•R® Drum .....	10
XT-reme™ .....	11
Mine Duty .....	12
Turbine Disc .....	13
Double Drum™ .....	14-15
Elevator .....	16
Spiral Drum .....	25
<b>Wing</b>	
Turn-Clean™ Wing .....	22
XT-reme™ Wing .....	23
Extra Heavy Duty .....	24
Lt. Weight Slat .....	24
Spiral Wing .....	25
Snap-Back® .....	27
◆DB◆ Wing Lagging .....	26
<b>Special Attachments &amp; Modifications</b> .....	29
<b>Shafting</b> .....	30
<b>Dead Shaft Pulleys</b> .....	21



ROUGH TOP LAGGING - Page 17



TRUE TURN® - Page 19

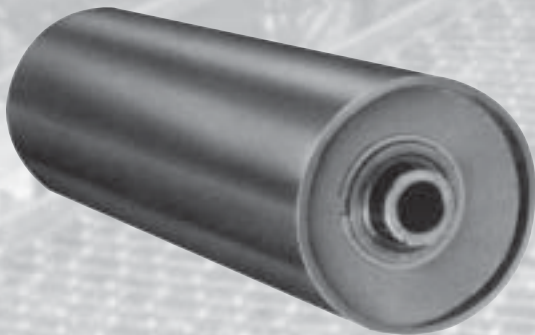

CONVEYOR ROLLERS - Page 20

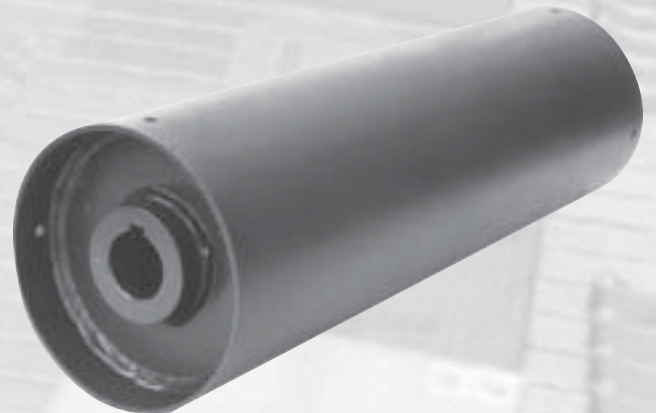

FINISHED BORE DRUM - Page 18

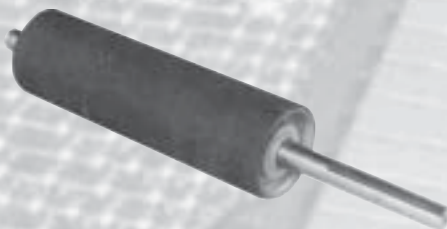

PACKAGE HANDLING PULLEYS - Page 19

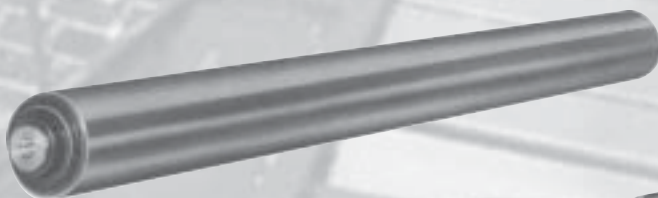

ROLLERS WITH ER BEARINGS - Page 20

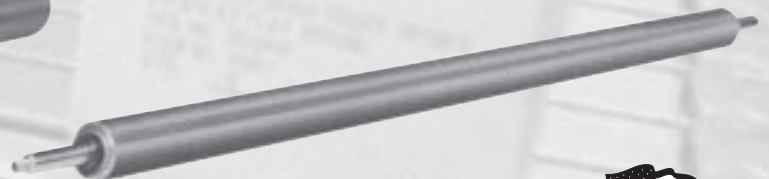

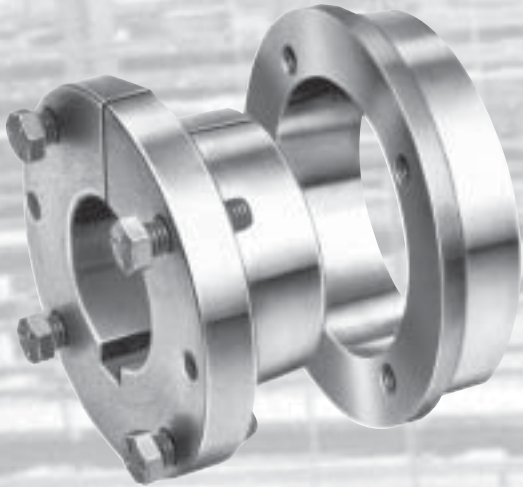

XT®

Van Gorp® Pulleys are available with XT®, Tapered Bore or Q-D® Hubs on all catalog size and special or engineered pulleys.

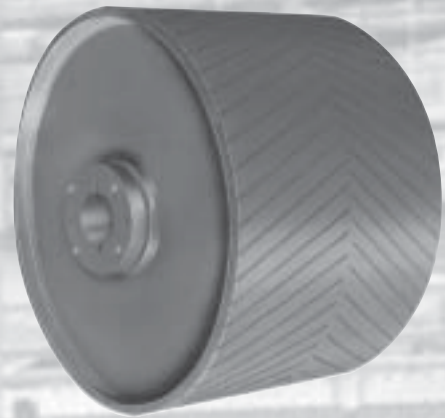

MINE DUTY - Page 12

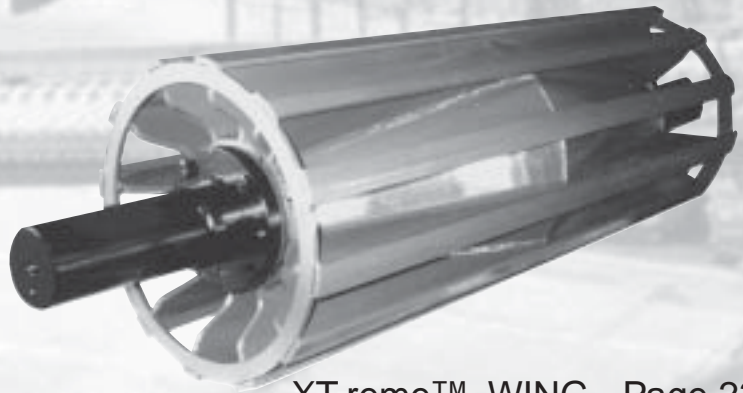

XT-reme™ WING - Page 23

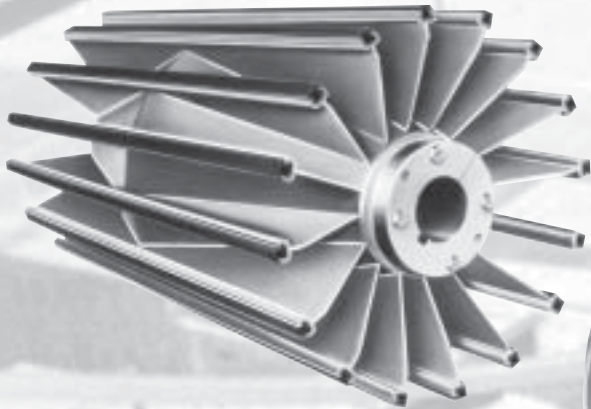

SNAP-BACK® - Page 27



SPIRAL DRUM - Page 25

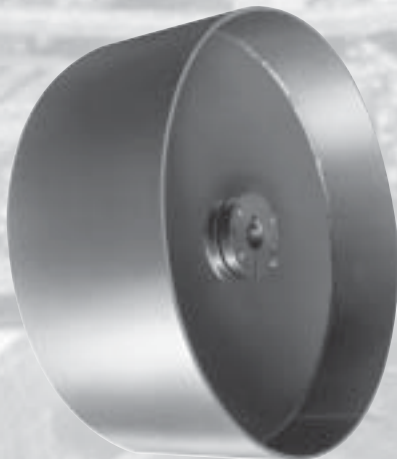

ELEVATOR - Page 16

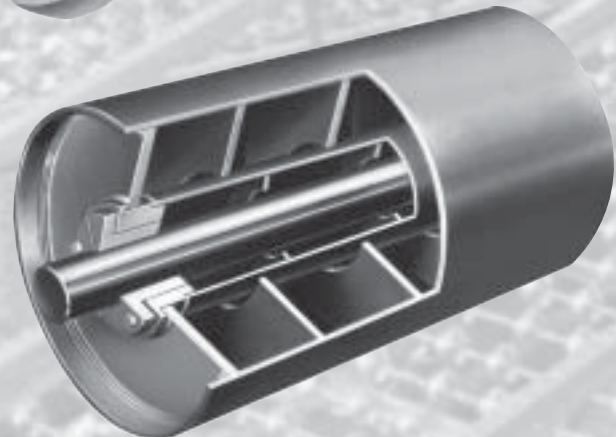

DOUBLE DRUM™ - Page 14

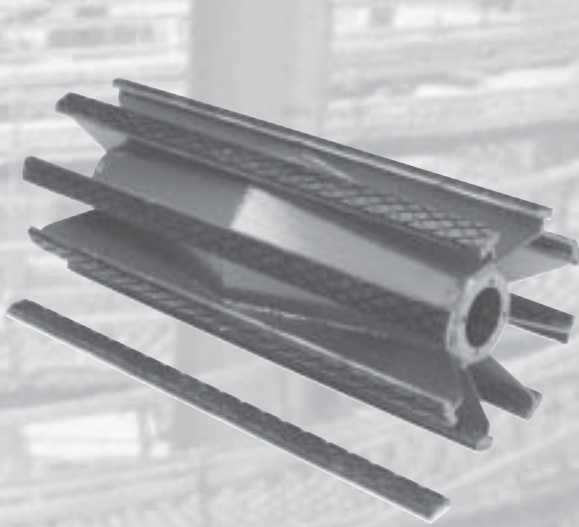

◆DB◆ WING LAGGING - Page 26



LIGHTWEIGHT  
SLAT WING- Page 24



H•D•R® - Page 10



TURBINE DISC - Page 13

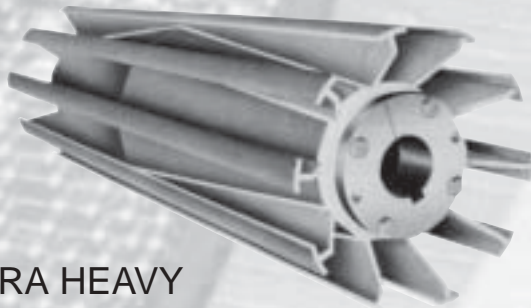

EXTRA HEAVY  
DUTY WING - Page 24



VULCANIZED AND  
SLIDE-LAG® - Page 17

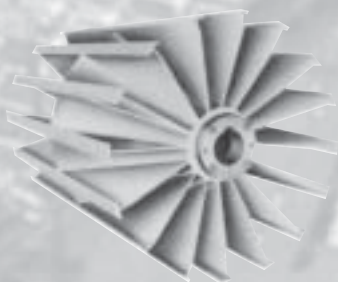

TURN CLEAN™ - Page 22

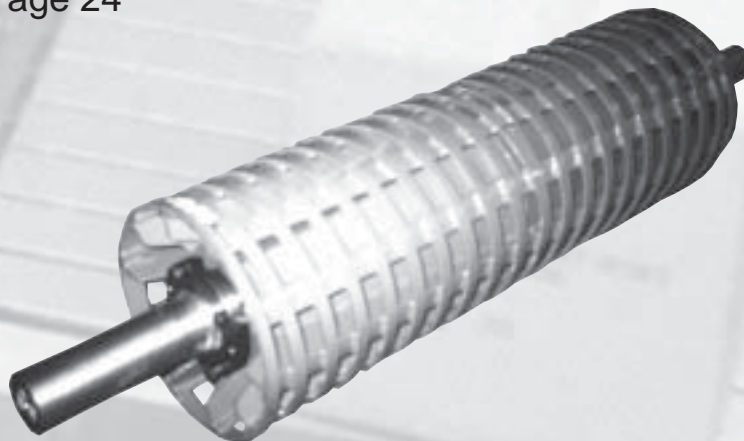

SPIRAL WING - Page 25





## A breakthrough in conveyor pulley design

XT® Hubs & Bushings are specifically developed for conveyor pulley applications. The XT® design utilizes a 2"/ft. taper, providing superior holding power for conveyor pulleys, while permitting easier installation and removal than other bushing types.

XT® hubs and bushings are available in all of the major types and sizes of Van Gorp conveyor pulleys. For further information, consult your VAN GORP distributor.

VAN GORP® conveyor pulleys offer you opportunities for increasing conveyor performance and reduce costs, because they utilize the XT® hub and bushing with all of these outstanding features:

- Designed specifically for conveyor pulley applications
- 2" per foot taper
- Malleable iron in many sizes
- Self-seating — eliminates need for hammer and drift
- Less axial movement — reduces end disc prestressing
- High compressive force minimizes pulley walking on shaft
- Bolts equally spaced for uniform draw-up
- More material in the barrel for added safety, especially in maximum bore sizes
- Full length engagement with hub
- Flange provides for maximum capscrew torque-storing capacity
- Easy removal
- Full size keys in maximum bores of size 50 and larger bushings

## XT® HUBS

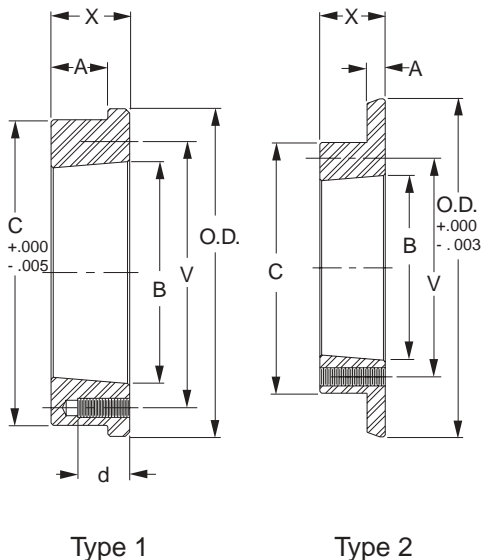
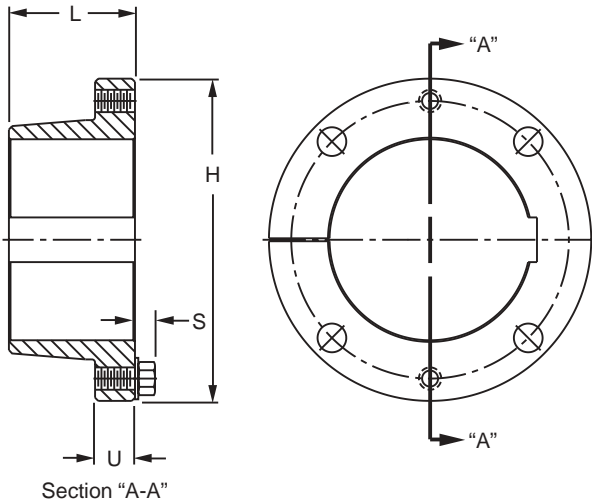

Table No. 1 — Specifications

Part No.	For Bushing	DIMENSIONS						TAPPED HOLES		Wt. Lbs.	
		O.D.	A	B	C	V	X	d	No.		Size
<b>Type 1 - Hubs</b>											
XTH15	XTB15	3.190	7/16	2.000	2.875	2 7/16	5/8	5/8	4	1/4 - 20NC	.7
XTH20	XTB20	4.065	9/16	2.688	3.8125	3 3/16	13/16	13/16	4	5/16 - 18NC	1.5
XTH25	XTB25	4.690	13/16	3.188	4.375	3 3/4	1 1/8	1 1/8	4	3/8 - 16NC	2.6
XTH30	XTB30	5.940	7/8	3.875	5.750	4 9/16	1 1/4	1 1/16	4	7/16 - 14NC	4.1
XTH35	XTB35	6.565	1 1/16	4.688	6.345	5 7/16	1 1/2	1 1/4	4	1/2 - 13NC	6.6
XTH40	XTB40	7.563	1 1/4	5.313	7.250	6 1/8	1 3/4	1 3/8	4	9/16 - 12NC	10.7
XTH45	XTB45	8.315	1 1/2	5.938	8.000	6 7/8	2 1/8	1 9/16	4	5/8 - 11NC	15.4
XTH50	XTB50	9.940	1 3/4	7.250	9.563	8 5/16	2 1/2	1 3/4	4	3/4 - 10NC	24.9
XTH60	XTB60	11.690	1 15/16	8.625	11.250	9 7/8	2 3/4	1 5/8	4	7/8 - 9NC	36.4
XTH70	XTB70	13.628	2 3/16	10.000	13.188	11 9/16	3 1/8	1 15/16	4	1 - 8NC	57.7
XTH80	XTB80	14.940	2 7/16	11.125	14.625	12 7/8	3 7/16	2 3/8	4	1 1/8 - 7NC	75.6
XTH100	XTB100	17.940	3	13.688	17.500	15 9/16	4 1/8	2 3/16	6	1 1/8 - 7NC	122.0
XTH120	XTB120	20.940	3 1/2	16.188	20.500	18 3/16	4 13/16	2	8	1 1/8 - 7NC	189.0
<b>Type 2 - Hubs</b>											
XTH15F4	XTB15	3.855	1/4	2.000	3.625	2 7/16	9/16	-	4	1/4 - 20NC	1.2
XTH15F5	XTB15	4.805	1/4	2.000	4.625	2 7/16	9/16	-	4	1/4 - 20NC	1.7
XTH15F6	XTB15	5.815	1/4	2.000	5.500	2 7/16	9/16	-	4	1/4 - 20NC	2.3
XTH15F8	XTB15	7.807	1/4	2.000	2.875	2 7/16	11/16	-	4	1/4 - 20NC	3.8
XTH20F5	XTB20	4.805	1/4	2.688	3.688	3 3/16	13/16	-	4	5/16 - 18NC	1.8
XTH20F6	XTB20	5.815	1/4	2.688	3.688	3 3/16	13/16	-	4	5/16 - 18NC	2.4
XTH20F8	XTB20	7.807	1/4	2.688	3.688	3 3/16	13/16	-	4	5/16 - 18NC	3.9
XTH20F10	XTB20	9.827	5/16	2.688	3.688	3 3/16	13/16	-	4	5/16 - 18NC	7.0
XTH20F12	XTB20	11.847	5/16	2.688	3.688	3 3/16	13/16	-	4	5/16 - 18NC	9.7
XTH25F6	XTB25	5.815	5/16	3.188	4.313	3 3/4	1 1/8	-	4	3/8 - 16NC	3.4
XTH25F8	XTB25	7.807	5/16	3.188	4.313	3 3/4	1 1/8	-	4	3/8 - 16NC	5.3
XTH25F10	XTB25	9.827	5/16	3.188	4.313	3 3/4	1 1/8	-	4	3/8 - 16NC	7.8
XTH25F12	XTB25	11.847	5/16	3.188	4.313	3 3/4	1 1/8	-	4	3/8 - 16NC	10.5



**Table No. 3 — XT® BUSHING SPECIFICATIONS**

Bushing	Dimensions				Cap Screws		Wt. Lbs.
	L	U	H	S	No.	Size	
XTB15	1 1/8	3/8	2 7/8	5/32	4	1/4 x 1	.7
XTB20	1 13/32	15/32	3 3/4	7/32	4	5/16 x 1 1/4	1.5
XTB25	1 7/8	5/8	4 7/16	1/4	4	3/8 x 1 3/4	2.6
XTB30	2 1/16	11/16	5 5/16	9/32	4	7/16 x 1 1/2	4.2
XTB35	2 15/32	25/32	6 5/16	5/16	4	1/2 x 1 3/4	7.4
XTB40	2 13/16	7/8	7 1/8	3/8	4	9/16 x 2	10.5
XTB45	3 5/16	15/16	8	13/32	4	5/8 x 2 1/4	14.8
XTB50	3 3/4	1	10 1/8	15/32	4	3/4 x 2 1/2	27.8
XTB60	4 1/8	1 1/8	11 15/16	9/16	4	7/8 x 2 1/2	42.8
XTB70	4 11/16	1 5/16	13 15/16	5/8	4	1 x 3	66.3
XTB80	5 1/8	1 3/8	15 5/8	11/16	4	1 1/8 x 3 1/2	85.7
XTB100	6 3/16	1 9/16	17 15/16	11/16	6	1 1/8 x 3 1/2	146.0
XTB120	7 1/16	1 3/4	20 5/8	11/16	8	1 1/8 x 3 1/2	216.0

**Table No. 2  
RECOMMENDED WRENCH TORQUE**

XT Size	Wrench Torque (in. lbs.)	Cap Screw Size
15	95	1/4"
20	200	5/16"
25	350	3/8"
30	550	7/16"
35	840	1/2"
40	1200	9/16"
45	1680	5/8"
50	3000	3/4"
60	4800	7/8"
70	7200	1"
80	9000	1 1/8"
100	9000	1 1/8"
120	9000	1 1/8"

**Maintenance.** For the first month of operation inspect bushings and capscrews for proper seating at least once a week and thereafter during periodic shut downs.

**Table No. 4 — STOCK XT® BUSHINGS**

Bushing	Stock Bore	Keyseat	Key Supplied	
XTB15	5/8*, 3/4*, 7/8*	3/16 x 3/32	none	
	1*, 1 1/8*, 1 3/16*, 1 1/4*, 1 7/16*, 1 1/2*	1/4 x 1/8 3/8 x 1/8	none 3/8 x 5/16 x 1 1/8	
XTB20	3/4 1, 1 3/16, 1 1/4 1 7/16, 1 1/2, 1 11/16 1 15/16*, 2*	3/16" x 3/32" 1/4 x 1/8 3/8 x 3/16 1/2 x 3/16	none none none 1/2 x 7/16 x 1 3/8	
	XTB25	1, 1 3/16, 1 1/4 1 7/16, 1 1/2, 1 11/16 1 15/16, 2, 2 3/16* 2 7/16*	1/4 x 1/8 3/8 x 3/16 1/2 x 1/4 5/8 x 1/8	none none none 5/8 x 7/16 x 1 3/4
		XTB30	1 7/16, 1 1/2 1 15/16, 2 3/16 2 7/16, 2 11/16* 2 15/16*	3/8 x 3/16 1/2 x 1/4 5/8 x 5/16 3/4 x 3/16
XTB35			1 15/16, 2 3/16 2 7/16*, 2 11/16* 2 15/16* 3 7/16*	1/2 x 1/4 5/8 x 5/16 3/4 x 3/8 7/8 x 5/16
	XTB40		2 7/16 2 15/16 3 7/16* 3 15/16*	5/8 x 5/16 3/4 x 3/8 7/8 x 7/16 1 x 3/8
		XTB45	3 7/16 3 15/16* 4 7/16*	7/8 x 7/16 1 x 1/2 1 x 3/8
XTB50			3 15/16, 4 7/16 4 15/16	1 x 1/2 1 1/4 x 5/8
	XTB60		5 7/16, 5 1/2 5 15/16, 6	1 1/4 x 5/8 1 1/2 x 3/4
XTB70		6 7/16, 6 1/2 6 15/16, 7	1 1/2 x 3/4 1 3/4 x 3/4	none none
	XTB80	7 1/2 7 15/16, 8	1 3/4 x 3/4 2 x 3/4	none none
XTB100		8 1/2, 9 9 7/16, 9 1/2, 10	2 x 3/4 2 1/2 x 7/8	none none
	XTB120	10 1/2, 11 11 1/2, 12	2 1/2 x 7/8 3 x 1	none none

TAPERED BORE BUSHINGS



Table No. 6 — KEYWAY DIMENSIONS

BUSHING	STOCK BORE	BORE	BUSHING KEYWAY	SHAFT KEYWAY
W25 (2517)	1, 1 3/16,	15/16 to 1 1/4	1/4 x 1/8	1/4 x 1/8
	1 7/16, 1 1/2,	1 5/16 to 1 3/8	5/16 x 5/32	5/16 x 5/32
	1 11/16,	1 7/16 to 1 3/4	3/8 x 3/16	3/8 x 3/16
	1 15/16,	1 13/16 to 2 1/4	1/2 x 1/4	1/2 x 1/4
	2 3/16, 2 7/16	2 5/16 to 2 1/2	*5/8 x 3/16	5/8 x 5/16
K30 (3020)	1 7/16, 1 11/16,	1 5/16 to 1 3/8	5/16 x 5/32	5/16 x 5/32
	1 15/16,	1 7/16 to 1 3/4	3/8 x 3/16	3/8 x 3/16
	2 3/16, 2 7/16,	1 13/16 to 2 1/4	1/2 x 1/4	1/2 x 1/4
	2 11/16,	2 5/16 to 2 3/4	5/8 x 5/16	5/8 x 5/16
	2 15/16	2 13/16 to 3	*3/4 x 1/4	3/4 x 3/8
K35 (3535)	1 15/16	1 7/8 to 2 1/4	1/2 x 1/4	1/2 x 1/4
	2 3/16	2 5/16 to 2 3/4	5/8 x 5/16	5/8 x 5/16
	2 7/16	2 7/8 to 3 1/4	3/4 x 3/8	3/4 x 3/8
	2 15/16	3 5/16 to 3 1/2	*7/8 x 1/4	7/8 x 7/16
K40 (4040)	2 7/16	2 7/8 to 3 1/4	3/4 x 3/8	3/4 x 3/8
	2 15/16, 3 7/16,	3 3/8 to 3 5/8	7/8 x 7/16	7/8 x 7/16
	3 15/16	3 7/8 to 4	*1 x 1/4	1 x 1/2
K45 (4545)	3 7/16	2 7/8 to 3 1/4	3/4 x 3/8	3/4 x 3/8
	3 15/16	3 3/8 to 3 3/4	7/8 x 7/16	7/8 x 7/16
	4 7/16	3 7/8 to 4 1/4	1 x 1/2	1 x 1/2
		4 3/8 to 4 1/2	*1 x 1/4	1 x 1/2
K50 (5050)	3 15/16	3 3/8 to 3 5/8	7/8 x 7/16	7/8 x 7/16
	4 7/16	3 7/8 to 4 1/2	1 x 1/2	1 x 1/2
	4 15/16	4 7/8 to 5	*1 1/4 x 7/16	1 1/4 x 5/8
K60 (6050)		4 7/16	1 x 1/2	1 x 1/2
		4 15/16 to 5 7/16	1 1/4 x 5/8	1 1/4 x 5/8
K70 (7060)		5 15/16 to 6	1 1/2 x 3/4	1 1/2 x 3/4
		4 15/16 to 5 7/16	1 1/4 x 5/8	1 1/4 x 5/8
		5 15/16 to 6 1/2	1 1/2 x 3/4	1 1/2 x 3/4
K80 (8050)		6 15/16 to 7	1 3/4 x 3/4	1 3/4 x 3/4
		5 15/16 to 6 1/2	1 1/2 x 3/4	1 1/2 x 3/4
		6 15/16 to 7 1/2	1 3/4 x 3/4	1 3/4 x 3/4
		8	2 x 3/4	2 x 3/4

Table No. 5  
RECOMMENDED WRENCH TORQUE

Bushing No.	Screws	Wrench Torque* (In. Lbs)
1008 & 1108	1/4" Set Screws	55
1210, 1215 & 1310	3/8" Set Screws	175
1610 & 1615	3/8" Set Screws	175
2012	7/16" Set Screws	280
2517 & 2525	1/2" Set Screws	430
3020 & 3030	5/8" Set Screws	800
3535	1/2" Set Screws	1,000
4040	5/8" Set Screws	1,700
4545	3/4" Set Screws	2,450
5050	7/8" Set Screws	3,100
6050, 7060 & 8065	1 1/4" Set Screws	7,800
10085 & 120100	1 1/2" Set Screws	13,700

\* Key to be furnished for these sizes only.

**Maintenance.** For the first month of operation inspect bushings and cap screws for proper seating at least once a week and thereafter during periodic shut downs.



**Table No. 7  
RECOMMENDED WRENCH TORQUE**

QD HUB	WRENCH TORQUE (IN. LBS.)	WRENCH LENGTH (INCHES)	WRENCH PULL (LBS.)
SF	360	6	60
E	720	12	60
F	900	12	75
JS	1620	12	135
MS	2700	15	180
NS	3600	20	180
PS	5400	30	180
WS	7200	36	200
SS	9000	48	188

**Maintenance.** For first month of operation inspect bushings and cap screws for proper seating at least once a week and thereafter during periodic shut downs.

**Table No. 8 — KEYWAY DIMENSIONS**

BUSHING	STOCK BORES	BORE RANGE	BUSHING KEYWAY	SHAFT KEYWAY
SF	-	1/2 to 9/16	1/8 x 1/16	1/8 x 1/16
	-	5/8 to 7/8	3/16 x 3/32	3/16 x 3/32
	1, 1 3/16	15/16 to 1 1/4	1/4 x 1/8	1/4 x 1/8
	-	1 5/16 to 1 3/8	5/16 x 5/32	5/16 x 5/32
	1 7/16, 1 1/2, 1 11/16	1 7/16 to 1 3/4	3/8 x 3/16	3/8 x 3/16
	1 15/16, 2 3/16	1 13/16 to 2 1/4	1/2 x 1/4	1/2 x 1/4
	-	2 5/16 to 2 3/8	5/8 x 5/16	5/8 x 5/16
	2 7/16*	2 7/16 to 2 1/2	5/8 x 1/8	5/8 x 5/16
E	-	7/8	3/16 x 3/32	3/16 x 3/32
	-	15/16 to 1 1/4	1/4 x 1/8	1/4 x 1/8
	-	1 5/16	5/16 x 5/32	5/16 x 5/32
	1 7/16, 1 11/16	1 7/16 to 1 3/4	3/8 x 3/16	3/8 x 3/16
	1 15/16, 2 3/16	1 13/16 to 2 1/4	1/2 x 1/4	1/2 x 1/4
	2 7/16, 2 11/16	2 5/16 to 2 3/4	5/8 x 5/16	5/8 x 5/16
	2 15/16	2 13/16 to 2 15/16	3/4 x 1/8	3/4 x 3/8
	-	-	-	-
F	-	1 to 1 1/4	1/4 x 1/8	1/4 x 1/8
	-	1 5/16 to 1 3/8	5/16 x 5/32	5/16 x 5/32
	-	1 7/16 to 1 3/4	3/8 x 3/16	3/8 x 3/16
	1 15/16, 2 3/16	1 13/16 to 2 1/4	1/2 x 1/4	1/2 x 1/4
	2 7/16	2 5/16 to 2 3/4	5/8 x 5/16	5/8 x 5/16
	2 15/16	2 13/16 to 3 1/4	3/4 x 3/8	3/4 x 3/8
	-	3 5/16 to 3 1/8	7/8 x 7/16	7/8 x 7/16
	3 7/16*	3 7/16	7/8 x 3/16	7/8 x 7/16
JS	-	1 1/2 to 1 3/4	3/8 x 3/16	3/8 x 3/16
	-	1 13/16 to 2 1/4	1/2 x 1/4	1/2 x 1/4
	2 7/16	2 5/16 to 2 3/4	5/8 x 5/16	5/8 x 5/16
	2 15/16	2 13/16 to 3 1/4	3/4 x 3/8	3/4 x 3/8
	3 7/16	3 5/16 to 3 3/4	7/8 x 7/16	7/8 x 7/16
	-	3 13/16 to 3 7/8	1 x 1/2	1 x 1/2
3 15/16*	3 15/16	1 x 1/8	1 x 1/2	
MS	-	2 to 2 1/4	1/2 x 1/4	1/2 x 1/4
	-	2 5/16 to 2 3/4	5/8 x 5/16	5/8 x 5/16
	-	2 13/16 to 3 1/4	3/4 x 3/8	3/4 x 3/8
	3 7/16	3 5/16 to 3 3/4	7/8 x 7/16	7/8 x 7/16
3 15/16, 4 7/16	3 13/16 to 4 1/2	1 x 1/2	1 x 1/2	
NS	-	2 7/16 to 2 3/4	5/8 x 5/16	5/8 x 5/16
	-	2 13/16 to 3 1/4	3/4 x 3/8	3/4 x 3/8
	-	3 5/16 to 3 3/4	7/8 x 7/16	7/8 x 7/16
	-	3 13/16 to 4 1/2	1 x 1/2	1 x 1/2
4 15/16	4 9/16 to 5	1 1/4 x 5/8	1 1/4 x 5/8	
PS	-	2 15/16 to 3 1/4	3/4 x 3/8	3/4 x 3/8
	-	3 5/16 to 3 3/4	7/8 x 7/16	7/8 x 7/16
	-	3 13/16 to 4 1/2	1 x 1/2	1 x 1/2
	5 7/16	4 9/16 to 5 1/2	1 1/4 x 5/8	1 1/4 x 5/8
5 15/16*, 6*	5 9/16 to 6	1 1/2 x 1/4	1 1/2 x 3/4	
WS	-	4 7/16 to 4 1/2	1 x 1/2	1 x 1/2
	-	4 9/16 to 5 1/2	1 1/4 x 5/8	1 1/4 x 5/8
	5 15/16, 6, 6 1/2	5 9/16 to 6 1/2	1 1/2 x 3/4	1 1/2 x 3/4
	7	6 9/16 to 7	1 3/4 x 3/4	1 3/4 x 3/4
	7 1/2*	7 1/16 to 7 1/2	1 3/4 x 1/4	1 3/4 x 3/4
8*	7 9/16 to 8	2 x 1/4	2 x 3/4	
SS	-	6 to 6 1/2	1 1/2 x 3/4	1 1/2 x 3/4
	-	6 9/16 to 7 1/2	1 3/4 x 3/4	1 3/4 x 3/4
	8	7 9/16 to 8 1/4	2 x 3/4	2 x 3/4
	8 1/2*, 9*	8 5/16 to 9	2 x 3/4	2 x 3/4
	9 1/2*, 10*	9 1/16 to 10	2 1/2 x 1/4	2 1/2 x 7/8

\* Key to be furnished for these sizes only.



## HEAVY DUTY REINFORCED

The VAN GORP® H•D•R® Rims of pulleys 14" in diameter and larger are formed in custom-designed crowning rolls by a cold "forming" process that increases the strength of the steel. They feature two-rim-half construction, an exclusive, perfected technique that permits the use of internal discs in crown and straight face pulleys...and thereby creates a stronger, more rounded finished pulley product. End discs are cut to micrometer calibration. Rims, discs and hubs are all steel and are fused together by a deep penetrating, submerged arc welding process with back-up bars used under the longitudinal rim welds. The result? A continuously welded drum construction, with its built-in barrier against dirt, water and steam; less maintenance; extended pulley service; **and most important, a dramatic reduction in radial deformation and longitudinal deflection in the rim.**

### Part Number Example

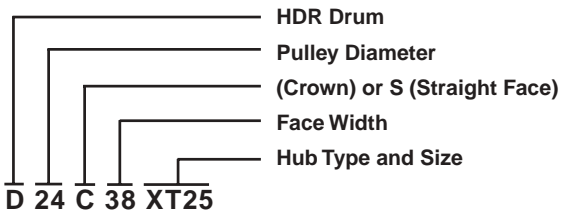

Radial deformation is a particularly serious problem when a pulley is used in a low arc of contact and high tension application. The addition of internal discs, plus heavier-than-standard construction, not only permits a VAN GORP® H•D•R® Pulley to work on any arc of contact, but also increases its moment of inertia...giving it additional strength and rigidity while decreasing the degree of longitudinal deflection. Pulleys 14" in diameter and larger, 26"-44" wide have one internal disc; pulleys 46"-64" wide have two internal discs; and pulleys 65" and wider have three or more internal discs.



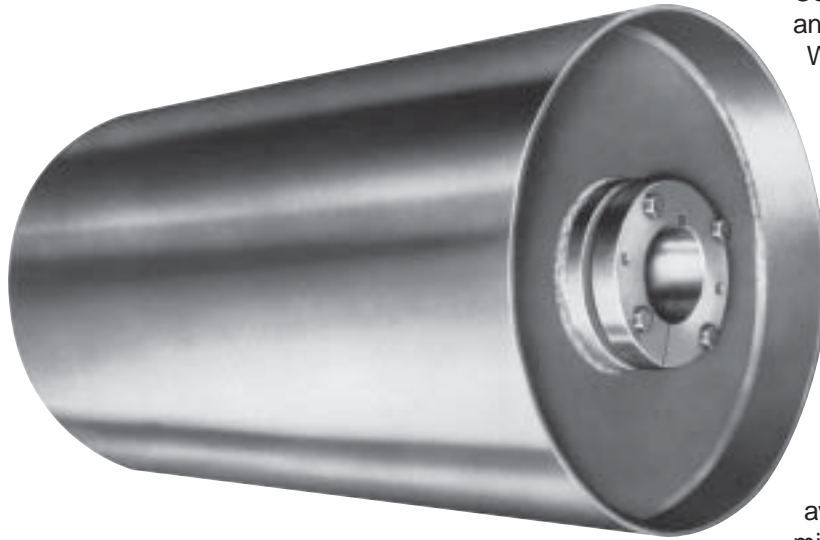

Conveyor systems today are moving faster and carrying higher tonnage than ever before. When these systems need drum pulleys which exceed normal ANSI/CEMA service factors, an XT-reme™ solution is required.

The VAN GORP® XT-reme™ drum pulley is designed with heavier end discs than normal ANSI/CEMA designed pulleys. They have been designed for longer life with heavy end discs (rigid design) to minimize end disc stress due to shaft bending.

The XT-reme™ drum features the VAN GORP® XT® hub which is the premier hub and bushing system available for conveyor pulleys. The XT® hub minimizes end disc pre-stress by using a unique 2 inch per foot self locking taper. Less pre-stress means that the XT-reme™ drum will run longer with less chance of down time than with other types of conveyor pulleys.

The XT-reme™ drum is available in diameters ranging from 10 to 60 and face widths to 76. Many types of lagging are available including SBR, Neoprene and Static Conductive Neoprene.



**Part Number Example**

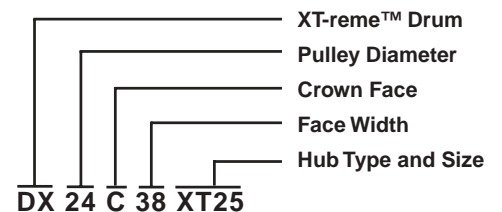

Mine Duty drum pulleys were originally designed for the underground coal industry for longwall mining. Longwall conveyors have belt tensions that change depending on the varying length of the conveyor. The conveyor gets longer as it is extended along the cut in the coal seam. The uncertainty in the loading conditions leads to a conveyor pulley design that is actually stronger than the shaft it is mounted on.

Because of their heavy duty construction and proven track record in the underground industry, mine duty pulleys are often used above ground to take advantage of their added service factor. VAN GORP® standard mine duty pulleys are available in diameters ranging from 12" to 60" and face widths to 76". Many types of lagging are available including SBR, Neoprene and Static Conductive Neoprene.

There are no ANSI/CEMA standards that govern the load ratings or material thickness of Mine Duty pulleys. The following chart compares the additional service factor that the VAN GORP® Mine Duty has compared to the ANSI/CEMA ratings for a standard pulley.



Table No. 9

Pulley Size	Shaft Diameter	Bearing Centers	ANSI/CEMA Load Rating	Mine Duty Service Factor
14 X 26	3 7/16"	32"	11,600	1.58
18 X 32	4 7/16"	40"	19,000	2.06
24 X 44	5 7/16"	54"	26,600	2.01
36 X 57	7"	69"	49,000	2.19

Part Number Example

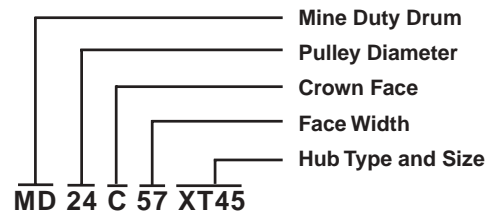

NOTE: The ANSI/CEMA ratings represents the maximum load for the shaft for a 8,000 psi bending stress. The service factor represents the ratio of the pulley load rating to the shaft load rating.



VAN GORP's Turbine Discs are "State-of-the-Art" conveyor pulleys used on high tonnage steel cable belt systems where belt tensions can often exceed 200,000 pounds. These systems require a special pulley designed to minimize the inherent stresses in a pulley which result from the rolling and welding processes during fabrication. The integral hub-end disc turbine replaces the critical hub to end disc welds of a regular drum pulley with a large transitional radius designed to minimize stress. The only weld on the end disc is where it is welded to the rim which is at the lowest stress point of the end disc.



Turbine Disc Drum Pulleys are available from VAN GORP with keyless locking assemblies up to 27 1/2" bore.

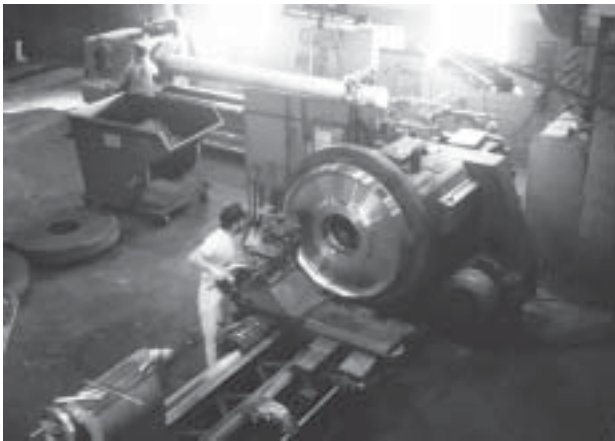



ENGINEERED CONVEYOR PULLEY

VAN GORP  
 BOX288  
 PELLA, IOWA 50129

SERIALNUMBER:

All Double Drum and Turbine Type End Disc Pulleys are provided with a Serialized Metal Tag.

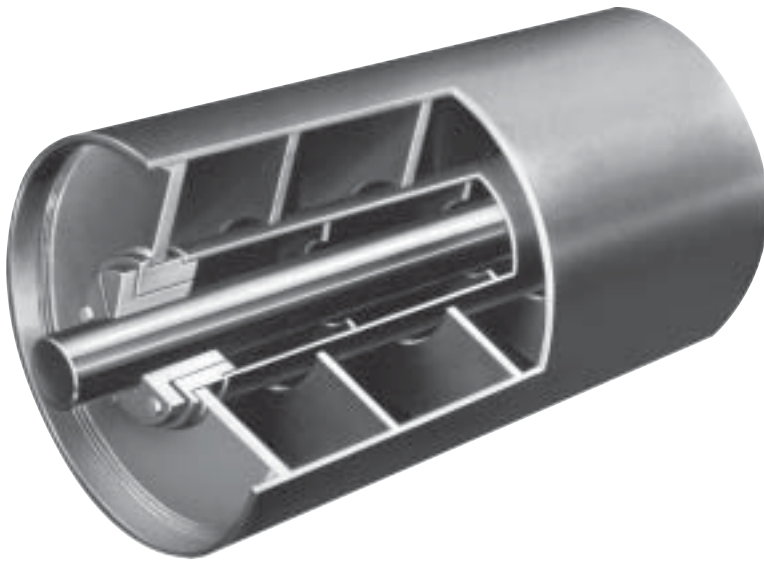

Available on  
XT®, Tapered Bore, Q-D®  
**KEYLESS LOCKING  
ASSEMBLIES.**

**SPECIAL TWO YEAR WARRANTY**

## Van Gorp® DOUBLE DRUM™

### WARRANTY

We warrant our Double Drum™ pulleys against defects in material or workmanship for a period of two years from date of shipment. It is required that you have filled in a data sheet for each pulley. The

Double Drum™ pulley shall be installed in accordance with manufacturer's recommendations; the loads shall not exceed the information you have listed on the data sheet and operated under normal conditions. Whenever, under the warranty, it is necessary for you to replace parts or pulleys, VAN GORP shall furnish such items free of charge, F.O.B., Pella, Iowa.

No allowance will be made for any expense incurred in repairing or replacing defective pulleys, or supplying any missing parts, except on the written consent of VAN GORP.

## REINFORCED DRUM-WITHIN-A-DRUM DESIGN SAVES YOU A TON ON YOUR CONVEYOR SYSTEM!

The most sophisticated conveyor system in the world isn't worth a dime when it's down. And yet, the obvious trend towards larger, more complex, more demanding systems calls for improvements in technology and engineering throughout the entire system...and the application of these improvements.

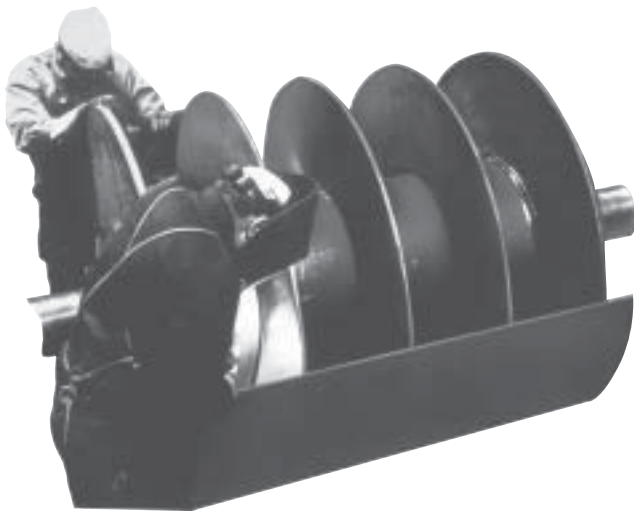

This is especially true in the area of conveyor pulleys. For example, in recent years, modern, high tonnage conveyor systems and the increased use of belting reinforced with steel cables have created forces not previously considered in present pulley design. The result? Pulley failure. Consequently, there has been sufficient cause for engineers to design to more conservative stress and deflection levels. In fact, until more accurate field testing and feedback from existing applications can be accumulated, **the most practical way to avoid premature failures is by designing to these lower stress and deflection levels.**

The VAN GORP® Double Drum™ Pulley is in a class by itself. It is engineered to meet these demanding loading conditions and has established an impressive performance rating from many satisfied customers. In fact, with hundreds of Double Drum™ Pulleys presently in service all over the world, it has proven itself in both design and performance. The reason? A unique drum-within-a-drum design that decreases end disc slope and minimizes stress at both rim end and hub end disc locations. A pulley design that decreases shaft deflection between hubs and prevents pre-stressing the end discs when assembling taper type hubs. A pulley matched to your conveyor's maximum capacity; then built by a precision-engineered, "two-rim-half" process that many have never considered nor taken time to imitate.

In many applications end discs can be held to a much more practical thickness which actually results in a lighter and more economical pulley than those with heavier end discs.

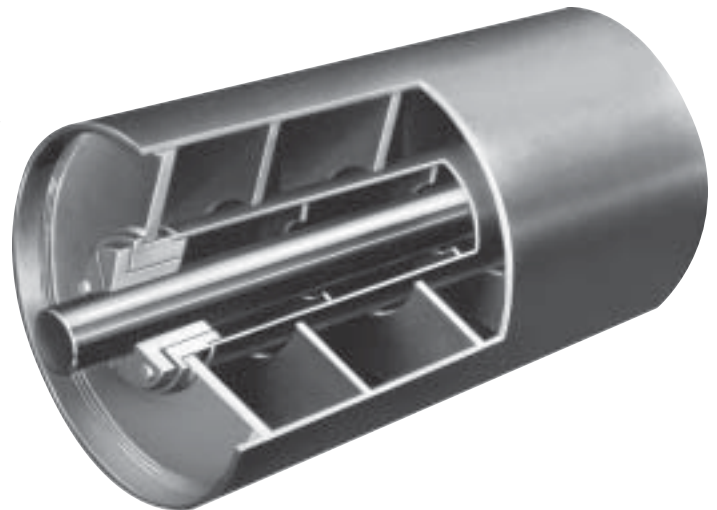

The VAN GORP® Double Drum™ Pulley ...**saves you a ton on your conveyor system.** In fact, we guarantee it...for two full years.



American Made

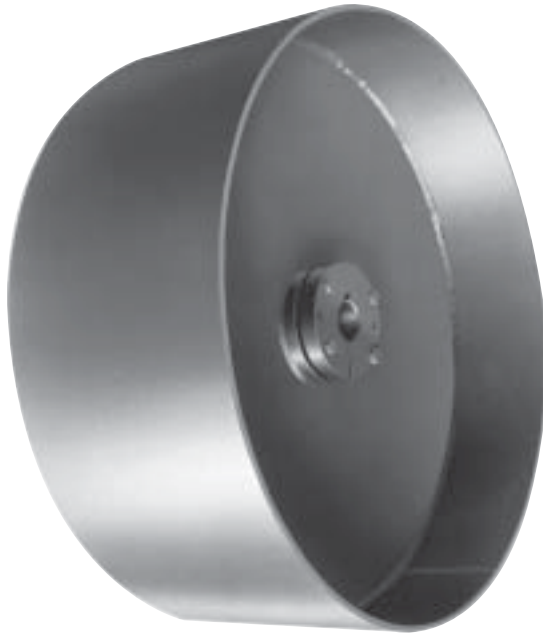

### Part Number Example

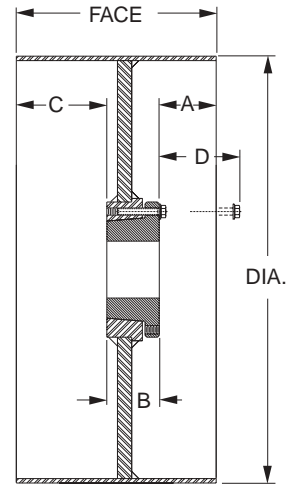
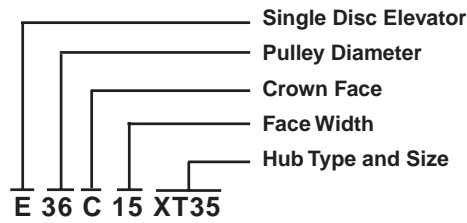

With continuously welded disc-to-rim construction and compression type hubs, VAN GORP has turned the weak link in most elevator conveyor systems into the strong point. Now, you get a super strength, one piece, single disc steel elevator pulley, superior to any other on the market today.

Here's why: with a VAN GORP® Pulley, you get a stronger, heavy-duty component...with high compression hub and bushing. (The XT® hub and bushing was selected because XT® holding power is unequalled in pulley applications...and "pulley walking" on the shaft IS NOT a common problem with this hub design.) Intermittent welding of the disc to the rim is common in most elevator pulleys. However, at VAN GORP, we continuously weld the disc to the rim. Plus, the leading and trailing edges of the rim are formed before rolling. This forming process minimizes the rim seam's flat spot.

**Table No. 23 — Bushing Location Dimensions**

Dia.	Bushing	8" Face Width Dimensions				9" Face Width Dimensions				11" Face Width Dimensions				13" Face Width Dimensions				15" Face Width Dimensions				16" Face Width Dimensions			
		A	B	C	D	A	B	C	D	A	B	C	D	A	B	C	D	A	B	C	D	A	B	C	D
16"	XTB20	3 1/32	1 13/32	3 9/16	1 7/16	3 17/32	1 13/32	4 1/16	1 7/16	4 17/32	1 13/32	5 1/16	1 7/16	5 17/32	1 13/32	6 1/16	1 7/16	6 17/32	1 13/32	7 1/16	1 7/16	7 1/32	1 13/32	7 9/16	1 7/16
	XTB25	2 13/16	1 7/8	3 5/16	1 31/32	3 5/16	1 7/8	3 13/16	1 31/32	4 5/16	1 7/8	4 13/16	1 31/32	5 5/16	1 7/8	5 13/16	1 31/32	6 5/16	1 7/8	6 13/16	1 31/32	6 13/16	1 7/8	7 5/16	1 31/32
	XTB30	2 11/16	2 1/16	3 1/4	1 25/32	3 3/16	2 1/16	3 3/4	1 25/32	4 3/16	2 1/16	4 3/4	1 25/32	5 3/16	2 1/16	5 3/4	1 25/32	6 3/16	2 1/16	6 3/4	1 25/32	6 11/16	2 1/16	7 1/4	1 25/32
	XTB35	2 15/32	2 15/32	3 1/16	2 1/16	2 31/32	2 15/32	3 9/16	2 1/16	3 31/32	2 15/32	4 9/16	2 1/16	4 31/32	2 15/32	5 9/16	2 1/16	5 31/32	2 15/32	6 9/16	2 1/16	6 15/32	2 15/32	7 1/16	2 1/16
	XTB40	2 5/16	2 13/16	2 7/8	2 11/32	2 13/16	3 3/8	2 11/32	3 13/16	2 13/16	4 3/8	2 11/32	4 13/16	2 13/16	5 3/8	2 11/32	5 13/16	2 13/16	6 3/8	2 11/32	6 6/16	2 13/16	6 7/8	2 11/32	
18	XTB20	3 1/32	1 13/32	3 9/16	1 7/16	3 17/32	1 13/32	4 1/16	1 7/16	4 17/32	1 13/32	5 1/16	1 7/16	5 17/32	1 13/32	6 1/16	1 7/16	6 17/32	1 13/32	7 1/16	1 7/16	7 1/32	1 13/32	7 9/16	1 7/16
	XTB25	2 13/16	1 7/8	3 5/16	1 31/32	3 5/16	1 7/8	3 13/16	1 31/32	4 5/16	1 7/8	4 13/16	1 31/32	5 5/16	1 7/8	5 13/16	1 31/32	6 5/16	1 7/8	6 13/16	1 31/32	6 13/16	1 7/8	7 5/16	1 31/32
	XTB30	2 11/16	2 1/16	3 1/4	1 25/32	3 3/16	2 1/16	3 3/4	1 25/32	4 3/16	2 1/16	4 3/4	1 25/32	5 3/16	2 1/16	5 3/4	1 25/32	6 3/16	2 1/16	6 3/4	1 25/32	6 11/16	2 1/16	7 1/4	1 25/32
	XTB35	2 15/32	2 15/32	3 1/16	2 1/16	2 31/32	2 15/32	3 9/16	2 1/16	3 31/32	2 15/32	4 9/16	2 1/16	4 31/32	2 15/32	5 9/16	2 1/16	5 31/32	2 15/32	6 9/16	2 1/16	6 15/32	2 15/32	7 1/16	2 1/16
	XTB40	2 15/16	2 15/16	2 7/8	2 11/32	2 13/16	3 3/8	2 11/32	3 13/16	2 13/16	4 3/8	2 11/32	4 13/16	2 13/16	5 3/8	2 11/32	5 13/16	2 13/16	6 3/8	2 11/32	6 6/16	2 13/16	6 7/8	2 11/32	
20	XTB25	2 25/32	1 7/8	3 11/32	1 31/32	3 9/32	1 7/8	3 27/32	1 31/32	4 9/32	1 7/8	4 27/32	1 31/32	5 9/32	1 7/8	5 27/32	1 31/32	6 6/32	1 7/8	6 27/32	1 31/32	6 25/32	1 7/8	7 11/32	1 31/32
	XTB30	2 21/32	2 1/16	3 9/32	1 25/32	3 5/32	2 1/16	3 25/32	1 25/32	4 5/32	2 1/16	4 25/32	1 25/32	5 5/32	2 1/16	5 25/32	1 25/32	6 5/32	2 1/16	6 25/32	1 25/32	6 21/32	2 1/16	7 9/32	1 25/32
	XTB35	2 7/16	2 15/32	3 3/32	2 1/16	2 15/16	2 15/32	3 19/32	2 1/16	3 15/16	2 15/32	4 19/32	2 1/16	4 15/16	2 15/32	5 19/32	2 1/16	5 15/16	2 15/32	6 19/32	2 1/16	6 17/16	2 15/32	7 3/32	2 1/16
	XTB40	2 9/32	2 13/16	2 29/32	2 11/32	2 25/32	2 13/16	3 13/32	2 11/32	3 25/32	2 13/16	4 13/32	2 11/32	4 25/32	2 13/16	5 13/32	2 11/32	5 25/32	2 13/16	6 13/32	2 11/32	6 9/32	2 13/16	6 29/32	2 11/32
	XTB45	2 1/32	3 5/16	2 21/32	2 5/8	2 17/32	3 5/16	3 5/32	2 5/8	3 17/32	3 5/16	4 5/32	2 5/8	4 17/32	3 5/16	5 5/32	2 5/8	5 17/32	3 5/16	6 5/32	2 5/8	6 1/32	3 5/16	6 21/32	2 5/8
24	XTB30	2 21/32	2 1/16	3 9/32	1 25/32	2 5/32	2 1/16	3 25/32	1 25/32	4 5/32	2 1/16	4 25/32	1 25/32	5 5/32	2 1/16	5 25/32	1 25/32	6 5/32	2 1/16	6 25/32	1 25/32	6 21/32	2 1/16	7 9/32	1 25/32
	XTB35	2 7/16	2 15/32	3 3/32	2 1/16	2 15/16	2 15/32	3 19/32	2 1/16	3 15/16	2 15/32	4 19/32	2 1/16	4 15/16	2 15/32	5 19/32	2 1/16	5 15/16	2 15/32	6 19/32	2 1/16	6 17/16	2 15/32	7 3/32	2 1/16
	XTB40	2 9/32	2 13/16	2 29/32	2 11/32	2 25/32	2 13/16	3 13/32	2 11/32	3 25/32	2 13/16	4 13/32	2 11/32	4 25/32	2 13/16	5 13/32	2 11/32	5 25/32	2 13/16	6 13/32	2 11/32	6 9/32	2 13/16	6 29/32	2 11/32
	XTB45	2 1/32	3 5/16	2 21/32	2 5/8	2 17/32	3 5/16	3 5/32	2 5/8	3 17/32	3 5/16	4 5/32	2 5/8	4 17/32	3 5/16	5 5/32	2 5/8	5 17/32	3 5/16	6 5/32	2 5/8	6 1/32	3 5/16	6 21/32	2 5/8
	XTB50	1 13/16	3 3/4	2 7/16	2 31/32	2 5/16	3 3/4	2 15/16	2 31/32	3 5/16	3 3/4	3 15/16	2 31/32	4 5/16	3 3/4	4 15/16	2 31/32	5 5/16	3 3/4	5 15/16	2 31/32	5 13/16	3 3/4	6 7/16	2 31/32
30	XTB35	2 13/32	2 15/32	3 1/8	2 1/16	2 29/32	2 15/32	3 5/8	2 1/16	3 29/32	2 15/32	4 5/8	2 1/16	4 29/32	2 15/32	5 5/8	2 1/16	5 29/32	2 15/32	6 5/8	2 1/16	6 13/32	2 15/32	7 1/8	2 1/16
	XTB40	2 1/4	2 13/16	2 15/16	2 11/32	2 3/4	2 13/16	3 7/16	2 11/32	3 3/4	2 13/16	4 7/16	2 11/32	4 3/4	2 13/16	5 7/16	2 11/32	5 3/4	2 13/16	6 7/16	2 11/32	6 1/4	2 13/16	6 15/16	2 11/32
	XTB45	2	3 5/16	2 11/16	2 5/8	2 1/2	3 5/16	3 3/16	2 5/8	3 1/2	3 5/16	4 3/16	2 5/8	4 1/2	3 5/16	5 3/16	2 5/8	5 1/2	3 5/16	6 3/16	2 5/8	6	3 5/16	6 11/16	2 5/8
	XTB50	1 13/16	3 3/4	2 7/16	2 31/32	2 5/16	3 3/4	2 15/16	2 31/32	3 5/16	3 3/4	3 15/16	2 31/32	4 5/16	3 3/4	4 15/16	2 31/32	5 5/16	3 3/4	5 15/16	2 31/32	5 13/16	3 3/4	6 7/16	2 31/32
	XTB60	1 9/16	4 1/8	2 5/16	3 1/32	2 1/16	4 1/8	2 13/16	3 1/32	3 1/16	4 1/8	3 13/16	3 1/32	4 1/16	4 1/8	4 13/16	3 1/32	5 1/16	4 1/8	5 13/16	3 1/32	5 9/16	4 1/8	6 5/16	3 1/32
36	XTB35	2 13/32	2 15/32	3 1/8	2 1/16	2 29/32	2 15/32	3 5/8	2 1/16	3 29/32	2 15/32	4 5/8	2 1/16	4 29/32	2 15/32	5 5/8	2 1/16	5 29/32	2 15/32	6 5/8	2 1/16	6 13/32	2 15/32	7 1/8	2 1/16
	XTB40	2 1/4	2 13/16	2 15/16	2 11/32	2 3/4	2 13/16	3 7/16	2 11/32	3 3/4	2 13/16	4 7/16	2 11/32	4 3/4	2 13/16	5 7/16	2 11/32	5 3/4	2 13/16	6 7/16	2 11/32	6 1/4	2 13/16	6 15/16	2 11/32
	XTB45	2	3 5/16	2 11/16	2 5/8	2 1/2	3 5/16	3 3/16	2 5/8	3 1/2	3 5/16	4 3/16	2 5/8	4 1/2	3 5/16	5 3/16	2 5/8	5 1/2	3 5/16	6 3/16	2 5/8	6	3 5/16	6 11/16	2 5/8
	XTB50	1 13/16	3 3/4	2 7/16	2 31/32	2 5/16	3 3/4	2 15/16	2 31/32	3 5/16	3 3/4	3 15/16	2 31/32	4 5/16	3 3/4	4 15/16	2 31/32	5 5/16	3 3/4	5 15/16	2 31/32	5 13/16	3 3/4	6 7/16	2 31/32
	XTB60	1 9/16	4 1/8	2 5/16	3 1/32	2 1/16	4 1/8	2 13/16	3 1/32	3 1/16	4 1/8	3 13/16	3 1/32	4 1/16	4 1/8	4 13/16	3 1/32	5 1/16	4 1/8	5 13/16	3 1/32	5 9/16	4 1/8	6 5/16	3 1/32
42	XTB35	2 13/32	2 15/32	3 1/8	2 1/16	2 29/32	2 15/32	3 5/8	2 1/16	3 29/32	2 15/32	4 5/8	2 1/16	4 29/32	2 15/32	5 5/8	2 1/16	5 29/32	2 15/32	6 5/8	2 1/16	6 13/32	2 15/32	7 1/8	2 1/16
	XTB40	2 1/4	2 13/16	2 15/16	2 11/32	2 3/4	2 13/16	3 7/16	2 11/32	3 3/4	2 13/16	4 7/16	2 11/32	4 3/4	2 13/16	5 7/16	2 11/32	5 3/4	2 13/16	6 7/16	2 11/32	6 1/4	2 13/16	6 15/16	2 11/32
	XTB45	2	3 5/16	2 11/16	2 5/8	2 1/2	3 5/16	3 3/16	2 5/8	3 1/2	3 5/16	4 3/16	2 5/8	4 1/2	3 5/16	5 3/16	2 5/8	5 1/2	3 5/16	6 3/16	2 5/8	6	3 5/16	6 11/16	2 5/8
	XTB50	1 13/16	3 3/4	2 7/16	2 31/32	2 5/16	3 3/4	2 15/16	2 31/32	3 5/16	3 3/4	3 15/16	2 31/32	4 5/16	3 3/4	4 15/16	2 31/32	5 5/16	3 3/4	5 15/16	2 31/32	5 13/16	3 3/4	6 7/16	2 31/32
	XTB60	1 9/16	4 1/8	2 5/16	3 1/32	2 1/16	4 1/8	2 13/16	3 1/32	3 1/16	4 1/8	3 13/16	3 1/32	4 1/16	4 1/8	4 13/16	3 1/32	5 1/16	4 1/8	5 13/16	3 1/32	5 9/16	4 1/8	6 5/16	3 1/32

Contact factory if other hubs required

**ROUGH TOP LAGGING**



Rough Top Rubber Lagging is available in either **vulcanized** or **bolt on**.

**Vulcanized Rough Top** is 60±5 durometer Shore A, SBR Black Rubber. It is bonded directly to the pulley rim in the vulcanizing process.

**Bolt on Rough Top** Lagging material is applied to the pulley rim which is coated with a special bonding adhesive and fastened to the pulley rim with strong self tapping screws at the beginning and end of the lagging.

The top cover of both types of Rough top has thousand of fingers that grip the belt. This irregular surface increases the rubber's tractive capacity and helps keep the rubber clean.

**SLIDE-LAG®**



Quality rubber is bonded to special traction pads fitting the pulley rim. The pads slide into retainers welded into the pulley rim. New pads can easily be replaced without removing the pulley from the conveyor.

Slide-Lag® is a registered trademark of Holz Rubber Co., Inc.

**VULCANIZED RUBBER LAGGING AND GROOVING**



Vulcanized rubber lagging is 60±5 durometer Shore A, S.B.R. black rubber without a cloth fabric. It is bonded directly to the pulley rim in the vulcanizing process. The finished rubber surface has a cloth impression. When **GROOVING** is required, please specify whether herringbone or another type of grooving is desired. Normally, grooving should not be used in vulcanized rubber less than 3/8" thick.

**NOTE:** Direction of grooving must be stated if we supply the lagging and install a shaft. Normally grooving should be run with the apex of the pattern leading.

**VULCANIZED LAGGING TOLERANCES**

**PLAIN WRAPPED CLOTH IMPRESSION LAGGING:** ± 1/8" on rubber thickness—no concentricity tolerance guaranteed.

If you have an application for lagged pulleys that demands exact concentricity, such as some elevator pulleys, slide bed or reversing conveyor pulleys, then we suggest that you order machined lagged pulleys. True, this will cost more initially; however, in a tough application, this cost would be offset quickly by additional necessary labor when trying to train the belt.

**Part Number Example**

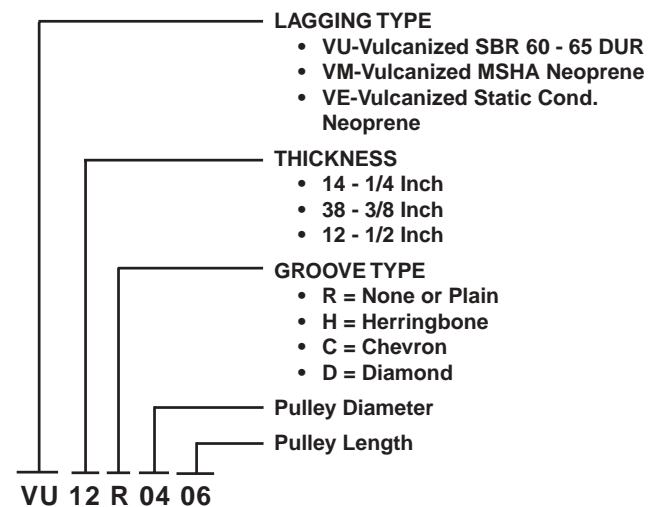

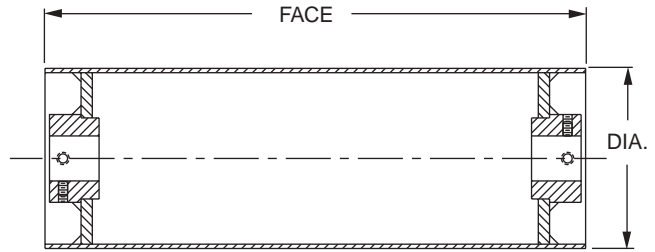

### Part Number Example

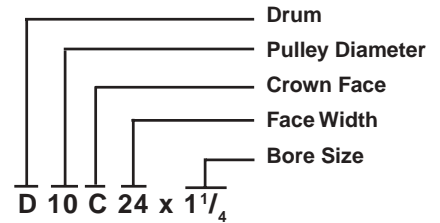

VAN GORP® Finished Bore Conveyor Pulleys are designed to meet the demands for all types of package handling conveyor service including mail handling, bag handling and various warehousing requirements. They are constructed of Steel Tubing mechanically expanded to insure a true crown, with end discs continuously welded to rims to exclude foreign material. Straight Face Pulleys are also available; Crown Face supplied unless otherwise specified.

**Table No. 27 — Standard Sizes and Weights**

Pulley Dia.	Face Width - Average Weight in Pounds									
	6"	8"	10"	12"	14"	16"	18"	20"	22"	24"
4"	4	5	6	6	7	7	8	8	9	10
5	8	9	10	11	12	13	14	15	16	17
6	9	11	12	13	14	16	17	18	19	21
8	17	19	21	22	24	26	28	30	32	34
10	24	27	29	32	34	36	39	41	43	45

Pulley Dia.	Face Width - Average Weight in Pounds									
	26"	28"	30"	32"	34"	36"	38"	40"	42"	44"
4"	10	11	12	12	13	13	14	14	15	15
5	18	19	20	21	22	23	25	26	27	28
6	22	23	24	26	27	28	29	31	32	33
8	36	38	40	42	43	45	47	49	51	53
10	48	51	53	55	58	60	63	65	67	70

## Stock Machined Crowned Conveyor Pulleys — Finished Bore

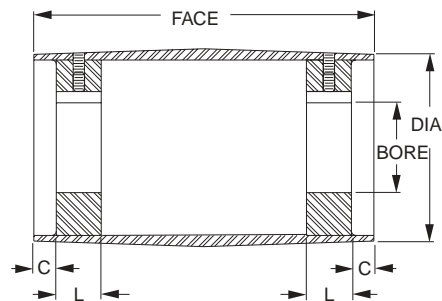
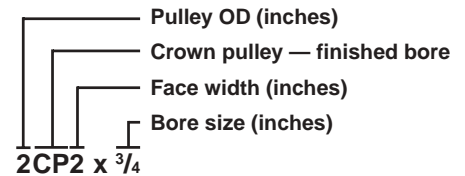

**Type 2**

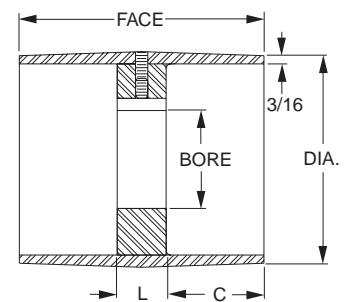

**Type 1**

**Table No. 28 — Specifications**

Part No.	Type	Stock Bore Marked "X"			Dimensions				Wt.-Lbs.
		3/8	3/4	1	Dia.	Face	L	C	
2CP2	1	X	X	-	2"	2"	1"	7/16"	1.5
2CP3	1	X	X	-	2	3	1	15/16	1.7
2CP4	1	X	X	X	2	4	1	1 7/16	1.9
3CP2	1	X	X	-	3	2	1	7/16	2.4
3CP3	1	X	X	X	3	3	1	15/16	2.7
3CP4	1	X	X	X	3	4	1	1 7/16	3.0
3CP5	2	X	X	X	3	5	1	1/2	4.3

**Table No. 29  
Standard Keyseats**

Bore Range	Keyseat
5/8" - 7/8"	3/16" x 3/32"
15/16 - 1	1/4 x 1/8

True Turn®  
Machined Face



Bushing Location Dimensions

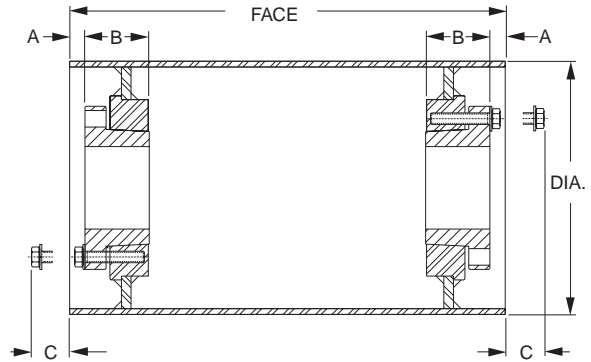

Built with heavy wall tubing and machined in a lathe, all VAN GORP® True Turn® Conveyor Pulleys undergo a quality, precision method of construction that results in a heavy-duty pulley, machined for close tolerance and accurate pulley concentricity.

Each component has been built to an exact manufacturing requirement. A jig is used to properly position the hubs and end discs inside the tube. The components are firmly secured in this jugged position and all necessary bonding welds are completed. This jiggling method, plus the use of high-quality steel throughout, ensures you of a continuously welded drum pulley construction, with maximum strength to weight ratio, true concentricity, and the virtual elimination of maintenance problems resulting from dirt, water and steam.

Available in 4" -5" -6" -8" diameter sizes.

Table No. 30  
XT® Bushings

Bushing	Dimensions		
	A	B	C
XT15	3/4	1 1/8	7/16
XT20	11/16	1 13/32	3/4
XT25	1/2	1 7/8	1 1/2

Part Number Example

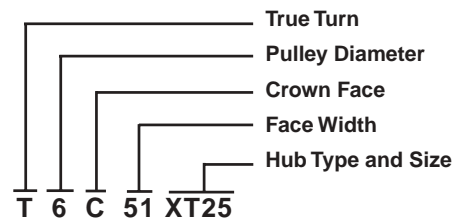

True Turn® Pulleys with Q-D® and Tapered Bore Bushings are available on application. Contact the Factory.

Custom Designed Pulleys for Package Handling

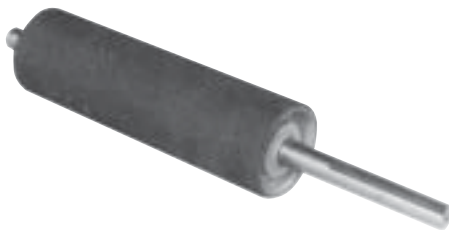

Your design or ours?

We will design pulleys to meet your application needs, or we will manufacture to your prints and specifications.



American Made

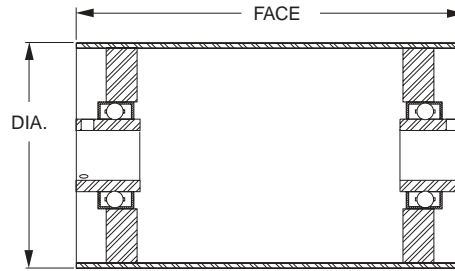

VAN GORP® CONVEYOR ROLLERS ARE DESIGNED TO MEET THE DEMANDS FOR ALL TYPES OF PACKAGE HANDLING CONVEYOR SERVICE INCLUDING MAIL HANDLING, BAG HANDLING AND VARIOUS WAREHOUSING REQUIREMENTS.

These conveyor rollers are constructed of steel tubing mechanically expanded to insure a true crown, with end disc continuously welded to rims to exclude foreign material. Straight face pulleys are also available. Crown face will be supplied unless specified otherwise.

**Table No. 31 — Standard Sizes & Weights**

Pulley Dia.	Bore Range	Face Width - Average Weight in Pounds								
		10	12	14	16	18	20	22	24	26
4	1/2-1 7/16	7	8	9	9	10	10	11	11	12
5	1/2-1 7/16	13	14	15	16	17	18	19	20	21
6	1/2-1 15/16	17	18	20	21	22	23	25	26	27
8	1/2-1 15/16	29	31	33	35	37	39	41	42	44

Pulley Dia.	Bore Range	Face Width - Average Weight in Pounds								
		28	30	32	34	36	38	40	42	44
4	1/2-1 7/16	13	13	14	14	15	15	16	17	17
5	1/2-1 7/16	22	23	24	25	26	27	28	29	30
6	1/2-1 15/16	28	30	31	32	34	35	36	37	38
8	1/2-1 15/16	46	48	50	52	54	56	58	59	61

### Rollers with ER Bearings

VAN GORP also offers rollers built to your specifications or designed by our engineers to meet your application needs. Standard rollers are available in diameters of 2 1/8", 2 3/4", 3 1/2" and 4 1/2" with face widths 18" to 60".

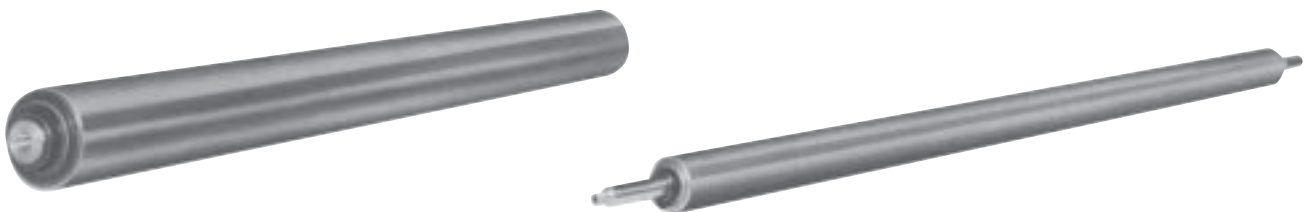

Rollers are available with standard crown, trapazoidal crown, and straight faces.

VAN GORP's® Dead-Shaft Pulleys use a removable piloted flange bearing that easily fits over the shaft and bolts to the end-disc of the conveyor pulley. Dead-Shaft Pulleys can be made in a variety of drum and wing pulley sizes to fit the needs of the application.



Dead shaft pulleys are different from traditional pulleys. The shaft is held fixed (dead) and not allowed to rotate. The pulley is mounted on bearings and rotates around the fixed shaft.

There are several advantages to this design:

- The shaft does not rotate so there is no rotational shaft fatigue.
- Shaft and bearing diameters can be downsized from traditional designs.
- Reduced pulley stress because self-aligning bearings absorb the shaft bending moment so it is not transmitted to the pulley end discs.
- Pre-stressing of pulley end discs during the shaft mounting process caused by bushings is eliminated.
- Piloted flange bearings are well known commercial brands and readily available if they need to be replaced.

Contact the VAN GORP® engineering department for additional information on how these unique pulleys can be used in you're application.

1-800-VAN-GORP or [vangorp@vangorp.biz](mailto:vangorp@vangorp.biz)

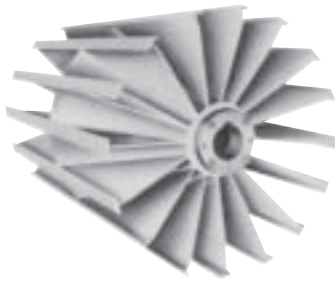

## Turn Clean™ Wing Pulleys

**REDUCES CLEANING PROBLEMS —  
PROTECTS CONVEYOR BELTS**

If you've ever cleaned off material build-up from a solid face pulley, you can appreciate the expense and the danger involved. That's why VAN GORP built the exclusive TURN CLEAN™ Pulley. Pulley rotation automatically starts the self-cleaning action, discharging foreign material to the side of the conveyor. Its strong double cone design features individual gussets welded continuously to each wing and hub for longer life. This unique

construction prevents belt misalignment and belt wear because it reduces the possibility of material between the belt and pulley.

Formed contact bars, which are welded to each wing, are the only pulley parts that come in contact with the belt, creating a self-cleaning action which reduces belt strain and wear.

Available in standard sizes from 8" to 36" in diameter and face widths from 12" to 76". Custom pulleys also made to your specifications.

### Part Number Example

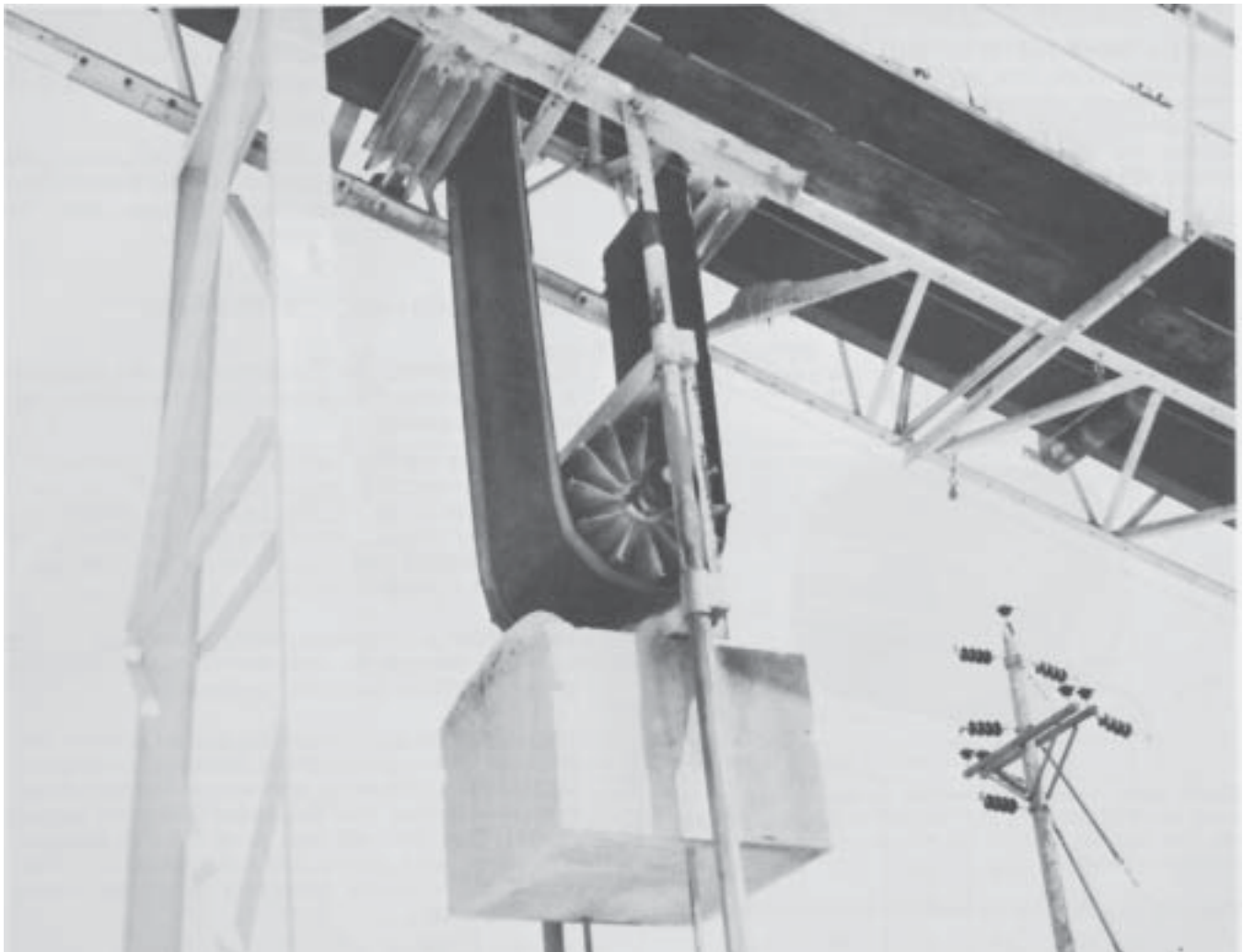
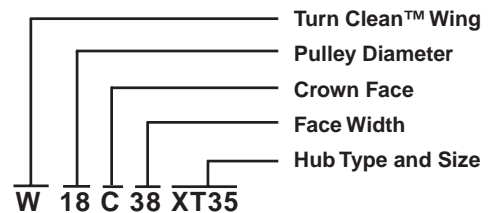

Wing pulleys, in general, are designed to be used in the dirtiest and most abrasive part of the conveyor system. Their self cleaning action is required to reduce material build up between the pulley and the belt which can cause belt misalignment and belt wear. When these conditions become so abusive that they actually reduce the life of a conventional wing pulley, an XT-reme™ solution to the problem is required.



VAN GORP® XT-reme™ wings have heavier contact bars, heavier wings and have reinforcing rings on all sizes. It also features the XT® system which is the premier hub and bushing system for conveyor pulleys.

The XT-reme™ wing is available in diameters ranging from 12 to 36 and face widths 12 to 76. It is also available with new VAN GORP® ♦DB♦ replaceable wing lagging for even more wing pulley life.

Part Number Example

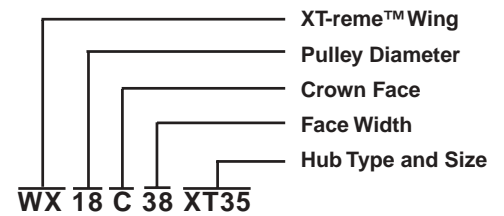

Features and Benefits

- Heavier contact bar for added wear in abrasive applications.
- Heavier wing for a greater load carrying service factor.
- Reinforcing rings to minimize the bending of the wing tips.
- XT® Hub and bushings with superior torque and thrust ratings.



LIGHTWEIGHT SLAT

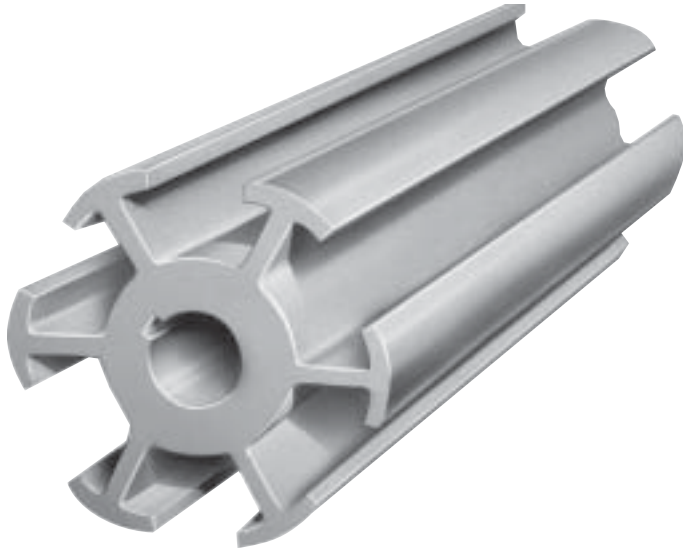

Occasionally the need arises for small diameter slat type pulleys which are used in small unloading and loading conveyors. VAN GORP has designed a light weight slat pulley in 4" - 5 1/8" - 6" diameters. Since the diameter is so small, it is impossible to use gussets in this pulley, but the individual slat wing principle is applied. If an excessive amount of moist, sticky material such as clay or bulk fertilizer falls on the pulley and belt, it is possible to stop the conveyor and then clean the material out of the wing openings. This pulley is offered with solid bore hubs in the 4", 5 1/8" and 6" diameters and a XT15 hub in the 6" diameter. Solid bores have one key-way and two set screws in each hub.

Extra Heavy Duty Wing Pulleys

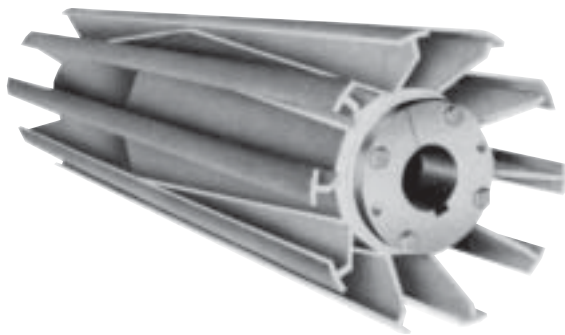

Available on XT®,  
Tapered Bore or  
Q-D® Hubs. See  
Page 32 for  
Bushing  
Locations

**RUGGED FOR LONG LIFE** — Built for the stress and strain of big loads...or unusually long, large conveyor systems. Designed after the SNAP-BACK® and TURN CLEAN™ wing pulleys. All welded steel construction. Outer bars have a long radius surface for maximum traction and minimum belt wear. All pulleys are jig welded, and accurate concentricity is assured because the contact bar is hydraulically pressed against the exterior wing edge and then welded together. Individual gussets are welded continuously to each wing and the hub forming a strong double-cone design.

**SPIRAL WING**



Available on XT®,  
Tapered Bore or  
Q-D® Hubs. See  
Page 32 for  
Bushing  
Locations

The spiral wing pulley is formed by a pair of flat steel bars helically wound towards one another with intervals between the convolutions of each. Individual gussets are welded continuously to each wing and the hub forming a strong double-cone design.

Rotation of the pulley automatically starts the self-cleaning action, discharging foreign material to the side of the conveyor.

No more belt misalignment because the multi-wing construction decreases the possibility of any material build up between the belt and pulley.

AVAILABLE IN CROWN OR STRAIGHT FACE.

SIZES: 10" THRU 36" Diameters and 12" THRU 76" Face.

NOTE: The finished diameter will be greater than the specified diameter by twice the spiral bar thickness.

Example: A 12" diameter spiral wing will actually be 12 3/4" over the spiral.

**SPIRAL DRUM**



The VAN GORP® Spiral Drum Pulley is formed by a pair of vertical steel bars helically wound around a heavy-duty reinforced drum pulley (H•D•R®) and towards one another with intervals between the convolutions of each. This unique design reduces the possibility of material build-up between the belt and the pulley in applications where self-cleaning wing type pulleys cannot be used.

Rotation of the pulley automatically starts the cleaning action, discharging foreign material to the side of the conveyor.

All pulleys are made with XT®, Tapered Bore or Q-D® Hubs, which permit the simplest, surest and most modern installation. Hubs are inset from the pulley end, and this inset permits the bushing to be easily removed in small confined spaces.

AVAILABLE IN CROWN OR STRAIGHT FACE.

SIZES: 12" THRU 44" DIAMETERS up to 144" face width.

See Page 13 for Bushing Location Dimensions.



◆DB◆ Wing Lagging has been designed to fit the standard Turn Clean™, XT-reme™ and Heavy Duty wing type pulleys. Tough 65 durometer - SBR (styrene butadiene) rubber hot vulcanized to a formed heavy gauge metal channel makes ◆DB◆ ready to extend the life of a Turn Clean™ wing pulley in even the most abrasive applications. ◆DB◆ will not only supply added life to your pulleys, it will reduce belt wear and can be simply and economically replaced in the field.

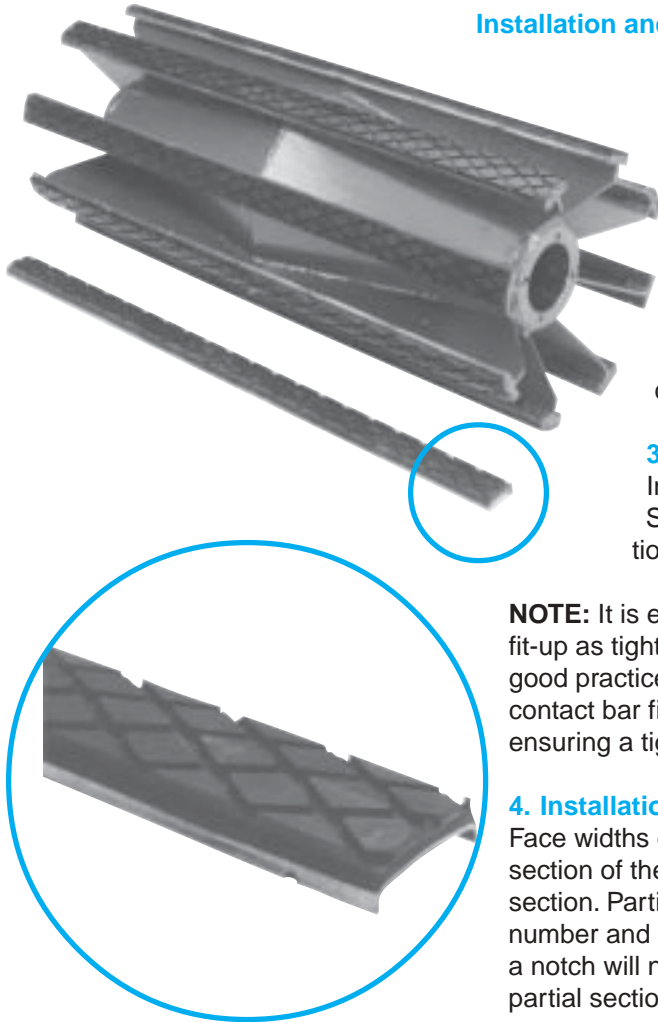

### Installation and Replacement Procedures

#### 1. Remove the Worn Rubber Lagging

All tac welds between the replaceable lagging and the contact bar are broken using a hand chisel or hand grinder.

#### 2. Clean Remaining Weld from Sides of Contact Bar

Using a hand grinder or chisel, clean all remaining weld from the sides of the existing contact bar. Remove any rust, dirt, or scale buildup from the sides and top of the contact bar.

#### 3. Install new Replaceable ◆DB◆ Lagging Insert

Install replacement ◆DB◆ lagging section to contact bar. Starting at end of contact bar tac weld per welding instructions at slotted areas.

**NOTE:** It is extremely important that the contact bar to lagging section fit-up as tight as possible to eliminate added stress to the tac welds. A good practice to follow is to tac weld the replaceable lagging to the contact bar first on the side towards the direction of rotation, thus ensuring a tight fit in the high stressed area.

#### 4. Installation when Face Width is Greater than 32.00".

Face widths greater than 32.00" will require the addition of a partial section of the replaceable lagging to be "butted" up against the 32.00" section. Partial Sections less than 6.00" should be discarded. Since the number and location of the notches in the replacement channel varies, a notch will need to be cut in the channel, 1.00" in from the end of the partial section.

### Welding Specifications for Replacement

Welding Wire: .09375" (3/32) Diameter  
 Type - ASWS E6011 (Lincoln - Fleetwood 180)  
 Amps: 85 Amps  
 Welder: AC or DC Welder



American Made

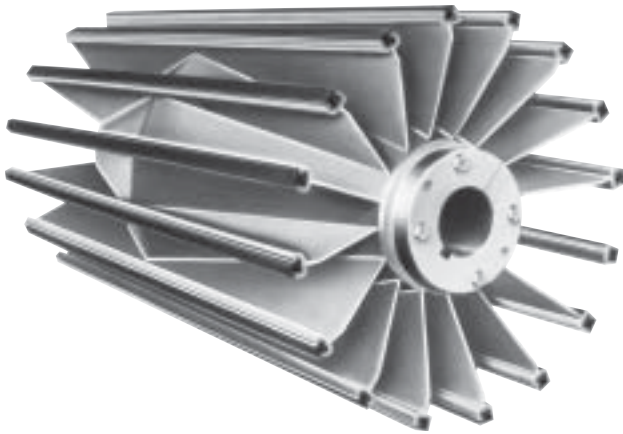

## SOLVE TOUGH MAINTENANCE PROBLEMS ECONOMICALLY

Utilizing the same basic frame as the Turn Clean™ the patented VAN GORP® SNAP-BACK® Pulley eliminates virtually every maintenance problem on conveyor systems handling wet, sticky or abrasive materials. Its exclusive design allows the pulley to automatically clean itself by reducing build-up, belt wear and eventually maintenance and downtime problems. Here's how it works:

High tensile strength rubber or Urethane lagging, encased in a steel jacket, displaces upon belt contact. When belt contact is broken, the rubber actually "snaps back" to its original height. Ideal in snub and bend applications where the pulley comes into contact with the belt's carrying side.

This unique feature assures minimum belt wear and maximum cleaning efficiency for years of maintenance-free service. Lagging can be easily and economically changed in the field by merely installing a new channeled rubber insert within the heavy-duty, 7-gauge steel jacket channel.

### Part Number Example

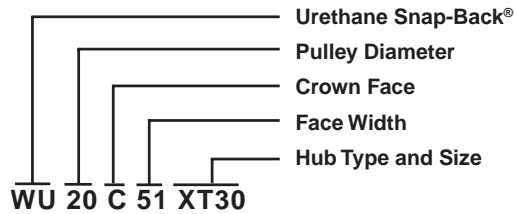
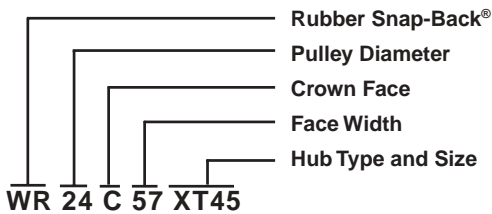

Custom Designed

VAN GORP continues to lead the conveyor pulley industry, not only due to high standards in manufacturing, but also because of its ongoing research and testing programs. We have provided customers with custom designed pulleys for their specific applications, such as wing pulleys with 11" shafts; 8 foot diameter drums; 16½ foot long stub shaft tubes; pulleys with V-grooves in the middle; and special deflection wheels.

**Pulleys  
Designed for the  
Deflection of corrugated side wall belting  
on "L" and "S" shape conveyors**



11 foot diameter deflection wheels used in a coal mine.

Deflection wheels under the city of Chicago used to excavate storm sewers.



Special attachments and modifications are a common request for conveyor pulley assemblies. Drilling and tapping for stub shafts, special key ways, speed indicator targets, are good examples. Contact VAN GORP for your special design needs.

Shaft drilled and tapped with a stub shaft for a speed sensor.

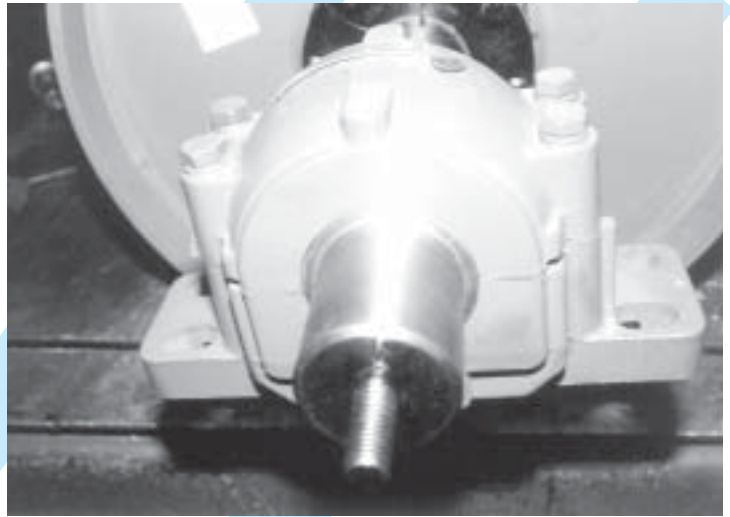

Drive pulley with a sprocket bolted to the end disc.

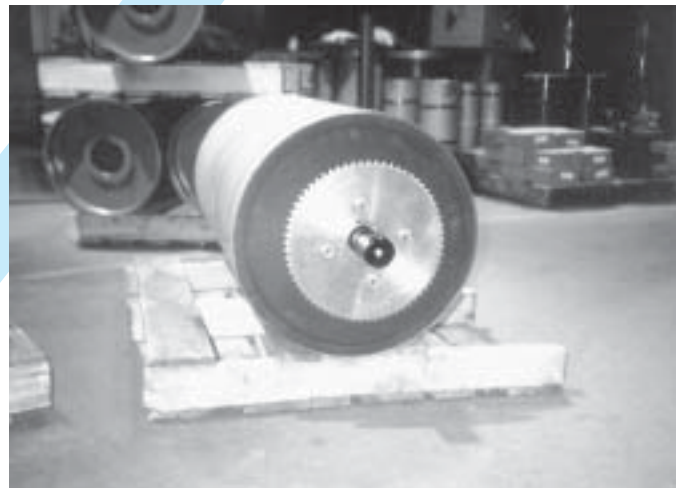

Roller assembly with a special milled slot for mounting.

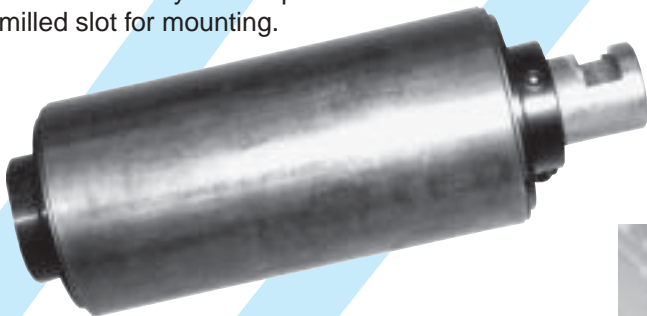

Drum pulley with speed indicator targets welded to the end discs.

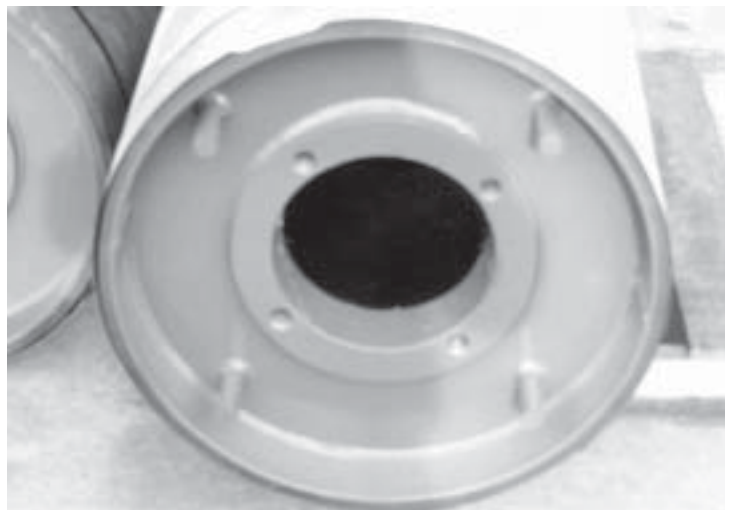



VAN GORP'S STANDARD SHAFTING IS AISI 1045, WHICH REPRESENTS THE HIGHER CARBON RANGE IN THE OPEN HEARTH CARBON GROUP. ITS MECHANICAL PROPERTY ADVANTAGES OVER LOWER CARBON STEELS PROVE ESPECIALLY VALUABLE FOR TRANSMISSION SHAFTING. THE HIGHER CARBON CONTENT IN AISI 1045 RESULTS IN ONE OF THE STRONGEST STEELS IN THE CARBON RANGE, EXCLUDING ALLOY STEELS, AND MACHINES TO A SMOOTHER FINISH THAN AISI 1018.

SHAFT DEFLECTION SHOULD BE CLARIFIED BECAUSE MANY CUSTOMERS ASSUME THAT AN ALLOY STEEL WILL HAVE LESS DEFLECTION THAN A LOW OR MEDIUM CARBON STEEL. THIS ASSUMPTION IS NOT CORRECT. THE PRINCIPAL OF SHAFT DEFLECTION IS QUOTED FROM THE PUBLICATION OF DELAVAL STEAM TURBINE COMPANY IN TRENTON, NEW JERSEY, ENTITLED "USEFUL DATA FOR DETERMINING STRESSES, TORQUES, BENDING MOMENTS AND DEFLECTIONS IN STEEL SHAFTS", AS FOLLOWS:

"Where an untreated carbon steel shaft is not strong enough, considerable improvement can be obtained by heat treatment and much more by the use of heat treated alloy steels, but if greater stiffness or rigidity is required, no improvement results from heat treatment or the use of better materials as deflection is entirely unrelated to strength.

"Unless the length or span is reduced, the only way that the deflection can be reduced is by INCREASING the size of the shaft as the modulus of elasticity of all steel is practically the same.

"In many cases when a shaft is made large enough to secure the required rigidity, the stress may be low enough that low strength steel may be entirely satisfactory unless greater hardness is required for other reasons."

**PLEASE REMEMBER, EXCESSIVE SHAFT DEFLECTION IS THE MAJOR CAUSE OF CONVEYOR PULLEY FAILURES. IT IS WISE TO BE GENEROUS IN SELECTING THE PROPER SHAFT DIAMETER FOR YOUR PARTICULAR SHAFT AND PULLEY APPLICATION.**

When ordering shafting, specify the following:

1. Diameter and length
2. Number and size of keyways required
3. Length of shaft which extends beyond each end of the pulley

4. Diameter and length of journal, if required
5. Bearing Centers

If possible, furnish a simple sketch of the pulley and shaft, as this will help eliminate errors.

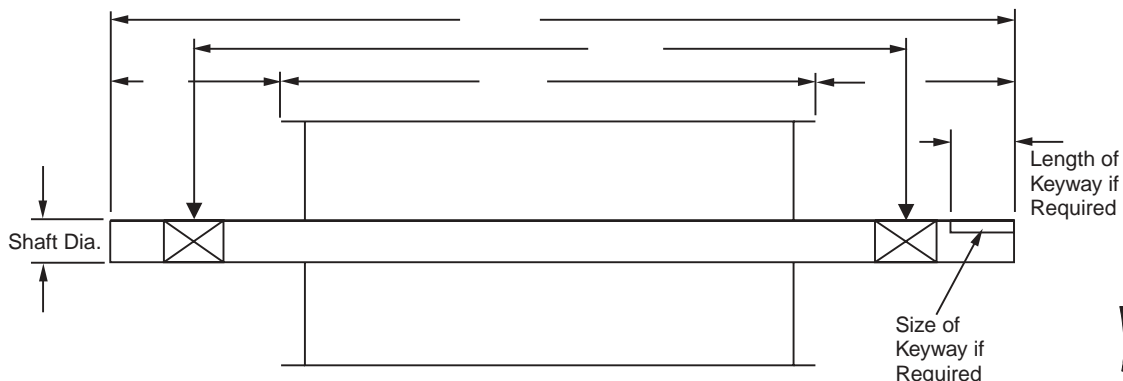

American Made

**SPECIAL WING PULLEYS**  
 Engineered For Special Applications

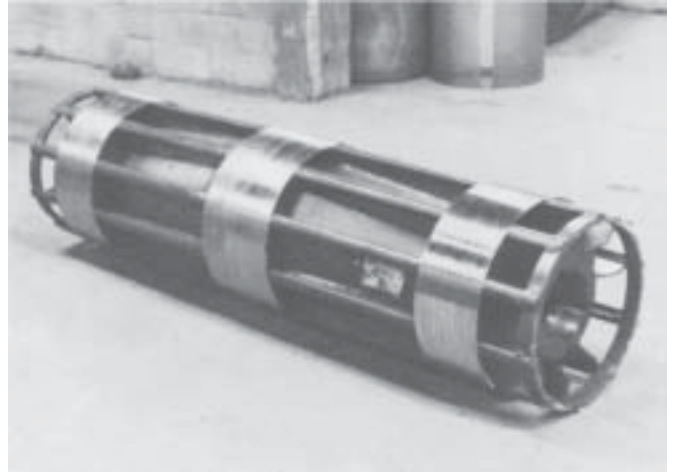
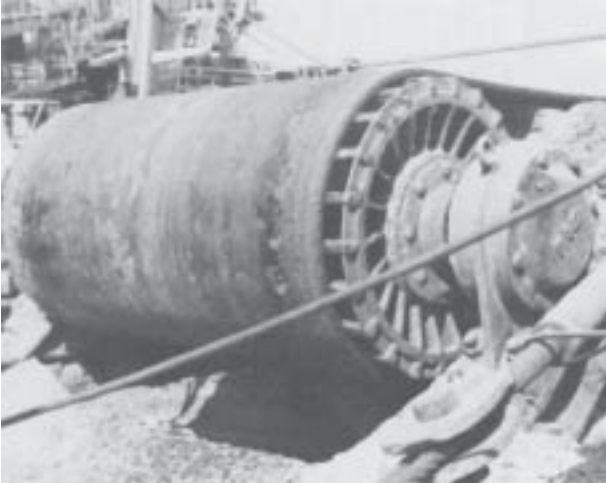

This is a very unique wing pulley application. A conventional drum pulley was used in the original installation and it was a constant problem; build-up would cause belt misalignment. The drum pulley was replaced with a special engineered wing pulley and the build-up problem was solved.

**SPECIAL TAIL PULLEY**  
 16" Dia. x 61½" Face

**CONVEYOR PULLEY ASSEMBLIES**

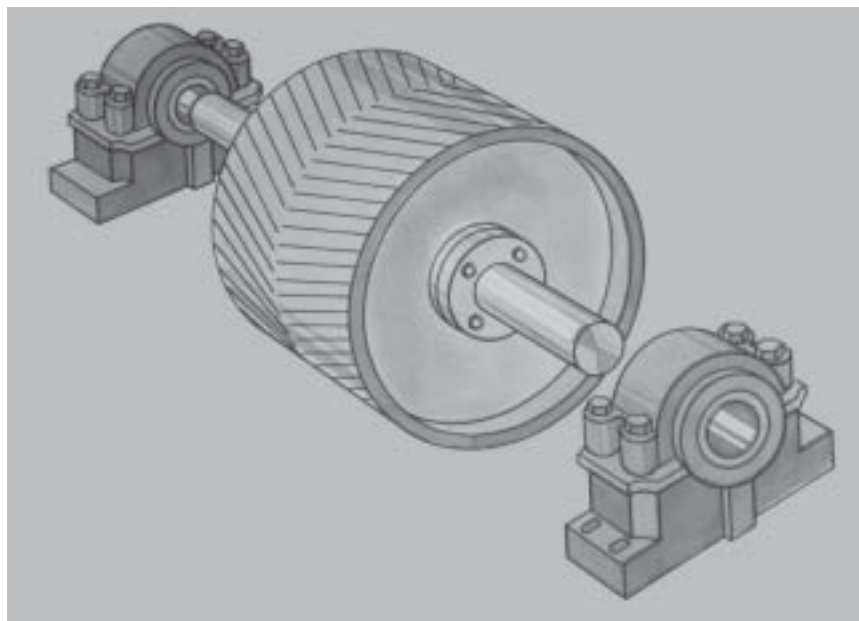

Pulley, Lagging, Shaft and Bearing Assemblies are available on application. Whatever your pulley requirements, let VAN GORP Engineers assist you in determining the proper pulley, lagging, bearing type and related components you need for maximum efficiency of operation.