



Please call Goodyear Rubber Products to order any products shown in this catalog  
1-727-822-4672 or 1-800-367-4673 toll free in the USA  
Email inquiries to: [Sales@GoodyearRubberProducts.com](mailto:Sales@GoodyearRubberProducts.com)



## contents

Galvanized Fittings		Stainless Steel Fittings	
hose sets	1 & 3	weld-ons	27
double hose connections	1 & 3	hose sets	29
threaded npt	5 & 9	flanges	31
flanges	7 & 9	threaded npt	31
elbows	11	elbows	32
increasers	13	increasers	32
reducers	13	reducers	32
s-bends	13		
t's	15	Pipe & HDPE	
y's	15	galvanized pipe	33
end plugs	17	aluminum pipe	34
end caps	17	fused high pressure hdpe fittings	35
double males	17	press-in low pressure hdpe fittings	36
double females	17		
Carbon Steel Weld-Ons		Specialty	
sets	19 & 21	clamps	37
Cast Aluminum Fittings		locking pins	37
weld-ons	23	valves	38
hose sets	24	cam-lock adapters	39
flanges	25	victaulic adapters	40
threaded npt	25	ring-lock adapters	40
elbows	26	ban-lock adapters	40
increasers	26	wellpoint equipment	41
reducers	26	strainer baskets	43
		custom fabrication	44



## Key Features and Benefits of the Wil-loc Coupling

- Quick pump connections decrease man-hours for pump installation/dismantling
- Ball and Socket design securely seated by O-Ring for vacuum-tight seal
- Durable construction provides years of use and decreases replacement costs
- Lever locking jaw can be secured with locking pin to prevent accidental or deliberate uncoupling
- Up to 30° coupling articulation allows for misaligned connections



**1** Debris from suction intake can damage pump impeller - Round or square hole strainer baskets decrease pump maintenance costs

**2** Strainer baskets take abuse in most applications - Wil-loc threaded strainer baskets can be replaced without replacing the ball assembly

**3** Kinked hoses create friction loss and decrease pump performance - Elbows minimize friction loss with smooth transitions

**4** Long suction runs benefit from full vacuum-rated pipe - Wil-loc pipe is more cost effective and easier to move than multiple suction hoses

**5** Rough terrain makes suction line installation difficult - PVC or rubber hose lays over and around obstructions, reducing set-up time

**6** Self Priming and Auto Priming volutes rely on air-tight connections - Wil-loc couplers are vacuum-tested to reduce priming time

**7** Pump failures cause major disruption - Flanged or threaded pump connections with Wil-loc couplers allow for fast pump replacement

**8** Kinked discharge hoses increase Total Dynamic Head (TDH) - Step Bows allow for smooth flow from volute to discharge point

**9** Accidental or deliberate uncoupling of by-pass systems cause costly spillages - Wil-loc Couplers have secure locking pins

**10** Open discharge can cause erosion and lead to property damage and fines - Pipe can be used in most situations to minimize erosion

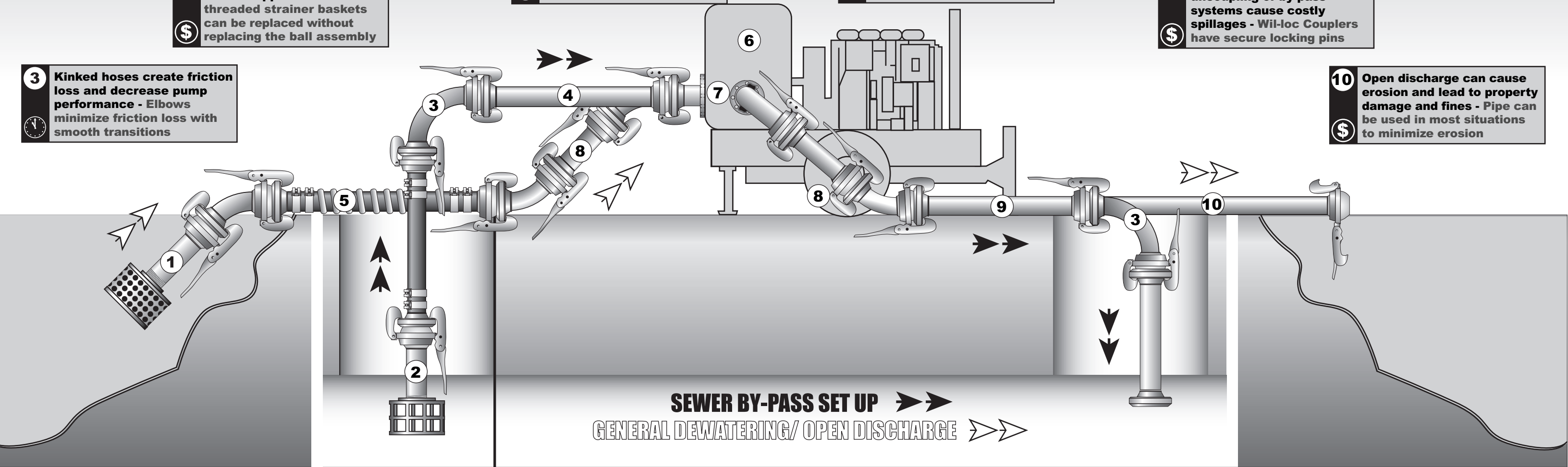

### Wil-loc B-Style Assembly

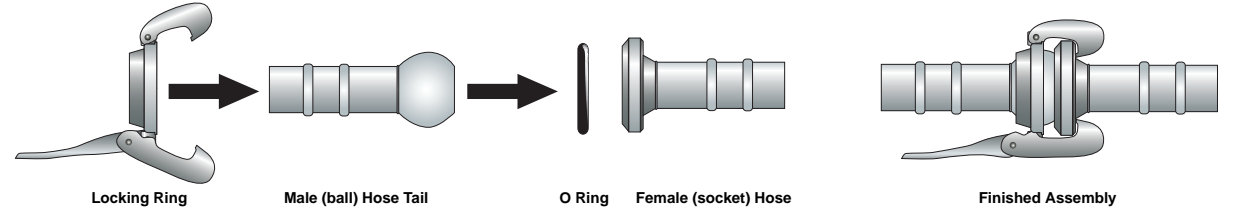

### Wil-loc A-Style Assembly

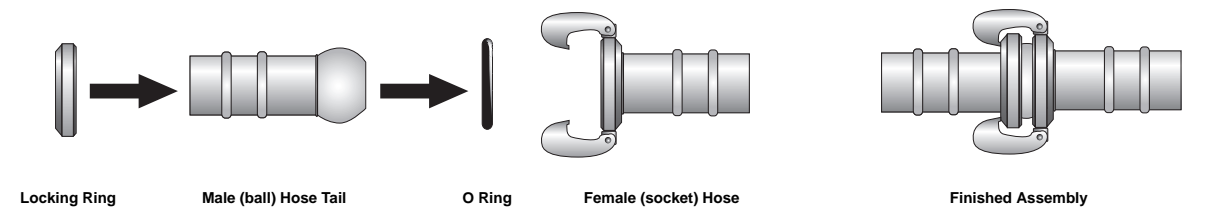



complete hose sets	part number	weight (lbs.)	list price
2" Hose Set Assembly	275 HSA2	2.60	38.05
3" Hose Set Assembly	275 HSA3	5.30	59.40
4" Hose Set Assembly	275 HSA4	11.70	106.25
5" Hose Set Assembly	275 HSA5	16.50	145.90
6" Hose Set Assembly	275 HSA6	21.70	189.40
8" Hose Set Assembly	275 HSA8	35.70	369.75



male hose ends	part number	weight (lbs.)	list price
2" Hose Tail Ball/Male	260 HTM2	.75	11.13
3" Hose Tail Ball/Male	260 HTM3	1.45	16.94
4" Hose Tail Ball/Male	260 HTM4	3.75	32.85
5" Hose Tail Ball/Male	260 HTM5	4.70	40.86
6" Hose Tail Ball/Male	260 HTM6	5.85	51.99
8" Hose Tail Ball/Male	260 HTM8	10.70	110.89



female hose ends	part number	weight (lbs.)	list price
2" Hose Tail Socket/Female	270 HTF2	.75	11.19
3" Hose Tail Socket/Female	270 HTF3	1.50	16.75
4" Hose Tail Socket/Female	270 HTF4	3.50	31.87
5" Hose Tail Socket/Female	270 HTF5	5.35	32.66
6" Hose Tail Socket/Female	270 HTF6	6.60	56.77
8" Hose Tail Socket/Female	270 HTF8	12.00	120.80



galvanized locking levers	part number	weight (lbs.)	list price
2" Lever Locking Ring	273 LR2	1.05	15.72
3" Lever Locking Ring	273 LR3	2.35	25.69
4" Lever Locking Ring	273 LR4	4.45	41.53
5" Lever Locking Ring	273 LR5	6.40	59.88
6" Lever Locking Ring	273 LR6	9.25	80.68
8" Lever Locking Ring	273 LR8	13.00	138.05



o-rings	part number	weight (lbs.)	list price
2" O-Ring	280 OR2	0.05	.80
3" O-Ring	280 OR3	0.10	1.55
4" O-Ring	280 OR4	0.20	2.70
5" O-Ring	280 OR5	0.40	5.50
6" O-Ring	280 OR6	0.50	6.00
8" O-Ring	280 OR8	0.55	11.00



double hose connections	part number	weight (lbs.)	list price
2" Double Hose Connection	278 DHC2	1.00	12.78
3" Double Hose Connection	278 DHC3	1.15	19.33
4" Double Hose Connection	278 DHC4	4.10	33.83
6" Double Hose Connection	278 DHC6	7.10	54.32
8" Double Hose Connection	278 DHC8	11.85	105.57

Wil-loc Male B-Style Hose Tails

vacuum rating	30 inches hg	number of ribs	2 & 3 inch = 2
psi rating	2 & 3 inch = 290		4 - 8 inch = 3
	4 - 8 inch = 175		

lever mechanical specs.	A	B	C	D	E
2" 50x50mm	7.09	3.35	4.92	3.94	2.44
3" 76x76mm	9.25	3.54	7.09	5.31	3.43
4" 108x100mm	10.83	6.69	9.25	7.48	5.20
5" 133x125mm	11.41	5.51	10.83	8.07	5.91
6" 159x150mm	13.39	6.30	11.81	9.06	6.69
8" 194x200mm	13.19	9.06	13.98	10.04	8.66

Hose Set Specifications to 1/100th of an inch • Specifications Subject to Change

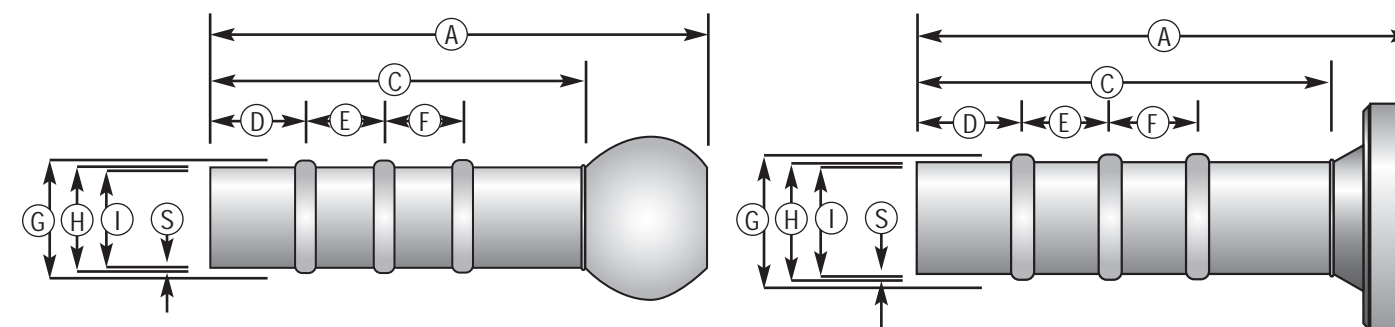
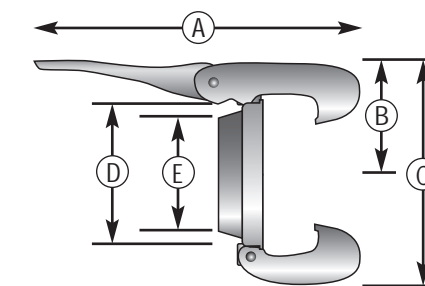

male mechanical specs.	A	C	D	E	F	G	H	I	S
2" 50x50mm	6.50	4.33	0.98	1.38		2.09	1.97	1.85	0.06
3" 76x76mm	8.07	5.31	1.38	1.38		3.11	2.99	2.87	0.06
4" 108x100mm	11.42	7.28	1.38	1.77	1.77	4.09	3.94	3.80	0.07
5" 133x125mm	11.61	7.87	1.38	1.77	1.77	5.08	4.92	4.78	0.07
6" 159x150mm	12.40	8.46	1.57	1.97	1.97	6.06	5.91	5.77	0.07
8" 194x200mm	14.96	9.84	1.97	2.36	2.36	8.11	7.87	7.71	0.08

Hose Set Specifications to 1/100th of an inch • Specifications Subject to Change

female mechanical specs.	A	C	D	E	F	G	H	I	S
2" 50x50mm	5.51	4.33	0.98	1.38		2.09	1.97	1.85	0.06
3" 76x76mm	6.69	5.31	1.38	1.38		3.11	2.99	2.87	0.06
4" 108x100mm	9.45	7.28	1.38	1.77	1.77	4.09	3.94	3.80	0.07
5" 133x125mm	10.04	7.87	1.38	1.77	1.77	5.08	4.92	4.78	0.07
6" 159x150mm	10.43	8.46	1.57	1.97	1.97	6.06	5.91	5.77	0.07
8" 194x200mm	12.99	9.84	1.97	2.36	2.36	8.11	7.87	7.71	0.08

Hose Set Specifications to 1/100th of an inch • Specifications Subject to Change

Tech Tip

Wil-loc Couplings have a higher working pressure rating than typical Cam-lock or other quick action couplings. Typical Cam-lock: 2" = 250psi, 3" = 125psi, 4" = 100psi, 5" = 75psi and 6" = 75 psi. Check with your manufacturer for specific ratings.



10" hose set shown.

complete hose sets	part number	weight (lbs.)	list price
10" Hose Set Assembly	276 HSA10	55.04	434.35
12" Hose Set Assembly*	276 HSA12	89.60	721.80
* 12" Hose Set Assembly comes with a locking bar			

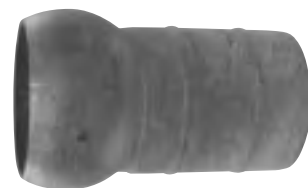

male hose tails	part number	weight (lbs.)	list price
10" Hose Tail Ball / Male	261 HTM10	28.06	220.01
12" Hose Tail Ball / Male	261 HTM12	43.55	337.09
all 10 and 12 inch a-style hose sets come with a locking ring			



10" female shown.

female hose tails	part number	weight (lbs.)	list price
10" Hose Tail Socket	271 HTF10	25.25	214.33
12" Hose Tail Socket*	271 HTF12	44.50	384.74
* 12" Hose Set Assembly comes with a locking bar			



galvanized locking rings	part number	weight (lbs.)	list price
10" Locking Ring	251 G10R	8.15	54.25
12" Locking Ring	251 G12R	14.15	94.14



o-rings	part number	weight (lbs.)	list price
10" O-ring	281 OR10	1.05	12.60
12" O-ring	281 OR12	1.55	14.50



double end connection	part number	weight (lbs.)	list price
10" Double Hose Connection	278 DHC10		CALL
12" Double Hose Connection	278 DHC12	25.70	230.84

Wil-loc A-Style Hose Tails

vacuum rating 30 inches hg  
 pressure rating 88 psi  
 number of ribs 2



A-Style Locking Ring

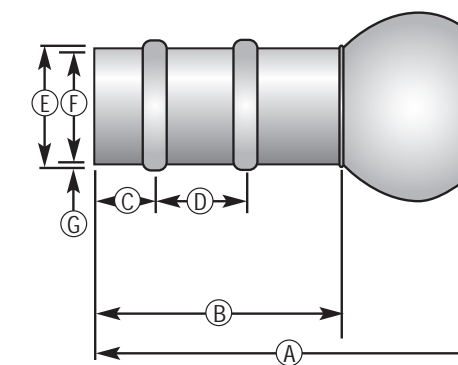

male mechanical specs.	A	B	C	D	E	F	G
10" 250mm x 150mm	18.54	11.81	3.54	4.72	10.08	9.84	0.98
12" 300mm x 300mm	18.54	11.81	3.54	4.72	12.05	11.81	0.98
Hose Set Specifications to 1/100th of an inch • Specifications Subject to Change							



12" Female Hose Tail



10" Female Hose Tail

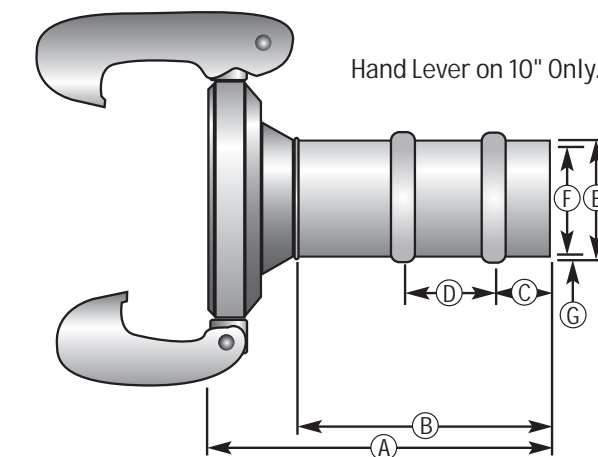

Hand Lever on 10" Only.

female mechanical specs.	A	B	C	D	E	F	G
10" 250mm x 150mm	16.14	11.81	3.54	4.72	10.08	9.84	0.98
12" 300mm x 300mm	16.89	11.81	3.54	4.72	12.05	11.81	0.98
Hose Set Specifications to 1/100th of an inch • Specifications Subject to Change							

Tech Tip

For easier coupling (especially of larger sizes) lubricate new Wil-loc O-rings. This will allow the ball to seat into the socket easier during first time usage.

Double hose connections provide a quick, inexpensive way to repair leaks in the field. Cut the leak area out of the lay-flat hose, insert the double hose connection and use two Wil-loc T-Bolt clamps per end to clamp the lay-flat onto double connection.



male threaded long balls	part number	weight (lbs.)	list price
2" Male Thrd/Long/Ball/Male	020 BMT2	3.10	40.55
3" Male Thrd/Long/Ball/Male	020 BMT3	6.10	62.25
4" Male Thrd/Long/Ball/Male	020 BMT4	10.60	109.80
6" Male Thrd/Long/Ball/Male	020 BMT6	21.15	202.86
8" Male Thrd/Long/Ball/Male	020 BMT8	37.60	388.19



male threaded short balls	part number	weight (lbs.)	list price
2" Male Thrd/Short/Ball/Male	022 BMT2	2.05	35.59
3" Male Thrd/Short/Ball/Male	022 BMT3	4.05	52.76
4" Male Thrd/Short/Ball/Male	022 BMT4	7.90	96.35
6" Male Thrd/Short/Ball/Male	022 BMT6	15.20	171.49
8" Male Thrd/Short/Ball/Male	022 BMT8	25.75	311.79



female threaded balls	part number	weight (lbs.)	list price
2" Female Thrd Ball/Male	025 BFTA2	3.05	49.95
3" Female Thrd Ball/Male	025 BFTA3	7.45	97.68
4" Female Thrd Ball/Male	025 BFTA4	12.50	143.31
6" Female Thrd Ball/Male	025 BFTA6	26.65	349.33
8" Female Thrd Ball/Male	025 BFTA8	49.70	599.24



male threaded sockets	part number	weight (lbs.)	list price
2" Male Thrd Socket/Female	040 SMT2	0.95	19.72
3" Male Thrd Socket/Female	040 SMT3	1.60	26.60
4" Male Thrd Socket/Female	040 SMT4	3.50	54.12
6" Male Thrd Socket/Female	040 SMT6	6.95	94.05
8" Male Thrd Socket/Female	040 SMT8	13.60	184.82



female threaded sockets	part number	weight (lbs.)	list price
2" Female Thrd Skt/Female	045 SFTA2	2.00	34.08
3" Female Thrd Skt/Female	045 SFTA3	4.95	71.52
4" Female Thrd Skt/Female	045 SFTA4	8.05	101.08
6" Female Thrd Skt/Female	045 SFTA6	18.15	271.89
8" Female Thrd Skt/Female	045 SFTA8	37.55	472.27

### Wil-loc NPT Threaded Fittings

vacuum rating 30 inches hg  
 pressure rating 2 - 3" = 290 psi, 4 - 8" = 175 psi

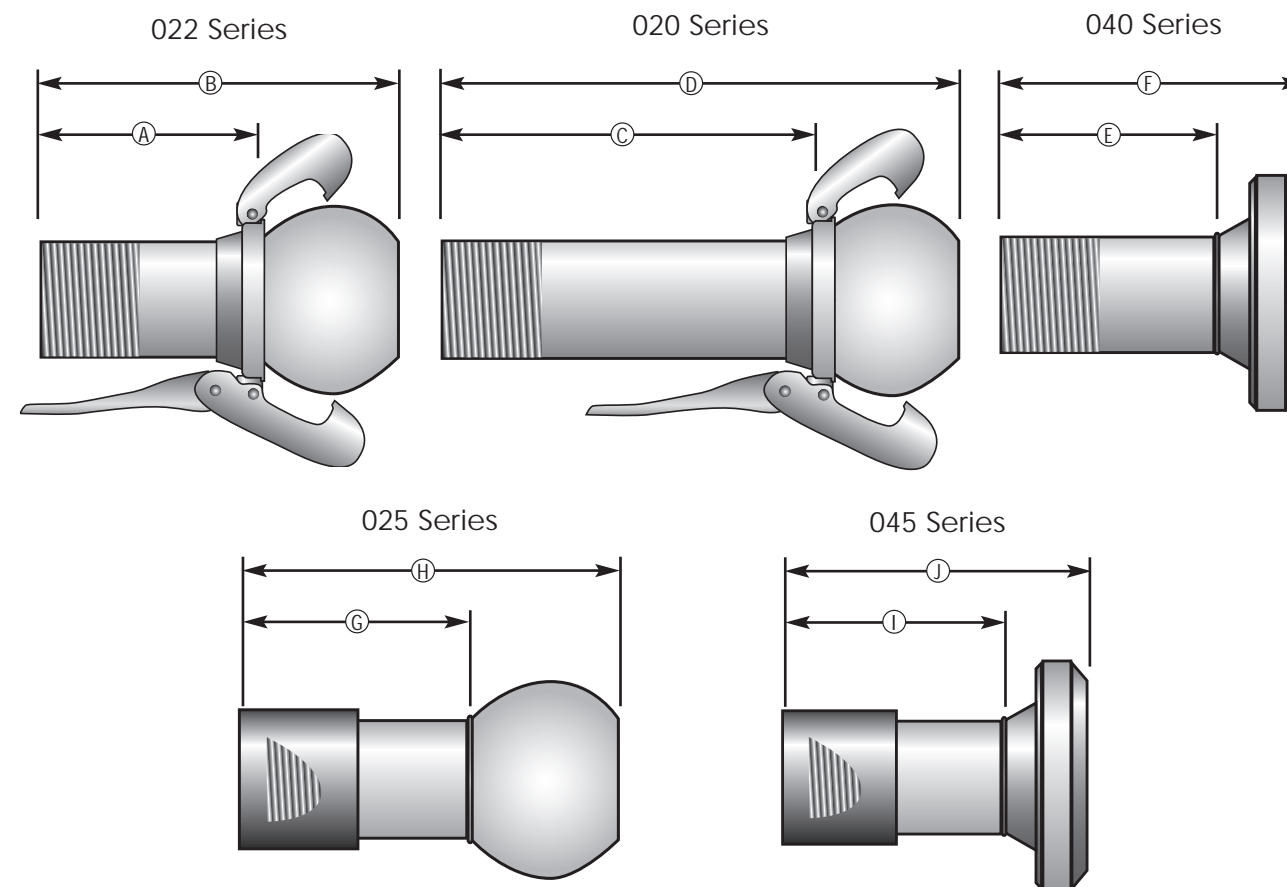

npt mechanical specs.	A	B	C	D	E	F	G	H	I	J
2" 50mm x 50mm	2.76	4.92	5.51	7.67	2.76	3.98	4.35	6.50	4.35	5.50
3" 76mm x 76mm	2.76	5.59	6.69	9.53	2.76	4.13	4.62	7.50	4.62	6.00
4" 108mm x 100mm	2.76	7.00	6.69	10.94	2.76	4.92	5.42	9.63	5.42	7.50
6" 159mm x 150mm	3.94	8.03	9.45	13.54	3.94	5.91	6.89	11.00	6.89	8.87
8" 194mm x 200mm	3.94	9.17	9.06	14.29	3.94	7.17	8.22	13.50	8.22	11.50

Specifications to 1/8th of an inch • Specifications Subject to Change

### Tech Tip

Wil-loc offers two different threaded shanks for the male connections. The 020 Series allows the locking ring lever to close above the male NPT threads. The 022 Series locking lever closes below the male NPT threads. Check application clearance before choosing the correct fit.

Before installing a Wil-loc Threaded Fitting, apply an all-purpose anti-seize product to threads. If the fitting should have to be removed from the pump, the anti-seize product can prevent seizure of the threads.



discharge flanges	part number	weight (lbs.)	list price
3" Flange Ball/Male Discharge	010 F3M	8.60	107.10
4" Flange Ball/Male Discharge	010 F4M	14.10	158.78
6" Flange Ball/Male Discharge	010 F6M	24.20	297.28
8" Flange Ball/Male Discharge	010 F8M	34.20	466.66

All flanges are designed to ASA 150 series hole specifications.



suction flanges	part number	weight (lbs.)	list price
3" Flange Socket/Fem Suction	030 F3F	5.50	83.57
4" Flange Socket/Fem Suction	030 F4F	8.95	110.42
6" Flange Socket/Fem Suction	030 F6F	13.20	206.77
8" Flange Socket/Fem Suction	030 F8F	20.90	313.71

All flanges are designed to ASA 150 series hole specifications.



neoprene gaskets	part number	weight (lbs.)	list price
3" Flange Gasket Neoprene	288 FGN3	0.20	5.00
4" Flange Gasket Neoprene	288 FGN4	0.30	8.00
6" Flange Gasket Neoprene	288 FGN6	0.35	12.00
8" Flange Gasket Neoprene	288 FGN8	0.35	16.50
10" Flange Gasket Neoprene	289 FGN10	0.50	21.60
12" Flange Gasket Neoprene	289 FGN12	0.65	30.00

1/4" thickness / full faced



increasing flanges	part number	weight (lbs.)	list price
4" Flange x 6" Male	033 F4-6M	14.00	269.67
6" Flange x 8" Male	033 F6-8M	49.75	408.81
4" Flange x 6" Female	032 F4-6F	24.75	144.95
6" Flange x 8" Female	032 F6-8F	19.00	213.07

All flanges are designed to ASA 150 series hole specifications.



reducing flanges	part number	weight (lbs.)	list price
6" Flange x 4" Male	033 F6-4M	21.25	239.77
8" Flange x 6" Male	033 F8-6M	41.75	362.91
6" Flange x 4" Female	032 F6-4F	12.00	148.07
8" Flange x 6" Female	032 F8-6F	20.00	215.55

All flanges are designed to ASA 150 series hole specifications.

### Wil-loc Flanges

vacuum 30 inches hg  
 flange pattern ASA 150  
 number of holes 3" has 4 bolt holes  
 4 - 8" has 8 bolt holes  
 pressure rating 3" = 290 psi, 4 - 8" = 175 psi

male flange specs.	A	B	C
3" Male Flange	10.00	6.50	2.88
4" Male Flange	11.88	7.00	3.50
6" Male Flange	13.63	9.00	4.00
8" Male Flange	15.63	9.88	5.25

Specifications to 1/8th of an inch & Subject to Change

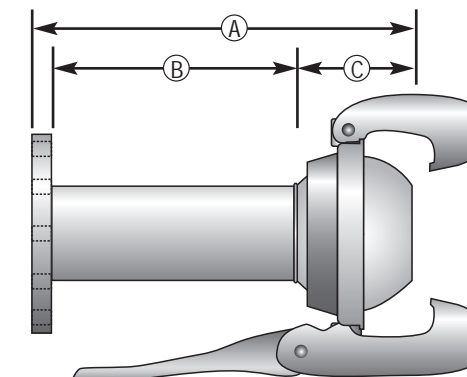

female flange specs.	A	B	C
3" Female Flange	4.63	2.75	1.38
4" Female Flange	6.50	4.00	2.25
6" Female Flange	6.50	4.00	2.25
8" Female Flange	7.75	4.00	3.25

Specifications to 1/8th of an inch & Subject to Change

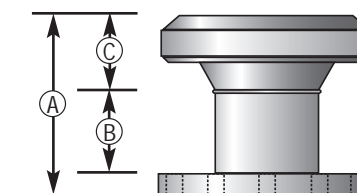

ASA flange specs.	A	B	C
3" ASA 150 Flange	7.50	6.00	0.75
4" ASA 150 Flange	9.00	7.50	0.75
6" ASA 150 Flange	11.00	9.50	0.875
8" ASA 150 Flange	13.50	11.95	0.875

Specifications to 1/8th of an inch & Subject to Change

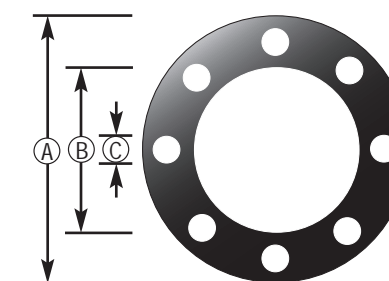

### Tech Tip

Wil-loc Flange Fittings are manufactured to ASA 150 pattern specifications. Gaskets should be used when mounting the flange fittings to a pump. If your pumps require other flange types or sizes, please contact your Wil-loc representative or dealer.

Wil-loc Increasing Flanges allow quick connection of high flow pumps to larger discharge lines. Higher flows can be achieved because larger diameter pipe decreases friction losses.



male pump flanges	part number	weight (lbs.)	list price
10" Flange Ball/Male Discharge	011 F10M	41.70	490.22
12" Flange Ball/Male Discharge	011 F12M	62.90	690.42
All flanges are designed to ASA hole specifications.			



female pump flanges	part number	weight (lbs.)	list price
10" Flange Socket/Fem Suction	031 F10F	42.00	475.65
12" Flange Socket/Fem Suction	031 F12F	73.45	787.29
All flanges are designed to ASA hole specifications.			



increasing & reducing balls	part number	weight (lbs.)	list price
10" Flange x 12" Male	034 F10-12M	90.00	547.62
12" Flange x 10" Male	034 F12-10M	54.75	522.67
All flanges are designed to ASA hole specifications.			

B-style coupling shown.



increasing & reducing sockets	part number	weight (lbs.)	list price
10" Flange x 12" Female	035 F10-12F	93.00	721.07
12" Flange x 10" Female	035 F12-10F	53.50	607.19
All flanges are designed to ASA hole specifications.			

B-style coupling shown.



threaded discharge balls	part number	weight (lbs.)	list price
10" Male Threaded Ball/Male	021 BMT10	42.00	700.11
12" Male Threaded Ball/Male	021 BMT12	56.00	997.98
Threads are cut to NPT specifications.			

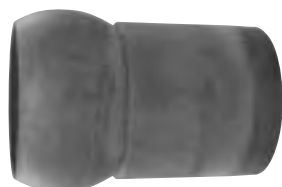

threaded suction sockets	part number	weight (lbs.)	list price
10" Male Thrd Skt/Female	041 SMT10	33.00	695.79
12" Male Thrd Skt/Female	041 SMT12	58.00	1036.23
Price includes Locking Ring.			

### Wil-loc Flanges

vacuum 30 inches hg  
 pressure rating 88 psi  
 flange pattern ASA 150  
 number of holes 12 bolt holes  
 thread pattern NPT  
 Hand lever on 10" only.

a-style flange specs.	A	B	C
10" Flange Balls	13.25	6.00	6.75
12" Flange Balls	15.00	6.00	8.38
10" Flange Sockets	10.88	6.90	4.38
12" Flange Sockets	21.75	16.00	5.75
Specifications to 1/8th of an inch & Subject to Change			

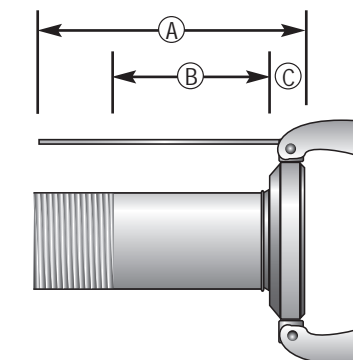
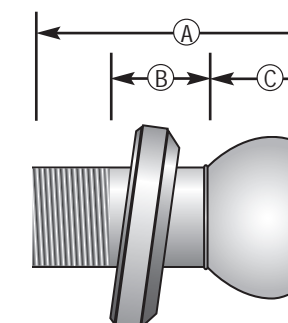
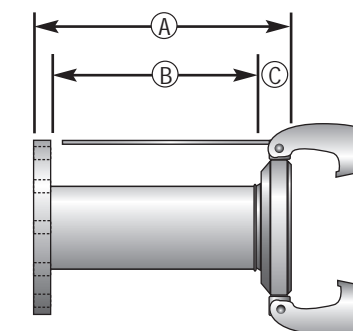
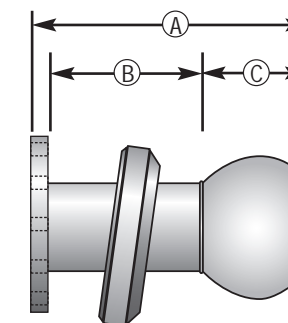

a-style NPT specs.	A	B	C
10" Threaded Balls	17.75	12.25	6.75
12" Threaded Balls	20.50	12.25	8.38
10" Threaded Sockets	15.75	12.00	4.37
12" Threaded Sockets	17.00	12.00	5.75
Specifications to 1/8th of an inch & Subject to Change			

### Tech Tip

The quick action and flexibility of 10" and 12" Wil-loc Couplings provides the end user with significant advantages over Victaulic or flanged methods previously used on large line applications.

Wil-loc full-face Neoprene Gaskets provide superior sealing and longevity compared to half-face flange gaskets.



45° a-style elbow

90° elbow	part number	weight (lbs.)	list price
2" 90 Degree Elbow	070 E2-90	3.05	50.34
3" 90 Degree Elbow	070 E3-90	5.35	69.75
4" 90 Degree Elbow	070 E4-90	11.00	115.67
6" 90 Degree Elbow	070 E6-90	21.00	219.35
8" 90 Degree Elbow	070 E8-90	33.00	394.31

60° elbow	part number	weight (lbs.)	list price
2" 60 Degree Elbow	075 E2-60	3.00	50.34
3" 60 Degree Elbow	075 E3-60	4.05	69.75
4" 60 Degree Elbow	075 E4-60	10.05	115.67
6" 60 Degree Elbow	075 E6-60	20.00	219.35
8" 60 Degree Elbow	075 E8-60	26.00	394.31

45° elbow	part number	weight (lbs.)	list price
2" 45 Degree Elbow	080 E2-45	2.05	47.16
3" 45 Degree Elbow	080 E3-45	4.00	65.22
4" 45 Degree Elbow	080 E4-45	11.00	107.26
6" 45 Degree Elbow	080 E6-45	19.05	197.71
8" 45 Degree Elbow	080 E8-45	29.75	345.51

30° elbow	part number	weight (lbs.)	list price
2" 30 Degree Elbow	085 E2-30	3.00	47.16
3" 30 Degree Elbow	085 E3-30	3.75	65.22
4" 30 Degree Elbow	085 E4-30	10.00	107.26
6" 30 Degree Elbow	085 E6-30	17.75	197.71
8" 30 Degree Elbow	085 E8-30	30.00	345.51

a-style 90° elbow	part number	weight (lbs.)	list price
10" 90 Degree Elbow	086 E10-90	50.00	456.00
12" 90 Degree Elbow*	086 E12-90	81.00	724.52

\*12" sockets come with a closing bar

a-style 45° elbow	part number	weight (lbs.)	list price
10" 45 Degree Elbow	086 E10-45	44.00	366.85
12" 45 Degree Elbow*	086 E12-45	71.75	621.17

\*12" sockets come with a closing bar

Wil-loc Elbows

vacuum 30 inches hg

pressure rating 2 - 3" = 290 psi  
 4 - 8" = 175 psi  
 10 - 12" = 88 psi

90° elbow specs.	A	B
2" 90 Degree Elbow	7.91	8.86
3" 90 Degree Elbow	9.33	10.75
4" 90 Degree Elbow	12.95	14.84
6" 90 Degree Elbow	18.58	20.59
8" 90 Degree Elbow	16.38	18.39
10" 90 Degree Elbow	17.72	20.12
12" 90 Degree Elbow	18.31	21.73

Specifications to 1/8th of an inch & Subject to Change

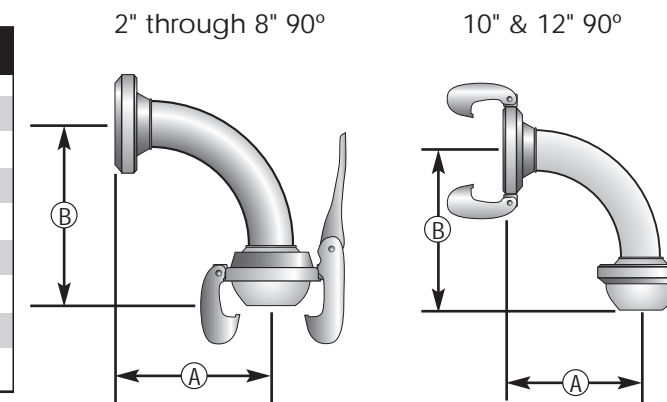

30°, 45° & 60° specs.	30°	45°	60°
2" Elbows	9.07	8.07	6.69
3" Elbows	11.02	9.84	8.27
4" Elbows	15.75	14.17	9.45
6" Elbows	20.47	17.72	14.37
8" Elbows	19.69	17.52	14.76
10" Elbows	22.64	20.47	17.72
12" Elbows	24.80	22.83	20.08

Specifications to 1/8th of an inch & Subject to Change

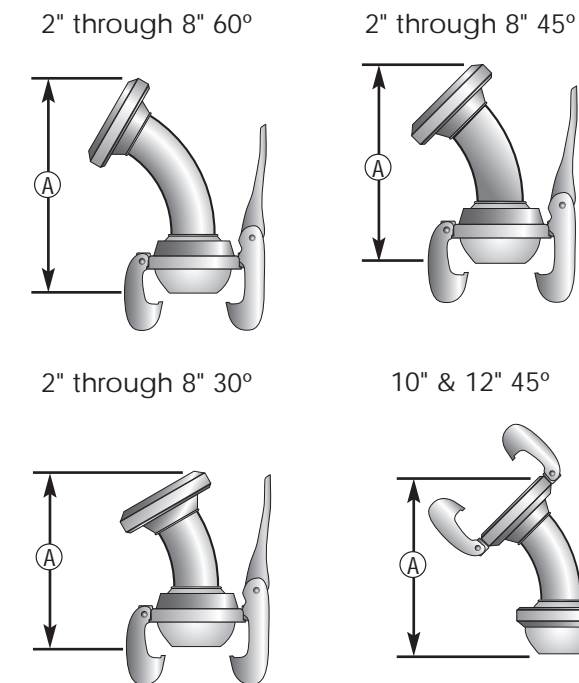

Tech Tip

When connecting ball and socket coupled hoses and fittings to a pump, position the locking jaws of the lever locking ring as close to 12 o'clock and 6 o'clock (in other words, top and bottom) as possible.

Wil-loc Elbows allow smooth transitions through bends and turns on suction or discharge lines. Using Wil-loc Elbows will reduce the wear of your hose and eliminate flow restrictions caused by kinking of lay-flat hose.



B-style coupling shown.

increasers	part number	weight (lbs.)	list price
2" x 3" Increaser	150 IN2-3M	4.50	62.43
2" x 4" Increaser	150 IN2-4M	6.85	126.68
3" x 4" Increaser	150 IN3-4M	7.75	129.73
3" x 6" Increaser	150 IN3-6M	14.05	200.83
4" x 6" Increaser	150 IN4-6M	15.00	168.84
4" x 8" Increaser	150 IN4-8M	21.75	328.33
6" x 8" Increaser	150 IN6-8M	24.40	298.96

a-style increasers	part number	weight (lbs.)	list price
8" x 10" Increaser	151 IN8-10M	50.00	366.02
8" x 12" Increaser*	151 IN8-12M	74.00	445.09
10" x 12" Increaser*	151 IN10-12M	98.50	565.93

\*12" sockets come with a closing bar

reducers	part number	weight (lbs.)	list price
3" x 2" Reducer	160 R3-2M	2.65	53.38
4" x 3" Reducer	160 R4-3M	5.65	123.03
6" x 2" Reducer	160 R6-2M	6.60	140.20
6" x 3" Reducer	160 R6-3M	7.35	152.83
6" x 4" Reducer	160 R6-4M	10.95	136.40
8" x 2" Reducer	160 R8-2M	9.40	215.04
8" x 3" Reducer	160 R8-3M	11.00	219.07
8" x 4" Reducer	160 R8-4M	15.65	246.24
8" x 6" Reducer	160 R8-6M	21.85	242.23

a-style reducers	part number	weight (lbs.)	list price
10" x 8" Reducer	161 R10-8M	71.30	375.96
12" x 8" Reducer*	161 R12-8M	102.50	652.00
12" x 10" Reducer*	161 R12-10M	160.00	580.06

\*12" sockets come with a closing bar

s-bends	part number	weight (lbs.)	list price
4" Modular S Bend	162 SBMA4	68.00	372.72
6" Modular S Bend	162 SBMA6	81.00	637.68
8" Modular S Bend	162 SBMA8	125.00	1,015.76



B-style coupling shown.

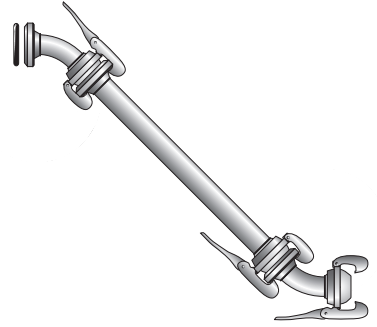

**Wil-loc Reducers & Increases**

vacuum 30 inches hg  
 pressure rating 2 - 3" = 290 psi  
 4 - 8" = 175 psi  
 10 - 12" = 88 psi

increaser specs.	A
2" x 3" Increaser	9.84
3" x 4" Increaser	11.42
4" x 6" Increaser	12.00
6" x 8" Increaser	16.34
8" x 10" Increaser	21.75
8" x 12" Increaser	23.50
10" x 12" Increaser	24.75

Specifications to 1/8th of an inch. Subject to change.

reducer specs.	A
3" x 2" Reducer	9.25
4" x 3" Reducer	11.23
6" x 2" Reducer	9.84
6" x 3" Reducer	11.02
6" x 4" Reducer	12.00
8" x 2" Reducer	13.00
8" x 3" Reducer	13.00
8" x 4" Reducer	17.32
8" x 6" Reducer	16.54
10" x 8" Reducer	22.50
12" x 8" Reducer	23.00
12" x 10" Reducer	24.00

Specifications to 1/8th of an inch. Subject to change.

reducer specs.	A
4" S - Bends	61.00
6" S - Bends	70.00
8" S - Bends	72.00

Specifications to 1/8th of an inch. Subject to change.

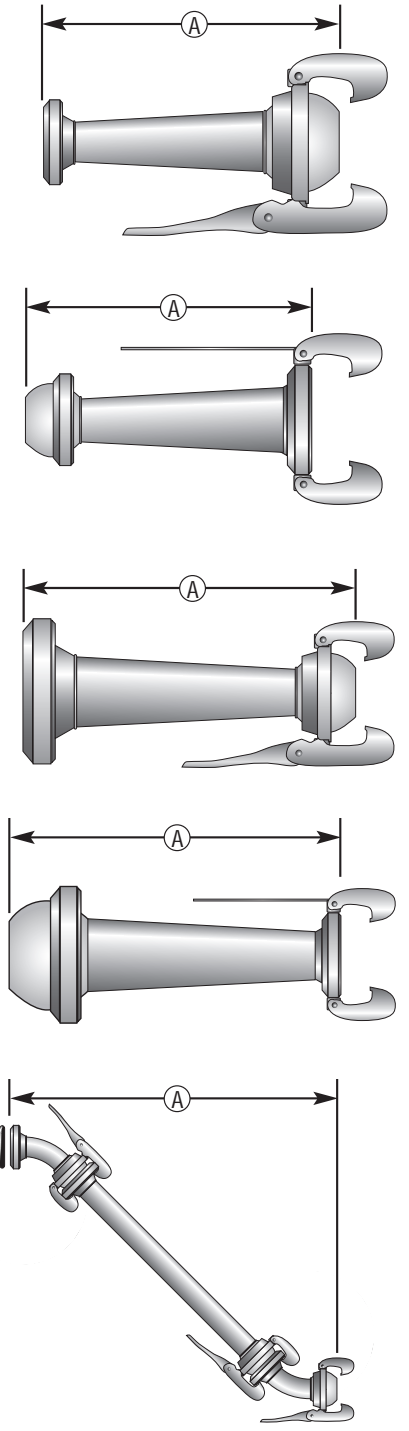

**Tech Tip**

Wil-loc Reducers and Increases are manufactured with a cone-shaped pipe, which allows for less flow restriction and smoother transition from one size to another.

Wil-loc modular S-Bends provide a smooth transition from a pump's discharge outlet to ground level. Combination of two 45-degree elbows & short pipe allows for maximum flexibility to accommodate unique jobsites and ground conditions.



T's with male connection	part number	weight (lbs.)	list price
2" Tee Standard / M. Conn.	060 T2M	5.00	98.21
3" Tee Standard / M. Conn.	060 T3M	6.00	146.13
4" Tee Standard / M. Conn.	060 T4M	22.00	234.05
6" Tee Standard / M. Conn.	060 T6M	35.00	415.14
8" Tee Standard / M. Conn.	060 T8M	62.00	687.26
10" Tee Standard / M. Conn.	061 T10M	100.00	655.08
12" Tee Standard / M. Conn.*	061 T12M	135.00	1,223.05

\*12" T's come with a closing bar.

T's with female connection	part number	weight (lbs.)	list price
2" T Socket Connection	050 T2F	4.00	80.54
3" T Socket Connection	050 T3F	7.00	115.26
4" T Socket Connection	050 T4F	14.00	189.72
6" T Socket Connection	050 T6F	31.00	334.67
8" T Socket Connection	050 T8F	48.00	558.36
10" T Socket Connection	054 T10F	75.00	655.14
12" T Socket Connection*	054 T12F	125.00	1,268.18

\*12" T's come with a closing bar.

inline T's w/ male connect	part number	weight (lbs.)	list price
2" Inline T/M. Connection	051 LT2M	4.00	80.54
3" Inline T/M. Connection	051 LT3M	7.00	115.26
4" Inline T/M. Connection	051 LT4M	14.00	189.72
6" Inline T/M. Connection	051 LT6M	30.00	334.67
8" Inline T/M. Connection	051 LT8M	43.00	558.36
10" Inline T/M. Connection	052 LT10M	75.00	655.14
12" Inline T/M. Connection*	052 LT12M	125.00	1,268.18

\*12" T's come with a closing bar.

double female Y's	part number	weight (lbs.)	list price
4" Y Double Female/Male	064 YM4	14.00	193.44
6" Y Double Female/Male	064 YM6	35.00	326.49
8" Y Double Female/Male	064 YM8	49.00	754.03
10" Y Double Female/Male	065 YM10	117.00	815.69
12" Y Double Female/Male*	065 YM12	204.00	1,387.44

\*12" Y sockets come with a closing bar.

increasing Y's	part number	weight (lbs.)	list price
2 - 4" x 6" Y Increaser Male	066 YI4-6	43.00	321.02
2 - 6" x 8" Y Increaser Male	066 YI6-8	66.00	408.09
2 - 8" x 10" Y Increaser Male	067 YI8-10	79.00	836.09
2 - 8" x 12" Y Increaser Male*	067 YI8-12	114.00	1,240.56
2 - 10" x 12" Y Increaser Male*	067 YI10-12	165.00	1,336.06

\*12" Y sockets come with a closing bar.

Wil-loc T's

vacuum 30 inches hg  
 pressure rating 2 - 3" = 290 psi  
 4 - 8" = 175 psi  
 10 - 12" = 88 psi

standard T specs.	A	B	C
2" T Standard Male	14.02	7.09	2.36
3" T Standard Male	16.14	9.25	2.76
4" T Standard Male	20.32	11.42	2.76
6" T Standard Male	22.63	12.00	3.15
8" T Standard Male	27.68	13.00	3.94
10" T Standard Male	33.50	17.75	6.00
12" T Standard Male	37.50	20.50	6.00

Specifications to 1/8th of an inch. Subject to change.

T socket specs.	A	B	C
2" T Socket	14.02	4.13	2.36
3" T Socket	16.14	4.53	2.76
4" T Socket	30.32	5.71	2.76
6" T Socket	22.63	7.09	3.15
8" T Socket	27.68	9.25	3.94
10" T Socket	33.25	15.50	6.00
12" T Socket	37.50	17.25	6.00

Specifications to 1/8th of an inch. Subject to change.

T male specs.	A	B	C
2" T Inline Male	13.03	7.09	2.36
3" T Inline Male	14.33	9.25	2.76
4" T Inline Male	13.78	11.42	2.76
6" T Inline Male	20.63	12.00	3.15
8" T Inline Male	25.67	13.00	3.94
10" T Inline Male	30.75	18.00	6.00
12" T Inline Male	34.25	20.50	6.00

Specifications to 1/8th of an inch. Subject to change.

2" through 8" Standard T

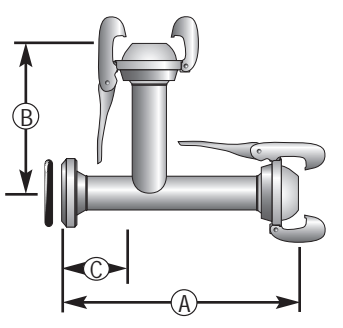

10" & 12" Standard T

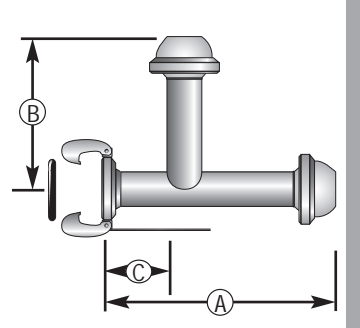

2" through 8" Female T

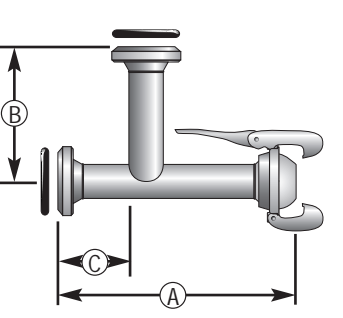

10" & 12" Female T

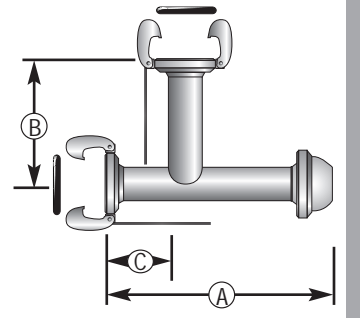

2" through 8" Inline T

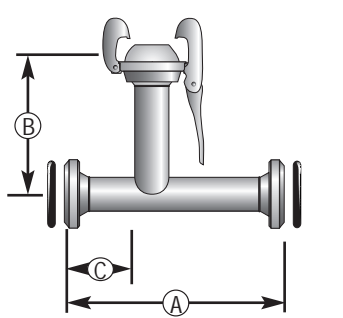

10" & 12" Inline T

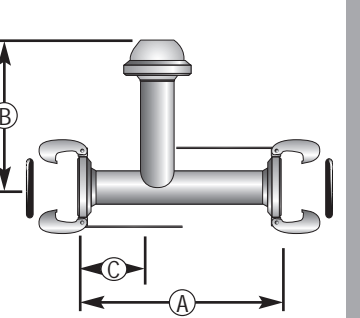

Tech Tip

When setting up a sewer by-pass pumping application, T or Y connections can be used to tie in a back-up pump's suction and discharge lines to the primary system.

Using two Wil-loc Flange Check Valve assemblies and one Y allows both the primary and the back-up pump in a by-pass application to be quickly and easily connected to a single discharge line.



end plugs	part number	weight (lbs.)	list price
2" End Plug Ball/Male	090 EP2	1.35	24.73
3" End Plug Ball/Male	090 EP3	2.35	39.62
4" End Plug Ball/Male	090 EP4	4.45	50.09
6" End Plug Ball/Male	090 EP6	8.90	88.60
8" End Plug Ball/Male	090 EP8	11.65	121.15



a-style end plugs	part number	weight (lbs.)	list price
10" End Plug Ball/Male	091 EP10	25.00	106.03
12" End Plug Ball/Male	091 EP12	44.00	253.95



end caps	part number	weight (lbs.)	list price
2" End Cap Socket/Female	100 EC2	0.40	8.37
3" End Cap Socket/Female	100 EC3	0.80	9.24
4" End Cap Socket/Female	100 EC4	1.95	19.10
6" End Cap Socket/Female	100 EC6	3.90	37.57
8" End Cap Socket/Female	100 EC8	7.80	75.51



a-style end caps	part number	weight (lbs.)	list price
10" End Cap Socket/Female	101 EC10	16.00	132.43
12" End Cap Socket/Female	101 EC12	36.00	264.94

\*12" end caps come with a closing bar



double balls	part number	weight (lbs.)	list price
2" Double Ball/Male	110 DB2	5.00	53.69
3" Double Ball/Male	110 DB3	6.80	85.43
4" Double Ball/Male	110 DB4	13.50	147.48
6" Double Ball/Male	110 DB6	26.45	265.04
8" Double Ball/Male	110 DB8	41.15	466.97
10" Double Ball/Male	111 DB10	54.00	354.08
12" Double Ball/Male	111 DB12	96.00	627.43

B-style double ball shown.



double sockets	part number	weight (lbs.)	list price
2" Double Socket/Female	120 DS2	0.90	19.46
3" Double Socket/Female	120 DS3	2.00	28.95
4" Double Socket/Female	120 DS4	4.50	54.68
6" Double Socket/Female	120 DS6	5.00	97.34
8" Double Socket/Female	120 DS8	13.65	186.62
10" Double Socket/Female	121 DS10	42.00	388.92
12" Double Socket/Female	121 DS12	87.00	750.99

\*12" end caps come with a closing bar

B-style double socket shown.

end plug specs.	A
2" End Plug Ball/Male	2.17
3" End Plug Ball/Male	2.87
4" End Plug Ball/Male	4.21
6" End Plug Ball/Male	4.06
8" End Plug Ball/Male	5.00
10" End Plug Ball/Male	6.73
12" End Plug Ball/Male	8.35

Specifications to 1/8th of an inch. Subject to change.

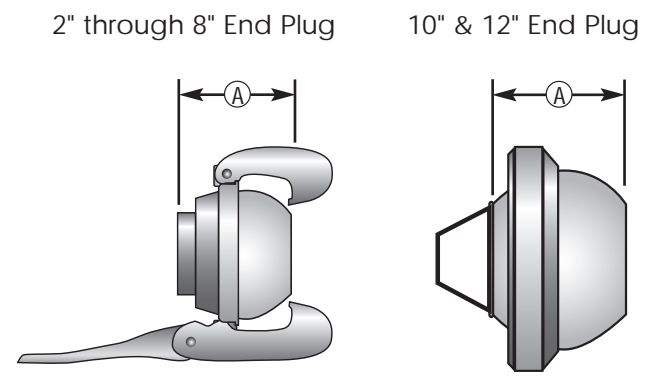

end cap specs.	A
2" End Cap Socket Female	3.27
3" End Cap Socket Female	4.57
4" End Cap Socket Female	6.50
6" End Cap Socket Female	8.31
8" End Cap Socket Female	10.51
10" End Cap Socket Female	9.72
12" End Cap Socket Female	12.20

Specifications to 1/8th of an inch. Subject to change.

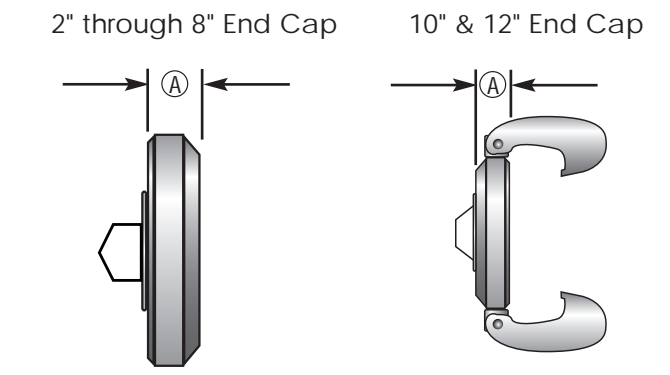

double ball specs.	A
2" Double Ball/Male	10.04
3" Double Ball/Male	11.42
4" Double Ball/Male	16.73
6" Double Ball/Male	15.75
8" Double Ball/Male	18.11

Specifications to 1/8th of an inch. Subject to change.

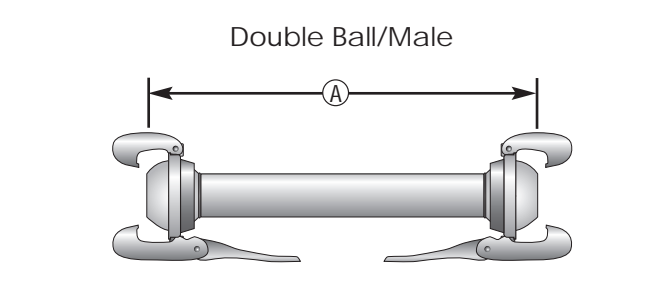

double socket specs.	A
2" Double Socket/Female	4.72
3" Double Socket/Female	4.92
4" Double Socket/Female	6.50
6" Double Socket/Female	7.09
8" Double Socket/Female	10.24

Specifications to 1/8th of an inch. Subject to change.

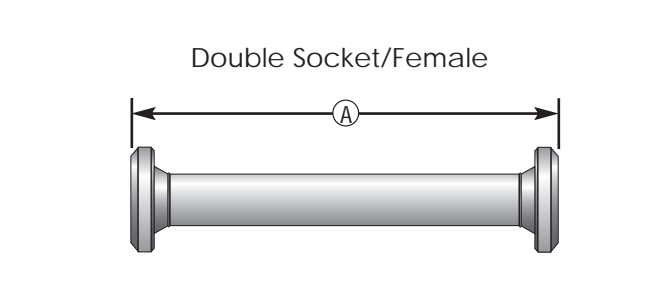

**Tech Tip**

End caps and plugs may be used for several purposes, such as closing off the end of a pipeline, capping unused branches on T's and Y's, vacuum/pressure testing of pumps or pipe, or capping pump fittings during transport.

For easier coupling (especially of larger sizes) lubricate new Wil-loc O-rings. This will allow the ball to seat into the socket easier during first time usage.



steel weld-on sets	part number	weight (lbs.)	list price
2" Black Ball/Skt Weld-On Set	240 BWA2	1.75	22.00
3" Black Ball/Skt Weld-On Set	240 BWA3	3.75	31.88
4" Black Ball/Skt Weld-On Set	240 BWA4	6.05	54.64
5" Black Ball/Skt Weld-On Set	240 BWA5	8.75	78.96
6" Black Ball/Skt Weld-On Set	240 BWA6	13.68	101.12
8" Black Ball/Skt Weld-On Set	240 BWA8	24.00	189.24



steel weld-on balls	part number	weight (lbs.)	list price
2" Ball/Male Black	255 B2B	0.50	3.76
3" Ball/Male Black	255 B3B	0.70	5.11
4" Ball/Male Black	255 B4B	1.05	10.86
5" Ball/Male Black	255 B5B	2.00	13.51
6" Ball/Male Black	255 B6B	2.75	16.60
8" Ball/Male Black	255 B8B	4.75	33.21



steel weld-on sockets	part number	weight (lbs.)	list price
2" Socket/Female Black	257 S2B	0.40	5.05
3" Socket/Female Black	257 S3B	0.80	6.88
4" Socket/Female Black	257 S4B	1.00	13.07
5" Socket/Female Black	257 S5B	2.00	21.53
6" Socket/Female Black	257 S6B	2.95	26.39
8" Socket/Female Black	257 S8B	4.03	51.07



steel weld-on levers	part number	weight (lbs.)	list price
2" Lever Locking Ring Black	274 LR2B	0.98	13.21
3" Lever Locking Ring Black	274 LR3B	1.88	19.89
4" Lever Locking Ring Black	274 LR4B	4.70	30.71
5" Lever Locking Ring Black	274 LR5B	6.00	41.90
6" Lever Locking Ring Black	274 LR6B	9.00	58.11
8" Lever Locking Ring Black	274 LR8B	13.00	104.96



oil resistant o-rings	part number	weight (lbs.)	list price
2" Oil Resistant O-Ring	285 OR2R	0.05	3.25
3" Oil Resistant O-Ring	285 OR3R	0.10	4.25
4" Oil Resistant O-Ring	285 OR4R	0.20	7.20
6" Oil Resistant O-Ring	285 OR6R	0.50	12.50
8" Oil Resistant O-Ring	285 OR8R	0.55	22.00

Wil-loc B-Style Carbon Steel Weld-Ons

vacuum rating 30 inches hg  
psi rating 2 & 3 inch = 290  
4 - 8 inch = 175

weld-on set specs.	A	B	C	D	E
2" Weld-On Set	2.68	6.10	7.09	3.35	4.92
3" Weld-On Set	3.43	7.87	9.25	3.54	7.09
4" Weld-On Set	5.28	11.81	10.83	6.69	9.25
5" Weld-On Set	4.69	11.22	11.42	5.51	10.83
6" Weld-On Set	4.84	12.60	13.39	6.30	11.81
8" Weld-On Set	6.30	15.35	13.19	9.06	13.98

Specifications to 1/100th of an inch • Specifications Subject to Change

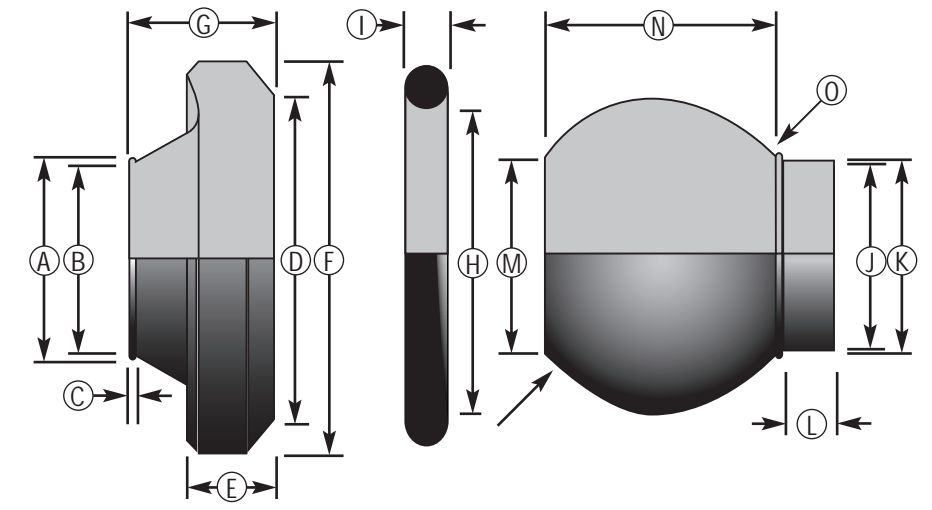
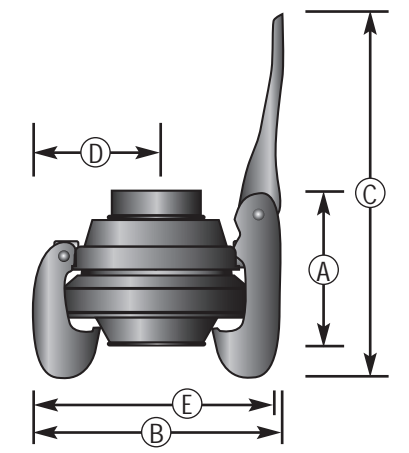

specs.	A	B	C	D	E	F	G	H	I	J	K	L	M	N	O
2" Weld-On	2.01	1.91	0.24	2.83	0.67	3.27	1.22	2.44	0.37	1.91	2.01	0.28	1.97	2.17	2.76
3" Weld-On	3.07	2.99	0.28	3.86	0.87	4.57	1.46	3.48	0.51	2.99	3.07	0.55	3.19	2.87	3.86
4" Weld-On	4.37	4.25	0.47	5.79	1.10	6.50	2.32	5.20	0.59	4.25	4.37	0.59	4.41	4.21	5.71
5" Weld-On	5.39	5.20	0.47	6.42	1.34	7.52	2.13	5.98	0.71	5.20	5.39	0.67	5.39	3.78	6.26
6" Weld-On	6.42	6.22	0.59	7.17	1.34	8.31	2.05	6.69	0.75	6.22	6.42	0.75	6.10	4.06	7.09
8" Weld-On	7.95	7.64	0.71	9.09	1.34	10.51	2.99	8.66	0.75	7.64	7.87	0.67	7.87	5.00	9.06

Specifications to 1/100th of an inch • Specifications Subject to Change

Tech Tip

Virtually any plumbing configuration may be fabricated using the Wil-loc Carbon Steel Weld-On Fittings. Please check columns A & K for correct pipe sizing. IPSO and ODA pipe may be used with steel weld-on fittings.

When fabricating customized fittings, ensure there is enough length for the locking levers to fully close without restriction. The minimum shank lengths are given on the flange specifications pages of this catalog.



weld-on set	part number	weight (lbs.)	list price
10" Weld-On Set	241 BWA10	32.20	158.80



weld-on set	part number	weight (lbs.)	list price
12" Weld-On Set	241 BWA12	61.00	324.16
*12" set comes with a closing bar			



weld-on socket	part number	weight (lbs.)	list price
10" Black Socket/Female	258 S10B	14.55	80.11



weld-on socket	part number	weight (lbs.)	list price
12" Black Socket/Female	258 S12B	28.75	185.15
*12" set comes with a closing bar			



weld-on balls	part number	weight (lbs.)	list price
10" Black Ball/Male	256 B10B	9.75	42.74
12" Black Ball/Male	256 B12B	17.00	77.14



weld-on locking ring	part number	weight (lbs.)	list price
10" Black Locking Ring	259 B10R	7.90	35.97
12" Black Locking Ring	259 B12R	12.75	61.84



oil resistant o-rings	part number	weight (lbs.)	list price
10" Oil Resistant O-Rings	286 OR10R	1.05	31.00
12" Oil Resistant O-Rings	286 OR12R	1.55	35.00

Wil-loc A-Style Carbon Steel Weld-Ons

vacuum rating 30 inches hg

pressure rating 88 psi

Note: 12" locking rings come with a removable locking bar

weld-on set specs.	A	B	C
10" Weld-On Set	9.06	20.08	15.35
12" Weld-On Set	10.24	24.21	10.43
Specifications to 1/100th of an inch.			

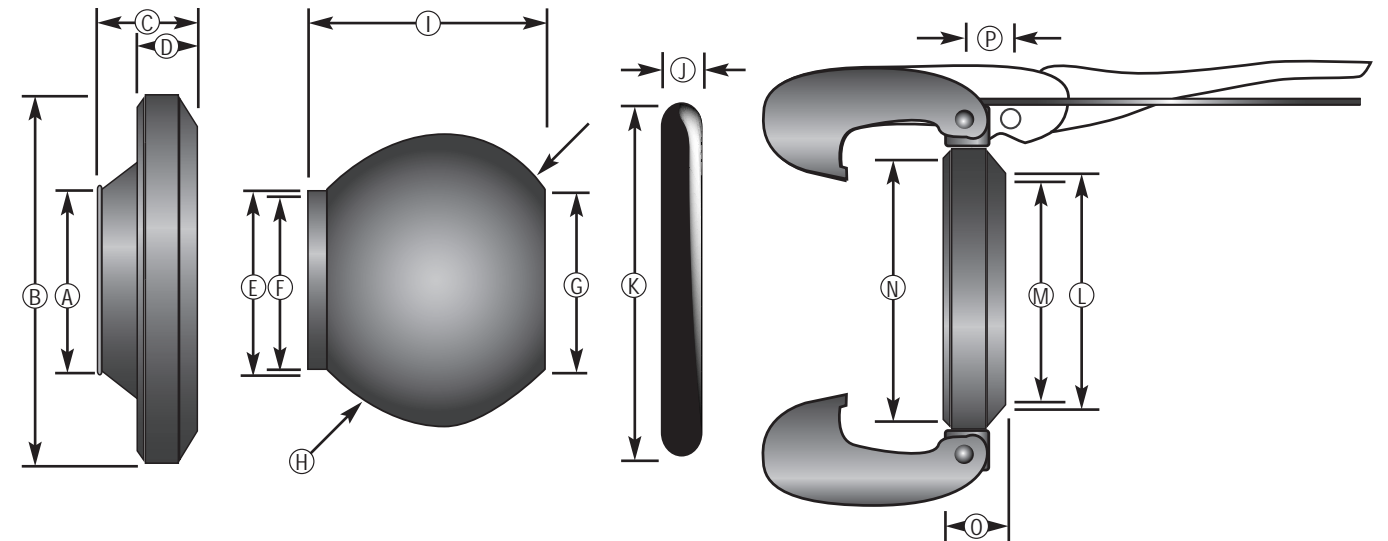
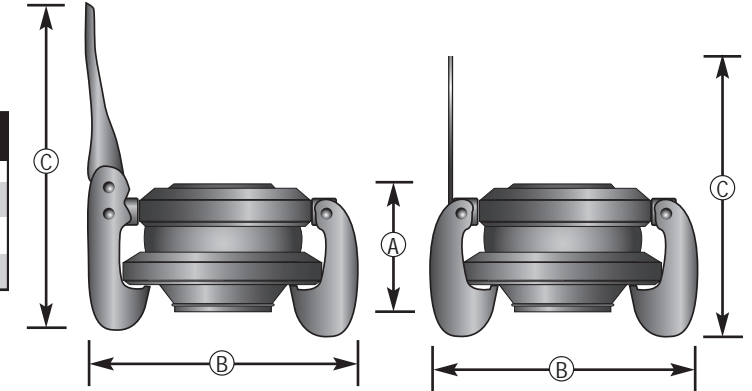

specs.	A	B	C	D	E	F	G	H	I	J	K	L	M	N	O	P
10" Weld-On	11.14	14.09	2.40	1.42	9.57	9.25	9.96	11.81	6.73	0.86	11.06	9.72	9.37	11.89	4.33	1.38
12" Weld-On	13.35	17.56	2.76	1.69	12.01	11.65	11.97	14.57	8.35	0.93	13.98	12.20	11.85	14.65	4.92	1.65
Specifications to 1/100th of an inch • Specifications Subject to Change.																

Tech Tip

For applications that prohibit use of hot-dipped galvanized pipe and fittings, Wil-loc Black Weld-Ons and O-Rings may be specially plated or coated to fit your needs. Epoxy-painted, zinc-plated and fused-Teflon coatings are available.

Before welding, check to make sure locking ring can slide over the O.D. of your pipe. If not, place locking ring over the pipe and weld the male fitting onto the end of the pipe.



complete weld-on sets	part number	weight (lbs.)	list price
2" Aluminum Weld-On Set	732 AWA2	1.60	49.36
3" Aluminum Weld-On Set	732 AWA3	3.55	87.84
4" Aluminum Weld-On Set	732 AWA4	7.00	104.76
5" Aluminum Weld-On Set	732 AWA5	12.00	143.96
6" Aluminum Weld-On Set	732 AWA6	14.00	178.92
8" Aluminum Weld-On Set	732 AWA8	20.50	303.64



weld-on balls	part number	weight (lbs.)	list price
2" Aluminum Ball	732 BA2	0.25	16.65
3" Aluminum Ball	732 BA3	0.50	22.43
4" Aluminum Ball	732 BA4	1.15	30.35
5" Aluminum Ball	732 BA5	4.00	39.52
6" Aluminum Ball	732 BA6	2.15	46.56
8" Aluminum Ball	732 BA8	3.40	74.33



weld-on sockets	part number	weight (lbs.)	list price
2" Aluminum Sockets	734 AA2	0.35	17.03
3" Aluminum Sockets	734 AA3	0.70	23.88
4" Aluminum Sockets	734 AA4	1.40	32.86
5" Aluminum Sockets	734 AA5	2.00	44.55
6" Aluminum Sockets	734 AA6	2.55	51.71
8" Aluminum Sockets	734 AA8	4.15	91.29

**Wil-loc Cast Aluminum Weld-Ons**

vacuum rating 30 inches hg  
 psi rating 2 & 3 inch = 290  
 4 - 8 inch = 175

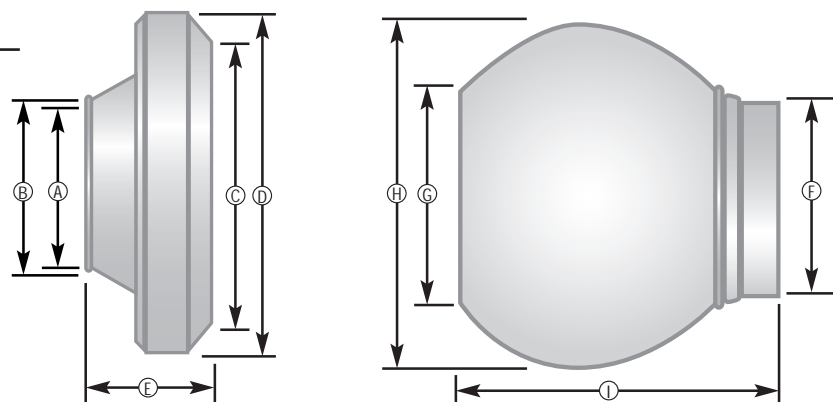

male mechanical specs.	A	B	C	D	E	F	G	H	I
2" Aluminum Weld-On	2.01	2.28	2.80	3.54	1.42	2.36	1.89	2.80	2.32
3" Aluminum Weld-On	3.01	3.35	3.88	4.88	1.65	3.39	2.99	3.86	3.15
4" Aluminum Weld-On	4.02	4.41	5.67	6.69	2.20	4.37	4.21	5.67	4.41
5" Aluminum Weld-On	5.04	5.35	5.98	7.72	2.36	5.31	4.88	6.26	5.20
6" Aluminum Weld-On	6.04	6.42	7.13	8.50	2.44	6.38	5.55	7.09	5.39
8" Aluminum Weld-On	8.01	8.86	9.13	10.71	3.27	8.39	7.72	9.06	6.46

Hose Set Specifications to 1/100th of an inch • Specifications Subject to Change



complete hose sets (al)	part number	weight (lbs.)	list price
2" Hose Set Assembly	775 HSAA2	2.75	121.50
3" Hose Set Assembly	775 HSAA3	6.35	138.08
4" Hose Set Assembly	775 HSAA4	10.45	190.99
6" Hose Set Assembly	775 HSAA6	22.40	300.46
8" Hose Set Assembly	775 HSAA8	33.55	487.11



male hose ends (al)	part number	weight (lbs.)	list price
2" Hose Tail Ball/Male	760 HTMA2	0.75	51.36
3" Hose Tail Ball/Male	760 HTMA3	1.75	53.18
4" Hose Tail Ball/Male	760 HTMA4	3.00	69.69
6" Hose Tail Ball/Male	760 HTMA6	6.15	99.98
8" Hose Tail Ball/Male	760 HTMA8	9.40	162.46



female hose ends (al)	part number	weight (lbs.)	list price
2" Hose Tail Socket/Female	770 HTFA2	1.00	52.06
3" Hose Tail Socket/Female	770 HTFA3	2.25	55.37
4" Hose Tail Socket/Female	770 HTFA4	3.00	73.54
6" Hose Tail Socket/Female	770 HTFA6	7.00	107.70
8" Hose Tail Socket/Female	770 HTFA8	11.15	165.89

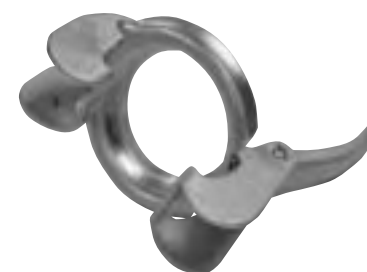

locking levers galvanized	part number	weight (lbs.)	list price
2" Lever Locking Ring	273 LR2	1.05	15.72
3" Lever Locking Ring	273 LR3	2.35	25.69
4" Lever Locking Ring	273 LR4	4.45	41.53
6" Lever Locking Ring	273 LR6	9.25	80.68
8" Lever Locking Ring	273 LR8	13.00	138.05

**Tech Tip**

Wil-loc Aluminum fittings are completely interchangeable with Wil-loc Galvanized steel or Stainless steel fittings. For certain applications, where weight is a concern, aluminum fittings may be the best solution.

Wil-loc Aluminum Weld-Ons are manufactured using a mold cast aluminum process, producing a high quality, consistent part that welds quickly and easily to aluminum pipe or components.



discharge flanges (al)	part number	weight (lbs.)	list price
3" Flange Ball/Male	710 FA3M	8.85	170.09
4" Flange Ball/Male	710 FA4M	15.60	210.25
6" Flange Ball/Male	710 FA6M	29.75	320.62
8" Flange Ball/Male	710 FA8M	41.40	478.00
All flanges are designed to meet ASA specifications			



suction flanges (al)	part number	weight (lbs.)	list price
3" Flange Socket/Female	730 FA3F	4.70	132.35
4" Flange Socket/Female	730 FA4F	9.40	149.57
6" Flange Socket/Female	730 FA6F	13.55	202.88
8" Flange Socket/Female	730 FA8F	19.15	288.96
All flanges are designed to meet ASA specifications			



male threaded long balls (al)	part number	weight (lbs.)	list price
2" Male Thrd/Long/Ball	720 BMTA2	4.50	85.68
3" Male Thrd/Long/Ball	720 BMTA3	8.85	129.59
4" Male Thrd/Long/Ball	720 BMTA4	17.60	174.78
6" Male Thrd/Long/Ball	720 BMTA6	31.75	312.46
8" Male Thrd/Long/Ball	720 BMTA8	45.40	506.22
All threads are cut to NPT specifications			



female threaded balls (al)	part number	weight (lbs.)	list price
2" Female Thrd/Ball/Male	725 BFTA2	2.90	100.73
3" Female Thrd/Ball/Male	725 BFTA3	5.05	159.83
4" Female Thrd/Ball/Male	725 BFTA4	8.85	249.21
6" Female Thrd/Ball/Male	725 BFTA6	16.00	666.47
All threads are cut to NPT specifications			



male threaded sockets (al)	part number	weight (lbs.)	list price
2" Male Thrd/Socket/Female	740 SMTA2	4.50	53.13
3" Male Thrd/Socket/Female	740 SMTA3	5.70	83.02
4" Male Thrd/Socket/Female	740 SMTA4	6.40	104.50
6" Male Thrd/Socket/Female	740 SMTA6	13.55	177.61
8" Male Thrd/Socket/Female	740 SMTA8	21.15	297.08
All threads are cut to NPT specifications			

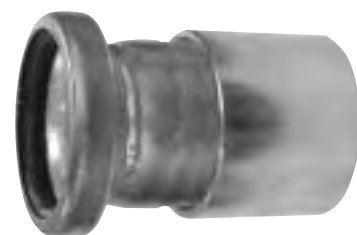

female threaded sockets (al)	part number	weight (lbs.)	list price
2" Female Thrd/Skt/Female	745 SFTA2	1.85	48.13
3" Female Thrd/Skt/Female	745 SFTA3	2.70	69.46
4" Female Thrd/Skt/Female	745 SFTA4	4.40	103.75
6" Female Thrd/Skt/Female	745 SFTA6	6.75	182.53
All threads are cut to NPT specifications			



90° elbow (al)	part number	weight (lbs.)	list price
2" 90 Degree Elbow	770 EA2-90	5.00	135.34
3" 90 Degree Elbow	770 EA3-90	8.55	171.83
4" 90 Degree Elbow	770 EA4-90	16.00	226.30
6" 90 Degree Elbow	770 EA6-90	32.00	378.57
8" 90 Degree Elbow	770 EA8-90	47.50	585.29

45° elbow (al)	part number	weight (lbs.)	list price
2" 45 Degree Elbow	780 EA2-45	5.00	113.69
3" 45 Degree Elbow	780 EA3-45	8.55	149.57
4" 45 Degree Elbow	780 EA4-45	15.00	200.54
6" 45 Degree Elbow	780 EA6-45	30.00	341.30
8" 45 Degree Elbow	780 EA8-45	44.50	542.66

increasers (al)	part number	weight (lbs.)	list price
2" x 3" Increaser	750 INA2-3M	7.70	137.41
3" x 4" Increaser	750 INA3-4M	14.30	187.86
4" x 6" Increaser	750 INA4-6M	27.30	293.96
6" x 8" Increaser	750 INA6-8M	42.00	385.47

reducers (al)	part number	weight (lbs.)	list price
3" x 2" Reducer	760 RA3-2M	5.00	123.37
4" x 3" Reducer	760 RA4-3M	10.25	164.90
6" x 4" Reducer	760 RA6-4M	16.50	236.93
8" x 6" Reducer	760 RA8-6M	34.50	392.15

#### Tech Tip

Certain chemicals may cause extensive acceleration of aluminum corrosion. It is important to check chemical compatibility charts before using aluminum fittings or pipe in certain applications.



stainless steel weld-on sets	part number	weight (lbs.)	list price
2" Stainless Weld-On Set	840 BWAS2	1.95	90.68
3" Stainless Weld-On Set	840 BWAS3	3.85	154.28
4" Stainless Weld-On Set	840 BWAS4	6.70	273.32
6" Stainless Weld-On Set	840 BWAS6	14.95	423.12
8" Stainless Weld-On Set	840 BWAS8	21.78	635.24
Call for minimum quantities & delivery times			



stainless steel weld-on balls	part number	weight (lbs.)	list price
2" Ball/Male Stainless Steel	855 BS2	0.50	34.47
3" Ball/Male Stainless Steel	855 BS3	0.70	55.11
4" Ball/Male Stainless Steel	855 BS4	1.05	107.63
6" Ball/Male Stainless Steel	855 BS6	2.75	139.58
8" Ball/Male Stainless Steel	855 BS8	4.75	216.85
Call for minimum quantities & delivery times			



stainless steel weld-on sockets	part number	weight (lbs.)	list price
2" Skt/Female Stainless Steel	857 SS2	0.40	40.53
3" Skt/Female Stainless Steel	857 SS3	0.80	73.48
4" Skt/Female Stainless Steel	857 SS4	1.20	124.17
6" Skt/Female Stainless Steel	857 SS6	2.95	202.89
8" Skt/Female Stainless Steel	857 SS8	4.03	280.37
Call for minimum quantities & delivery times			

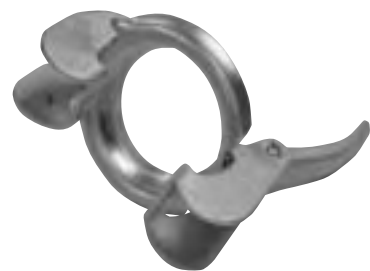

galvanized locking levers	part number	weight (lbs.)	list price
2" Lever Locking Ring	273 LR2	1.05	15.72
3" Lever Locking Ring	273 LR3	2.35	25.69
4" Lever Locking Ring	273 LR4	4.45	41.53
6" Lever Locking Ring	273 LR6	9.25	80.68
8" Lever Locking Ring	273 LR8	13.00	138.05



viton™ o-rings	part number	weight (lbs.)	list price
2" Viton O-Ring	880 VOR2		call
3" Viton O-Ring	880 VOR3		call
4" Viton O-Ring	880 VOR4		call
6" Viton O-Ring	880 VOR6		call
8" Viton O-Ring	880 VOR8		call

### Wil-loc Stainless Steel Weld-Ons

vacuum rating 30 inches hg metallurgy 304: standard  
 psi rating 2 & 3 inch = 290 316: optional  
 4 - 8 inch = 175

weld-on set specs.	A	B	C
2" Weld-On Set	2.68	6.10	7.09
3" Weld-On Set	3.43	7.87	9.25
4" Weld-On Set	5.28	11.81	10.83
5" Weld-On Set	4.69	11.22	11.42
6" Weld-On Set	4.84	12.60	13.39
8" Weld-On Set	6.30	15.35	13.19

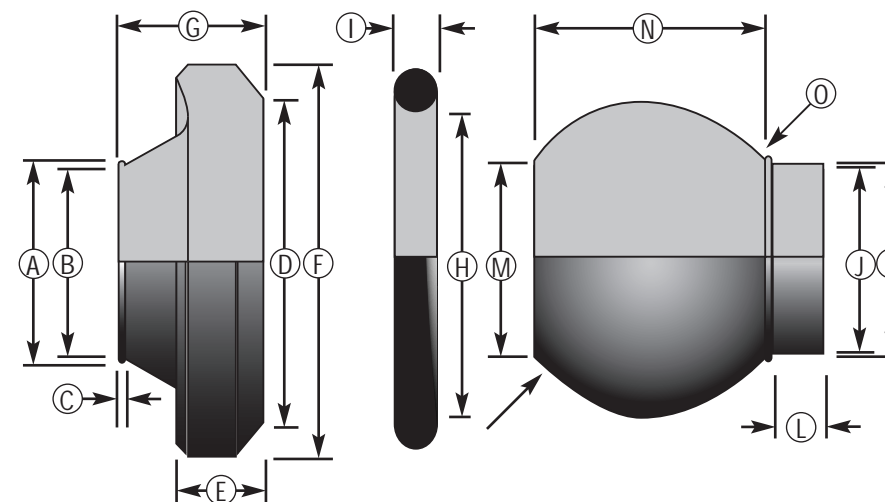
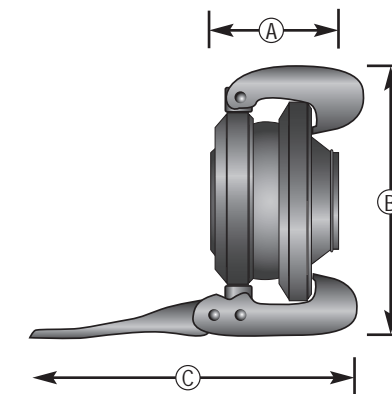

specs.	A	B	C	D	E	F	G	H	I	J	K	L	M	N	O
2" Weld-On	2.01	1.91	0.24	2.83	0.67	3.27	1.22	2.44	0.37	1.91	2.01	0.28	1.97	2.17	2.76
3" Weld-On	3.07	2.99	0.28	3.86	0.87	4.57	1.46	3.48	0.51	2.99	3.07	0.55	3.19	2.87	3.86
4" Weld-On	4.37	4.25	0.47	5.79	1.10	6.50	2.32	5.20	0.59	4.25	4.37	0.59	4.41	4.21	5.71
5" Weld-On	5.39	5.20	0.47	6.42	1.34	7.52	2.13	5.98	0.71	5.20	5.39	0.67	5.39	3.78	6.26
6" Weld-On	6.42	6.22	0.59	7.17	1.34	8.31	2.05	6.69	0.75	6.22	6.42	0.75	6.10	4.06	7.09
8" Weld-On	7.95	7.64	0.71	9.09	1.34	10.51	2.99	8.66	0.75	7.64	7.87	0.67	7.87	5.00	9.06

Specifications to 1/100th of an inch • Specifications Subject to Change

### Tech Tip

Virtually any plumbing configuration may be fabricated using the Wil-loc Stainless Steel Weld-On fittings. Please check columns A & K for correct pipe sizing. IPSO and ODA pipe may be used with stainless steel weld-on fittings.

When fabricating customized fittings, ensure there is enough length for the locking levers to fully close without restriction. The minimum shank lengths are given on the flange specifications pages of this catalog.



complete hose sets (ss)	part number	weight (lbs.)	list price
2" Hose Set Assembly	875 HSAS2	2.45	180.04
3" Hose Set Assembly	875 HSAS3	5.30	272.37
4" Hose Set Assembly	875 HSAS4	10.45	519.43
6" Hose Set Assembly	875 HSAS6	21.70	694.00
8" Hose Set Assembly	875 HSAS8	35.70	1,192.50



male hose ends (ss)	part number	weight (lbs.)	list price
2" Hose Tail Ball/Male	860 HTMS2	0.65	77.37
3" Hose Tail Ball/Male	860 HTMS3	1.45	110.86
4" Hose Tail Ball/Male	860 HTMS4	3.10	212.58
6" Hose Tail Ball/Male	860 HTMS6	5.85	253.51
8" Hose Tail Ball/Male	860 HTMS8	10.70	476.58



female hose ends (ss)	part number	weight (lbs.)	list price
2" Hose Tail Socket/Female	870 HTFS2	0.75	84.62
3" Hose Tail Socket/Female	870 HTFS3	1.50	131.96
4" Hose Tail Socket/Female	870 HTFS4	2.90	259.14
6" Hose Tail Socket/Female	870 HTFS6	6.60	347.70
8" Hose Tail Socket/Female	870 HTFS8	12.00	558.30



locking levers galvanized	part number	weight (lbs.)	list price
2" Lever Locking Ring/Galv	273 LR2	1.05	15.72
3" Lever Locking Ring/Galv	273 LR3	2.35	25.69
4" Lever Locking Ring/Galv	273 LR4	4.45	41.53
5" Lever Locking Ring/Galv	273 LR5	6.40	59.88
6" Lever Locking Ring/Galv	273 LR6	9.25	80.68
8" Lever Locking Ring/Galv	273 LR8	13.00	138.05



silicone o-rings	part number	weight (lbs.)	list price
2" Silicone O-Ring	780 SOR2		call
3" Silicone O-Ring	780 SOR3		call
4" Silicone O-Ring	780 SOR4		call
6" Silicone O-Ring	780 SOR6		call
8" Silicone O-Ring	780 SOR8		call

### Wil-loc Stainless Steel Male Hose Tails

vacuum rating 30 inches hg  
 psi rating 2 & 3 inch = 290  
 4 - 8 inch = 175  
 number of ribs 2 & 3 inch = 2  
 4 - 8 inch = 3  
 metallurgy 304: standard  
 316: optional

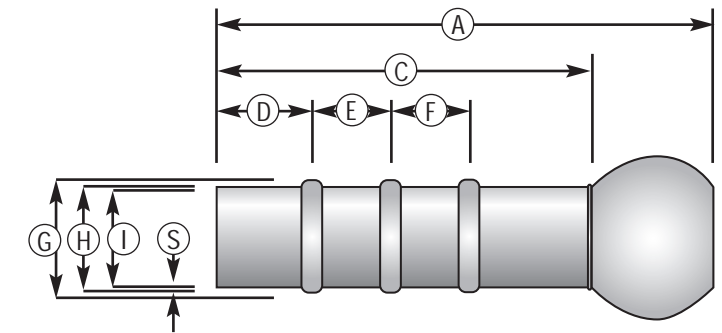

male mechanical specs.	A	C	D	E	F	G	H	I	S
2" 50x50mm	6.50	4.33	0.98	1.38		2.09	1.97	1.85	0.06
3" 76x76mm	8.07	5.31	1.38	1.38		3.11	2.99	2.87	0.06
4" 108x100mm	11.42	7.28	1.38	1.77	1.77	4.09	3.94	3.80	0.07
5" 133x125mm	11.61	7.87	1.38	1.77	1.77	5.08	4.92	4.78	0.07
6" 159x150mm	12.40	8.66	1.57	1.97	1.97	6.06	5.91	5.77	0.07
8" 194x200mm	14.96	9.84	1.97	2.36	2.36	8.11	7.87	7.71	0.08

Hose Set Specifications to 1/100th of an inch • Specifications Subject to Change

### Wil-loc Stainless Steel Female Hose Tails

vacuum rating 30 inches hg  
 psi rating 2 & 3 inch = 290  
 4 - 8 inch = 175  
 number of ribs 2 & 3 inch = 2  
 4 - 8 inch = 3  
 metallurgy 304: standard  
 316: optional

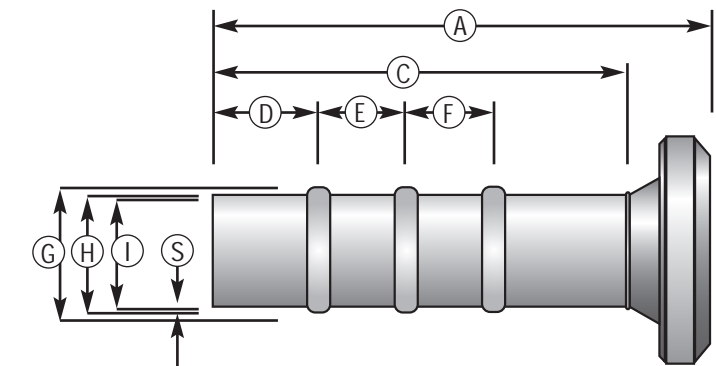

female mechanical specs.	A	C	D	E	F	G	H	I	S
2" 50x50mm	5.51	4.33	0.98	1.38		2.09	1.97	1.85	0.06
3" 76x76mm	6.69	5.31	1.38	1.38		3.11	2.99	2.87	0.06
4" 108x100mm	9.45	7.28	1.38	1.77	1.77	4.09	3.94	3.80	0.07
5" 133x125mm	10.04	7.87	1.38	1.77	1.77	5.08	4.92	4.78	0.07
6" 159x150mm	10.43	8.46	1.57	1.97	1.97	6.06	5.77	5.76	0.07
8" 194x200mm	12.99	9.84	1.97	2.36	2.36	8.11	7.71	7.72	0.08

Hose Set Specifications to 1/100th of an inch • Specifications Subject to Change

### Tech Tip

All stainless steel fittings are made with 304 series stainless steel. 316 series stainless steel is available by special order. Locking levers are carbon steel and can be coated if needed.



discharge flanges (ss)	part number	weight (lbs.)	list price
3" Flange Ball/Male	810 FS3M	13.15	359.26
4" Flange Ball/Male	810 FS4M	20.60	489.74
6" Flange Ball/Male	810 FS6M	39.25	761.76
8" Flange Ball/Male	810 FS8M	56.40	1,178.43

All flanges are designed to meet ASA specifications.



suction flanges (ss)	part number	weight (lbs.)	list price
3" Flange Socket/Female	830 FS3F	7.70	330.31
4" Flange Socket/Female	830 FS4F	10.90	447.88
6" Flange Socket/Female	830 FS6F	17.05	686.27
8" Flange Socket/Female	830 FS8F	25.15	991.82

All flanges are designed to meet ASA specifications.



male threaded long balls (ss)	part number	weight (lbs.)	list price
2" Male Thrd/Long/Ball	820 BMTS2	2.50	148.95
3" Male Thrd/Long/Ball	820 BMTS3	8.65	243.89
4" Male Thrd/Long/Ball	820 BMTS4	15.80	387.80

All threads are cut to NPT specifications.



male threaded short balls (ss)	part number	weight (lbs.)	list price
2" Male Thrd/short/Ball	822 BMTS2	2.00	104.02
3" Male Thrd/short/Ball	822 BMTS3	7.85	172.93
4" Male Thrd/short/Ball	822 BMTS4	14.10	288.44

All threads are cut to NPT specifications.



male threaded sockets (ss)	part number	weight (lbs.)	list price
2" Male Thrd/Socket/Female	840 SMTS2	2.00	92.36
3" Male Thrd/Socket/Female	840 SMTS3	3.30	164.08
4" Male Thrd/Socket/Female	840 SMTS4	5.60	258.27

All threads are cut to NPT specifications.



female threaded balls (ss)	part number	weight (lbs.)	list price
2" Female Thrd/Ball/Male	825 BFTS2	2.50	151.28
3" Female Thrd/Ball/Male	825 BFTS3	8.85	263.59
4" Female Thrd/Ball/Male	825 BFTS4	15.10	394.67

All threads are cut to NPT specifications.



female threaded sockets (ss)	part number	weight (lbs.)	list price
2" Female Thrd/Skt/Female	845 SFTS2	1.75	138.17
3" Female Thrd/Skt/Female	845 SFTS3	4.00	252.78
4" Female Thrd/Skt/Female	845 SFTS4	6.20	367.82

All threads are cut to NPT specifications.

### Wil-loc Stainless Steel Fittings

vacuum rating 30 inches hg metallurgy 304: standard  
 psi rating 2 & 3 inch = 290 316: optional  
 4 - 8 inch = 175



90° elbow (ss)	part number	weight (lbs.)	list price
2" 90 Degree Elbow	870 ES2-90	5.20	177.07
3" 90 Degree Elbow	870 ES3-90	9.85	306.69
4" 90 Degree Elbow	870 ES4-90	19.00	504.09
6" 90 Degree Elbow	870 ES6-90	40.00	886.06
8" 90 Degree Elbow	870 ES8-90	63.50	1,399.71



45° elbow (ss)	part number	weight (lbs.)	list price
2" 45 Degree Elbow	880 ES2-45	4.70	177.07
3" 45 Degree Elbow	880 ES3-45	8.55	293.58
4" 45 Degree Elbow	880 ES4-45	17.00	484.02
6" 45 Degree Elbow	880 ES6-45	34.00	797.19
8" 45 Degree Elbow	880 ES8-45	52.50	1,242.61



increasers (ss)	part number	weight (lbs.)	list price
2" x 3" Increaser	850 INS2-3M	7.20	309.26
3" x 4" Increaser	850 INS3-4M	13.70	472.47
4" x 6" Increaser	850 INS4-6M	28.20	679.15
6" x 8" Increaser	850 INS6-8M	43.20	996.25



reducers (ss)	part number	weight (lbs.)	list price
3" x 2" Reducer	860 RS3-2M	4.80	312.08
4" x 3" Reducer	860 RS4-3M	9.55	451.13
6" x 4" Reducer	860 RS6-4M	17.60	688.35
8" x 6" Reducer	860 RS8-6M	36.20	959.30

### Tech Tip

Wil-loc stocks Stainless Steel Weld-On Sets and Standard Hose Sets. All other fittings are made to order. Please allow for extended delivery times.



B-style galvanized pipe shown.

four inch galvanized pipe	part number	weight (lbs.)	list price
4" x 6' Galvanized Pipe	220 P4-6	21.00	call
4" x 10' Galvanized Pipe	220 P4-10	33.00	call
4" x 20' Galvanized Pipe	220 P4-20	60.00	call

six inch galvanized pipe	part number	weight (lbs.)	list price
6" x 3' Galvanized Pipe	220 P6-3	28.00	call
6" x 6' Galvanized Pipe	220 P6-6	35.00	call
6" x 10' Galvanized Pipe	220 P6-10	55.00	call
6" x 20' Galvanized Pipe	220 P6-20	93.00	call

eight inch galvanized pipe	part number	weight (lbs.)	list price
8" x 3' Galvanized Pipe	220 P8-3	43.00	call
8" x 6' Galvanized Pipe	220 P8-6	52.00	call
8" x 10' Galvanized Pipe	220 P8-10	78.00	call
8" x 20' Galvanized Pipe	220 P8-20	120.00	call

ten inch galvanized pipe	part number	weight (lbs.)	list price
10" x 10' Galvanized Pipe	221 P10-10	63.00	call
10" x 15' Galvanized Pipe	221 P10-15	165.00	call
10" x 20' Galvanized Pipe	221 P10-20	209.00	call

All ten inch pipe has a-style couplings.

twelve inch galvanized pipe	part number	weight (lbs.)	list price
12" x 10' Galvanized Pipe	221 P12-10	173.00	call
12" x 15' Galvanized Pipe	221 P12-15	225.00	call
12" x 20' Galvanized Pipe	221 P12-20	278.00	call

All twelve inch pipe has a-style couplings.

galvanized pipe specs.	I.D. Inches	Wall Inches	Wall Mill.	Max P.S.I.	Vacuum
4" Galvanized Pipe	4.25	0.059	1.5	175	30
6" Galvanized Pipe	6.00	0.059	1.5	175	30
8" Galvanized Pipe	8.00	0.059	1.5	175	30
10" Galvanized Pipe	10.00	0.079	2.0	88	30
12" Galvanized Pipe	12.00	0.079	2.0	88	30

Specifications to 1/8th of an inch • Specifications Subject to Change



B-style aluminum pipe shown.

three inch aluminum pipe	part number	weight (lbs.)	list price
3" x 10' Aluminum Pipe	720 PA3-10	15.00	call
3" x 20' Aluminum Pipe	720 PA3-20	22.00	call
3" x 30' Aluminum Pipe	720 PA3-30	29.00	call

Custom lengths available upon request.

four inch aluminum pipe	part number	weight (lbs.)	list price
4" x 10' Aluminum Pipe	720 PA4-10	24.00	call
4" x 20' Aluminum Pipe	720 PA4-20	35.00	call
4" x 30' Aluminum Pipe	720 PA4-30	46.00	call

Custom lengths available upon request.

six inch aluminum pipe	part number	weight (lbs.)	list price
6" x 10' Aluminum Pipe	720 PA6-10	46.00	call
6" x 20' Aluminum Pipe	720 PA6-20	64.00	call
6" x 30' Aluminum Pipe	720 PA6-30	82.00	call

Custom lengths available upon request.

eight inch aluminum pipe	part number	weight (lbs.)	list price
8" x 10' Aluminum Pipe	720 PA8-10	68.00	call
8" x 20' Aluminum Pipe	720 PA8-20	96.00	call

Custom lengths available upon request.

aluminum pipe specs.	Fittings	I.D. Inches	Wall Mill.	Max P.S.I.	Vacuum
3" Aluminum Pipe	Cast Alum.	3.00	0.065	290	30
4" Aluminum Pipe	Cast Alum.	4.00	0.072	175	30
6" Aluminum Pipe	Cast Alum.	6.00	0.083	175	30
8" Aluminum Pipe	Cast Alum.	8.00	0.090	175	30

Specifications to 1/8th of an inch • Specifications Subject to Change

#### Tech Tip

Wil-loc's industrial-grade Galvanized and Aluminum Pipe is fully vacuum rated. Vacuum ratings are dependent on the wall thickness of the pipe. For thinner walled pipe, vacuum relief valves should be used to prevent pipe from collapsing.

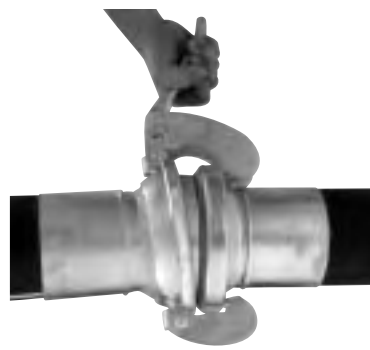

HDPE transition fitting set	part number	weight (lbs.)	list price
2" HDPE Transition Assembly	910 HDTGA2	5.00	192.53
3" HDPE Transition Assembly	910 HDTGA3	10.50	221.68
4" HDPE Transition Assembly	910 HDTGA4	19.00	276.66
6" HDPE Transition Assembly	910 HDTGA6	39.00	418.87
8" HDPE Transition Assembly	910 HDTGA7	58.00	706.73
10" HDPE Transition Assembly	911 HDTGA10	79.00	857.10
12" HDPE Transition Assembly	911 HDTGA12	160.00	1,116.43

10 & 12 inch transition fittings are A-Style fittings.

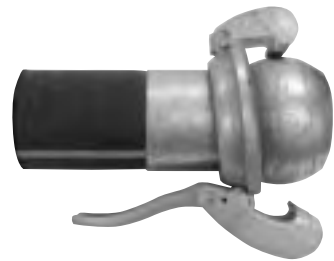

HDPE transition male fitting	part number	weight (lbs.)	list price
2" HDPE Transition Male	920 HDPEMG2	2.00	103.49
3" HDPE Transition Male	920 HDPEMG3	4.00	122.80
4" HDPE Transition Male	920 HDPEMG4	7.50	158.00
6" HDPE Transition Male	920 HDPEMG6	15.00	244.00
8" HDPE Transition Male	920 HDPEMG8	23.00	413.46
10" HDPE Transition Male	921 HDPEMG10	35.00	436.99
12" HDPE Transition Male	921 HDPEMG12	73.00	551.28

Price Includes Locking Rings.



HDPE transition female fitting	part number	weight (lbs.)	list price
2" HDPE Transition Female	940 HDPEFG2	2.00	89.05
3" HDPE Transition Female	940 HDPEFG3	4.00	98.88
4" HDPE Transition Female	940 HDPEFG4	7.50	118.67
6" HDPE Transition Female	940 HDPEFG6	15.00	173.99
8" HDPE Transition Female	940 HDPEFG8	23.00	293.27
10" HDPE Transition Female	941 HDPEFG10	35.00	420.11
12" HDPE Transition Female	941 HDPEFG12	73.00	565.15

10 & 12 inch transition fittings are A-Style fittings.

### HDPE Fused Transition, High Pressure Fittings

stub ends HDPE SDR11  
inserts tapped & coned

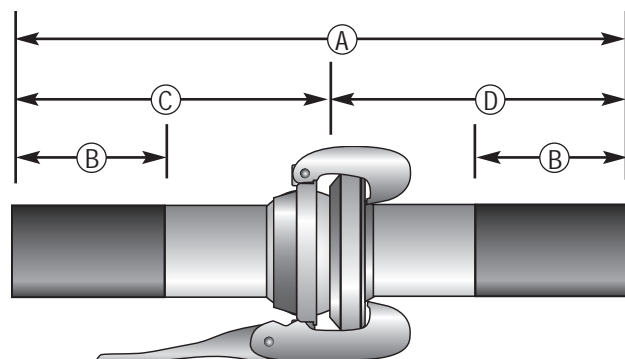
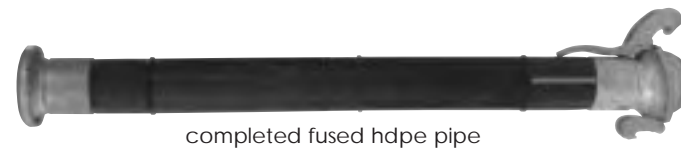

HDPE transition specs.	A	B	C	D
2" HDPE Transition	22.25	6.00	12.00	10.75
3" HDPE Transition	23.25	6.00	13.00	11.00
4" HDPE Transition	25.50	6.00	14.25	11.75
6" HDPE Transition	27.00	6.00	15.50	12.50
8" HDPE Transition	32.25	6.00	18.00	15.25
10" HDPE Transition	38.75	6.00	21.25	18.75
12" HDPE Transition	41.00	6.00	22.75	19.50

Specifications to 1/8th of an inch. Subject to change.



B-style fitting shown.



B-Style HDPE insert fittings	part number	weight (lbs.)	list price
2" Hose Set Assembly	275 HSA2	2.60	38.05
3" Hose Set Assembly	275 HSA3	5.30	59.40
4" Hose Set Assembly	275 HSA4	11.70	106.25
6" Hose Set Assembly	275 HSA6	21.70	189.40
8" Hose Set Assembly	275 HSA8	35.70	369.75

A-Style HDPE insert fittings	part number	weight (lbs.)	list price
10" Hose Set Assembly	276 HSA10	55.04	434.35
12" Hose Set Assembly*	276 HSA12	89.60	721.80

\* 12" Hose Set Assembly comes with a locking bar.

HDPE single bolt clamps	part number	weight (lbs.)	list price
2" HDPE Clamp	302 CS2	59-63	5.00
3" HDPE Clamp	302 CS3	85-91	8.00
4" HDPE Clamp	302 CS4	112-121	9.20
6" HDPE Clamp	302 CS6	162-174	14.50
8" HDPE Clamp	302 CS8	213-226	16.00
10" HDPE Clamp	302 CS10	265-278	38.00
12" HDPE Clamp	302 C12	317-330	45.20

### HDPE Press-In Fittings

male hose barb

female hose barb



HDPE specs.	P.S.I*	Weight/Ft.	Clamp
2" SDR 11 / SDR 17	160/100	0.64/0.43	59-63
3" SDR 17 / SDR 21	100/80	0.93/0.77	85-91
4" SDR 17 / SDR 21 / SDR 26	100/80/64	1.54/1.26/1.03	112-121
6" SDR 17 / SDR 21 / SDR 26	100/80/64	3.34/2.73/2.23	162-174
8" SDR 21 / SDR 26 / SDR 32.5	80/64/51	4.64/3.79/3.05	213-226
10" SDR 21 / SDR 26 / SDR 32.5	80/64/51	7.21/5.87/4.73	265-278
12" SDR 26 / SDR 32.5	64/51	8.26/6.67	317/330

HDPE expands / contracts at 1" / 100' for every 10° temperature variance from 70°



PVC single bolt clamps	part number	mm range	list price
2" PVC Discharge	302 CD2	51-55	5.20
3" PVC Discharge	302 CD3	79-85	7.95
4" PVC Discharge	302 CD4	104-112	9.10
5" PVC Discharge	302 CD5	130-140	13.60
6" PVC Discharge	302 CD6	150-162	14.15
8" PVC Discharge	302 CD8	200-213	15.70

rubber single bolt clamps	part number	mm range	list price
2" Rubber Discharge	302 CD2X	55-59	5.40
3" Rubber Discharge	302 CS3	85-91	8.00
4" Rubber Discharge	302 CD4X	121-130	9.60
6" Rubber Discharge	302 CD6X	174-187	14.90
8" Rubber Discharge	302 CS8	213-226	16.00

suction single bolt clamps	part number	mm range	list price
2" PVC/Rubber Suction	302 CS2	59-63	5.00
3" PVC/Rubber Suction	302 CS3	85-91	8.00
4" PVC/Rubber Suction	302 CS4	112-121	9.20
5" PVC/Rubber Suction	302 CS5	140-150	13.80
6" PVC/Rubber Suction	302 CS6	162-174	14.50
8" PVC/Rubber Suction	302 CS8	213-226	16.00



The bolt is made from high grade steel, zinc plated (W2) or stainless steel (W4).



Only regular tools are needed to tighten the bolt. Deep sockets to reach a nut are not required.



The stainless steel band has beveled edges to prevent damage to the hose.



lever locking safety pins	part number	weight (lbs.)	list price
2" lever locking pin	009 LLSP2		2.50
3" lever locking pin	009 LLSP3		2.50
4" lever locking pin	009 LLSP4		3.75
6" lever locking pin	009 LLSP6		3.75
8" lever locking pin	009 LLSP8		3.75



PVC ball valves	part number	weight (lbs.)	list price
2" PVC Ball Valve	170 PVCBA2		79.54
3" PVC Ball Valve	170 PVCBA3		190.69
4" PVC Ball Valve	170 PVCBA4		358.80

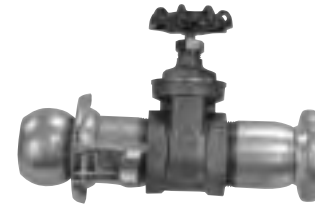

brass gate valves	part number	weight (lbs.)	list price
2" Brass Gate Valve	172 BGVA2		84.83
3" Brass Gate Valve	172 BGVA3		166.63
4" Brass Gate Valve	172 BGVA4		286.74

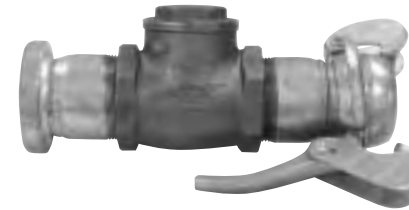

brass check valves	part number	weight (lbs.)	list price
2" Brass Check Valve	173 BCVA2		100.50
3" Brass Check Valve	173 BCVA3		213.58
4" Brass Check Valve	173 BCVA4		359.51



flanged check valves	part number	weight (lbs.)	list price
4" Galvanized Check Valve	174 FGCVA4		1,011.44
6" Galvanized Check Valve	174 FGCVA6		1,112.77
8" Galvanized Check Valve	174 FGCVA8		1,427.73
10" Galvanized Check Valve	174 FGCVA10		1,810.11
12" Galvanized Check Valve	174 FGCVA12		2,558.39

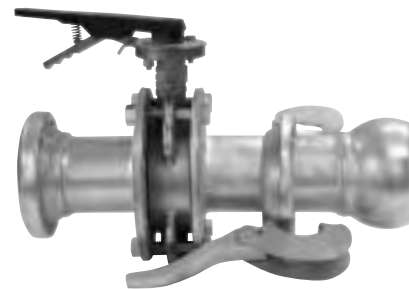

flanged butterfly valves	part number	weight (lbs.)	list price
4" Galv. Butterfly Valve	171 BFVA4		565.80
6" Galv. Butterfly Valve	171 BFVA6		903.01
8" Galv. Butterfly Valve	171 BFVA8		1,275.73
10" Galv. Butterfly Valve	171 BFVA10		1,732.83
12" Galv. Butterfly Valve	171 BFVA12		2,492.03

Note: Stand-alone valves are available for purchase.

#### Tech Tip

Most hoses expand and contract with weather and heavy usage. Wil-loc Bolt Clamps are designed to allow adjustment in the field. To tighten your Wil-loc Clamps, or to remove your valuable hose ends, all you need is an adjustable wrench.

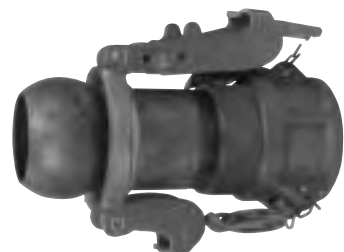

female cam to male ball	part number	weight (lbs.)	list price
2" Female Cam-lock Male	028 BFC2	3.00	49.15
3" Female Cam-lock Male	028 BFC3	6.00	75.76
4" Female Cam-lock Male	028 BFC4	11.00	129.67
6" Female Cam-lock Male	028 BFC6	21.00	240.05

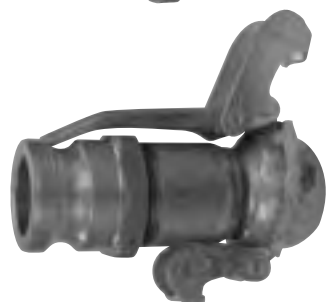

male cam to male ball	part number	weight (lbs.)	list price
2" Male Cam-lock Male	027 BMC2	3.00	41.27
3" Male Cam-lock Male	027 BMC3	6.00	102.46
4" Male Cam-lock Male	027 BMC4	11.00	114.55
6" Male Cam-lock Male	027 BMC6	21.00	208.13

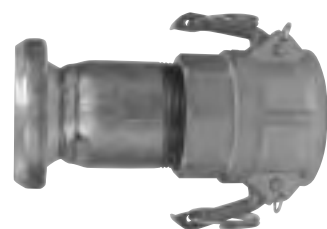

female cam to female skt.	part number	weight (lbs.)	list price
2" Female Cam-lock Socket	048 SFC2	2.00	33.28
3" Female Cam-lock Socket	048 SFC3	4.00	49.60
4" Female Cam-lock Socket	048 SFC4	5.00	87.44
6" Female Cam-lock Socket	048 SFC6	15.00	162.61



male cam to female socket	part number	weight (lbs.)	list price
2" Male Cam-lock Socket	047 SMC2	2.00	25.40
3" Male Cam-lock Socket	047 SMC3	4.00	35.03
4" Male Cam-lock Socket	047 SMC4	5.00	72.32
6" Male Cam-lock Socket	047 SMC6	15.00	130.69



victaulic to male balls	part number	weight (lbs.)	list price
2" Vic / Male Wil-loc	930 VICMG2	3.20	70.24
3" Vic / Male Wil-loc	930 VICMG3	6.55	95.22
4" Vic / Male Wil-loc	930 VICMG4	10.00	133.02
6" Vic / Male Wil-loc	930 VICMG6	21.50	226.55
8" Vic / Male Wil-loc	930 VICMG8	32.25	362.46
10" Vic / Male Wil-loc	931 VICMG10	49.50	331.97
12" Vic / Male Wil-loc	931 VICMG12	77.25	475.30

Note: Clamps sold separately



victaulic to female sockets	part number	weight (lbs.)	list price
2" Vic / Female Wil-loc	932 VICFG2	2.10	53.63
3" Vic / Female Wil-loc	932 VICFG3	4.30	67.71
4" Vic / Female Wil-loc	932 VICFG4	5.50	87.80
6" Vic / Female Wil-loc	932 VICFG6	12.50	145.03
8" Vic / Female Wil-loc	932 VICFG8	19.25	224.24
10" Vic / Female Wil-loc	933 VICFG10	42.50	324.89
12" Vic / Female Wil-loc	933 VICFG12	75.25	526.32

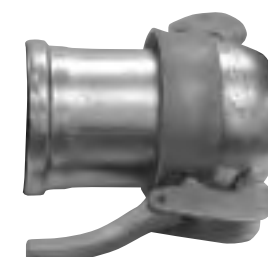

female ring-lock to male balls	part number	weight (lbs.)	list price
4" Female / Male Wil-loc	934 FCMG4	7.25	100.69
6" Female / Male Wil-loc	934 FCMG6	14.50	151.44
8" Female / Male Wil-loc	934 FCMG8	22.25	248.68
10" Female / Male Wil-loc	935 FCMG10	23.15	198.10
12" Female / Male Wil-loc	935 FCMG12	38.75	318.09

Note: Clamps sold separately



male ring-lock to sockets	part number	weight (lbs.)	list price
4" Male / Female Wil-loc	936 MCFG4	2.50	49.60
6" Male / Female Wil-loc	936 MCFG6	5.75	79.55
8" Male / Female Wil-loc	936 MCFG8	8.50	123.68
10" Male / Female Wil-loc	937 MCFG10	20.00	193.64
12" Male / Female Wil-loc	937 MCFG12	37.75	367.85



ban-lock to male aluminum	part number	weight (lbs.)	list price
6" Female / Aluminum Ball	938BM A6	16.00	234.39
8" Female / Aluminum Ball	938BM A8	21.00	376.56

Note: Clamps sold separately



ban-lock to female aluminum	part number	weight (lbs.)	list price
6" Male / Aluminum Socket	939BF A6	7.00	110.35
8" Male / Aluminum Socket	939BF A8	9.50	176.76

#### Tech Tip

The 2" - 6" Cam-lock components used for Wil-loc's Cam-lock adapters are manufactured to MIL-C-274878F specifications. Conformance to this specification assures complete compatibility and product quality control.

Wil-loc offers a wide range of adapters. Contact Wil-loc for any adapter configuration.

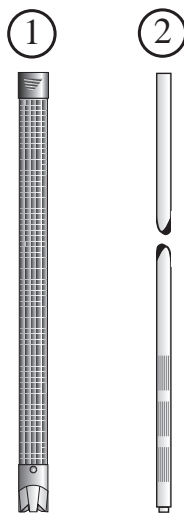

1. self jetting wellpoints	part number	weight (lbs.)	list price
18" Stainless Steel Wellpoints	141 WPS-1	8.00	160.00
28" Stainless Steel Wellpoints	141 WPS	11.00	184.00
screen size .012			

2. PVC wellpoints	part number	weight (lbs.)	list price
1.5" x 20' Wellpoint Fine	141 WPP F	10.00	60.00
1.5" x 20' Wellpoint Medium	141 WPP M	10.00	60.00
1.5" x 20' Wellpoint Coarse	141 WPP C	11.00	60.00
screen sizes; fine = .010, medium = .016, coarse = .025			

steel wellpoint accessories	part number	weight (lbs.)	list price
2" Socket x 1.5" Female Thrd	142 SFT	1.00	26.30
2" Socket x 1.5" Male Thrd	142 SMT	1.00	24.70
2" Socket x 2.0" Female Thrd	142 SFT2	1.00	24.70

four inch header pipes	part number	weight (lbs.)	list price
4" x 10' Header / 3 inlets	140 H4-10-3	41.00	call
4" x 10' Header / 6 inlets	140 H4-10-6	44.00	call
4" x 20' Header / 6 inlets	140 H4-20-6	66.00	call

six inch header pipes	part number	weight (lbs.)	list price
6" x 3' Header / 1 inlet	140 H6-3	34.00	call
6" x 6' Header / 2 inlets	140 H6-6	47.00	call
6" x 10' Header / 3 inlets	140 H6-10	63.00	call
6" x 10' Header / 9 inlets	140 H6-10-9	69.00	call
6" x 20' Header / 6 inlets	140 H6-20	99.00	call
8" galvanized steel wellpoint header pipe available upon request			

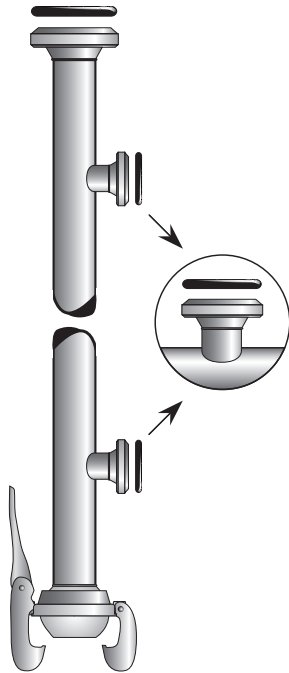

galvanized header pipe specs.	I.D.	Wall Thickness	W.P. P.S.I.	Vac. Rating
4" Galvanized Steel Header	4.25	0.071	175	28 hg.
6" Galvanized Steel Header	6.00	0.071	175	28 hg.
Specifications to 1/8th of an inch & Subject to Change				

Note: 8" Galvanized Steel Header is available. Please allow extra time for delivery.

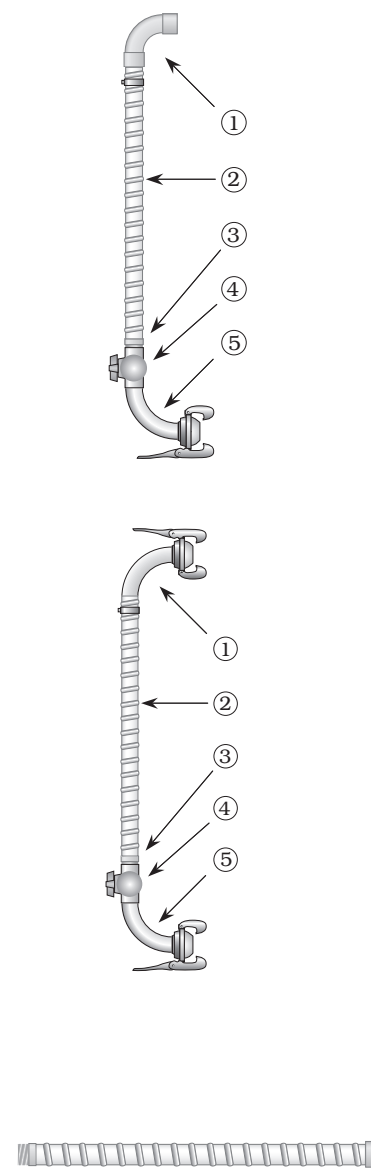

PVC wellpoint swingers	part number	weight (lbs.)	list price
3' PVC Wellpoint Swinger As.	141 SWPA	5.00	114.90
6' PVC Wellpoint Swinger As.	141 SWPA-6	6.00	133.40
9' PVC Wellpoint Swinger As.	141 SWPA-9	8.00	152.00

PVC swinger components	part number	weight (lbs.)	list price
1. PVC Riser to Hose Adapter	142 PRA		5.75
2. Swinger Hose 1.5" x 36"	142 WFHA		17.25
3. PVC Adapter to Threaded	142 PAT		3.45
4. PVC Ball Valve / Threaded	142 PBV		23.00
5. 2" B 90 x 1.5" Male Thrd.	142 B9MT		46.15

steel wellpoint swingers	part number	weight (lbs.)	list price
3' Wellpoint Swinger As.	141 SWSPA	8.00	140.80
6' Wellpoint Swinger As.	141 SWSPA-6	9.00	158.30
9' Wellpoint Swinger As.	141 SWSPA-9	11.00	177.10

steel wellpoint swingers	part number	weight (lbs.)	list price
1. 2" B 90 x 1.5" Male Tail	142 B9H		28.90
2. Swinger Hose 1.5" x 36"	142 WFHA		18.50
3. PVC Adapter to Threaded	142 PAT		3.45
4. PVC Ball Valve / Threaded	142 PBV		23.00
5. 2" B 90 x 1.5" Male Thrd.	142 B9MT		46.10

swinger hose extensions	part number	weight (lbs.)	list price
3' Swinger Hose Extension As.	142 SHEA-3		33.95
6' Swinger Hose Extension As.	142 SHEA-6		44.85
9' Swinger Hose Extension As.	142 SHEA-9		60.95

#### Tech Tip

All of Wil-loc's standard Wellpoint Swingers come with bright red PVC ball valve handles. This makes it very easy for the operator to tell which valves are open and which are closed.

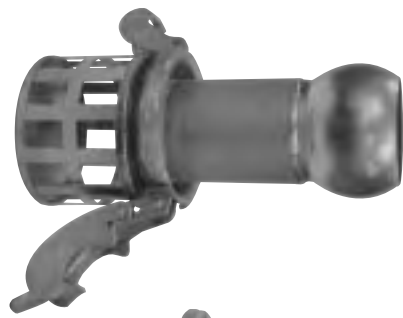

square strainer baskets	part number	weight (lbs.)	list price
2" 2Pc/w/Threaded Ball/Male	316 SBTSA2C	4.50	54.07
3" 2Pc/w/Threaded Ball/Male	316 SBTSA3C	8.05	83.41
4" 2Pc/w/Threaded Ball/Male	316 SBTSA4C	14.00	132.12
6" 2Pc/w/Threaded Ball/Male	316 SBTSA6C	27.15	268.10
8" 2Pc/w/Threaded Ball/Male	316 SBTSA8C	58.55	695.87

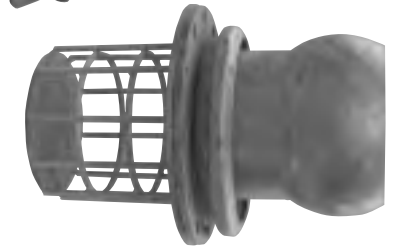

square strainer baskets	part number	weight (lbs.)	list price
10" 2Pc Flange Strainer Ball	316 SBTSA10C	85.00	984.22
12" 2Pc Flange Strainer Ball	316 SBTSA12C	114.00	1,254.42
A-Style coupling			

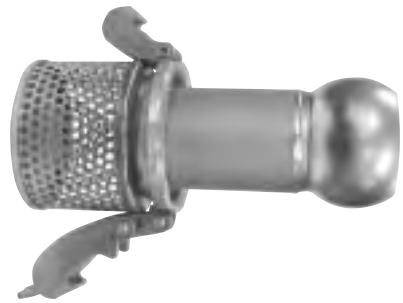

round strainer baskets	part number	weight (lbs.)	list price
2" 2Pc/w/Threaded Ball/Male	319 SBTRA2C	4.90	53.47
3" 2Pc/w/Threaded Ball/Male	319 SBTRA3C	8.75	81.61
4" 2Pc/w/Threaded Ball/Male	319 SBTRA4C	13.20	132.24
6" 2Pc/w/Threaded Ball/Male	319 SBTRA6C	26.95	267.50
8" 2Pc/w/Threaded Ball/Male	319 SBTRA8C	51.40	506.99

round strainer baskets	part number	weight (lbs.)	list price
10" 2Pc/w/Thrd Ball/Male	319 SBTRA10C	53.00	call
12" 2Pc/w/Thrd Ball/Male	319 SBTRA12C	78.00	call
A-Style coupling			



square strainer baskets	part number	weight (lbs.)	list price
10" Flange Square Strainer	316 SFSB10	42.00	366.00
12" Flange Square Strainer	316 SFSB12	48.00	436.00
A-Style coupling			



square replacement baskets	part number	weight (lbs.)	list price
2" Replacement Basket	317 STRB2	1.40	13.52
3" Replacement Basket	317 STRB3	1.95	21.16
4" Replacement Basket	317 STRB4	2.48	22.92
6" Replacement Basket	317 STRB6	6.05	65.24
8" Replacement Basket	317 STRB8	21.00	307.68



round replacement baskets	part number	weight (lbs.)	list price
2" Replacement Basket	318 STRB2	1.80	12.92
3" Replacement Basket	318 STRB3	2.65	19.36
4" Replacement Basket	318 STRB4	2.60	22.44
6" Replacement Basket	318 STRB6	5.80	64.64
8" Replacement Basket	318 STRB8	13.00	118.80

## Wil-loc Custom Fabrication

Wil-loc knows that no job is the same. Sometimes having the right part or piece of equipment can turn a nightmare job into a smooth one. While we have tried to assemble a complete line of quality products for your industrial plumbing needs, sometimes you need a custom piece to get the job done.

Contact Wil-loc and talk to our system specialists to design the perfect custom piece of Wil-loc plumbing.

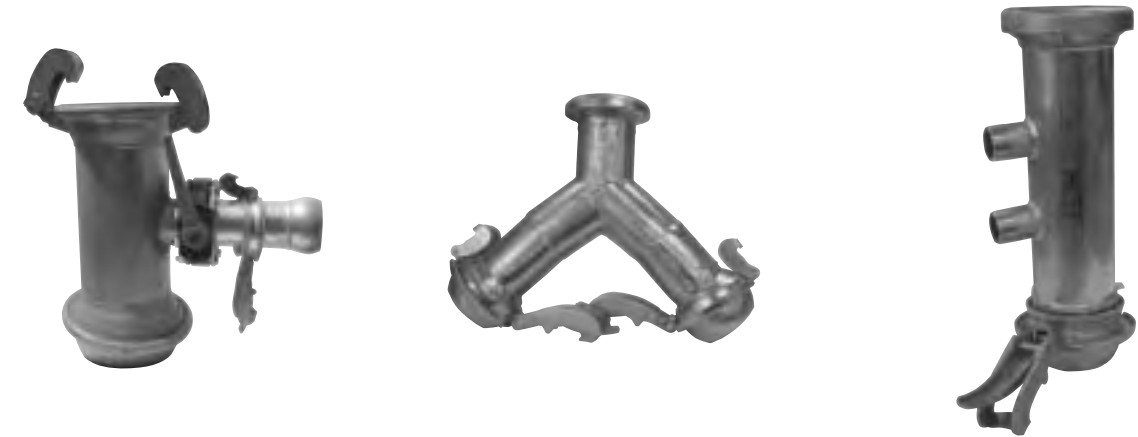

### Tech Tip

Round-hole strainer baskets should be used in clean water applications. With liquids that are higher in viscosity than 1.0 weight, square-hole strainers should be used. While the round-hole strainers will filter out larger solids, they are also more likely to clog.

## terms & conditions

### Acceptance

Unless otherwise stated herein, quotations must be accepted by a purchase order or purchase order acknowledgement in writing within thirty (30) days from the date of the quotation or before shipment of product; whichever is first. All quantities are estimates only. The customer is responsible for actual item quantities required for completion of scope of work. Prices quoted are based upon quantity as indicated. All shipments are subject to prior approval of Purchaser's credit.

### Terms of Payment

Terms are 2% ten (10) days or net thirty (30) days from invoice date, unless otherwise agreed to in writing. Retainage will not be accepted at any terms. All amounts due bear interest during the time they remain unpaid at a rate of 1.5% per month (18% per annum). If the Purchaser shall fail to make payments in accordance to the terms agreed upon, the Seller may defer further shipment until such payments are made or terminate the contract. The Seller may otherwise defer shipment, require payment for any shipment hereunder in advance or terminate the contract if the Purchaser's financial responsibility becomes unsatisfactory to the Seller. Minimum order is \$25.

### Availability

Availability is based upon current inventory levels and production schedules as of the date of the quote. Actual availability can only be determined on the date the order is placed.

### Sales Tax

Unless specifically stated otherwise, quoted prices do not include tax. We are required by law to collect all applicable state and local taxes on orders shipped within Minnesota, and on product the customer picks up at the seller's location. If Purchaser is tax exempt, Purchaser must submit certificate of exemption for Seller's files.

### Liability & Warranty

Having no control over the use of the products of this quote, we assume no liability connected with their use. Under no circumstances is the Seller liable for any loss, damage, or expenses of any kind arising out of the use or inability to use our products. All products are covered by normal manufacturer's warranties. No representative of American Pump Company has the authority to waive, alter, or add provisions to this warranty. This warranty is EXPRESSLY IN LIEU OF ANY OTHER WARRANTIES, EXPRESSED OR IMPLIED, INCLUDING BUT NOT LIMITED TO, any implied warranty or merchantability or fitness for a particular purpose. The buyer's sole and exclusive remedy against American Pump Co., Inc. shall be for the repair or replacement, at the option of American Pump Co., Inc., of defective products as provided herein. No other remedy (including, but not limited to, incidental or consequential damages for lost profits, lost sales, injury to person or property, or any other incidentals or consequential loss) shall be available to buyer.

### Price/Freight Rates

Freight is FOB Shipping Point unless stated otherwise. All freight quotes are estimates only and are subject to actual costs incurred. If the Purchaser requests product to be shipped to a location other than the quoted shipping point, Purchaser is responsible for additional freight costs. Orders that are in stock can be shipped the same day. Most orders are shipped UPS unless instructed otherwise. Oversized or heavy items are shipped via motor freight. If overnight or next day delivery is needed, Seller will ship merchandise by any available express service of Purchaser's choosing at Purchaser's expense.

### Shipping Errors

Any error in weight, number or other specifications must be noted on the bill of lading, and any claim arising therefore must be made in writing within ten (10) days after the receipt by the Purchaser of the equipment, material or goods sold.

### Cancellations

Any order is not subject to cancellation as a whole or in part, and is not subject to change without approval of the Seller. At the Seller's option, changes or cancellations may be made without extra charge on items on which work has not begun. Cancellations of any items on which work has begun will be accepted only upon payment of reasonable charges, taking into account expenses already incurred, and commitments already made by Seller.

### Force Majeure

The Seller shall not be responsible for any direct or indirect damages whatsoever cause by the delays beyond the control of the Seller, and without limiting the generality of the foregoing it shall not be responsible for any damages due to delays cause by fires, strikes, lockouts, labor difficulties, material procedure delays, or any other cause beyond its control.

### Damage in Shipment

Despite our best efforts, items may occasionally be damaged in transit. Freight carriers are liable for damages only when damage is indicated on the bill of lading before you sign for the shipment. Therefore, we recommend that you inspect the outside and contents of all cartons received. If any damage is found, write details on the bill of lading and save the shipment, including the outside container and inside packing material. Ask the delivery carrier to make an inspection immediately. Per ICC regulations, it is the responsibility of the consignee to file a damage claim with the carrier promptly after inspection.

### Returned Material

The amount of credit, if any, allowed to the Purchaser for the materials returned, shall be the sole discretion of the Seller. Most items may be returned within 30 days of receipt. Please call, fax or write our Customer Service Department for a Return Authorization Number and shipping instructions prior to return. Our standard restocking charge is 25%. Shipping charges should be prepaid unless otherwise arranged in advance. All merchandise must be carefully packed and will be subject to a charge if not in saleable condition.

All prices, terms and conditions of sale are subject to change without prior notice. Buyer agrees to all terms and conditions of Seller upon the placement of any and all purchase orders.

## Wil-loc Assembly Instructions

### B- Style Assembly Procedure

*Before coupling new fittings, lightly lubricate the O-Rings with a multipurpose, synthetic grease or a non-petroleum based rubber lubricant. This will extend the life of the O-Ring and provide a smoother, easier coupling action to your Wil-loc fitting*

#### Step 1:

Insert the ball into the socket so that the ball seats loosely against the O-ring inside the socket.

#### Step #1

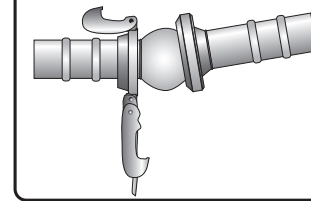

#### Step 2:

Reach around the socket with the "short" locking jaw and seat its gripping edge securely into the grooved lip on the back side of the socket.

#### Step #2

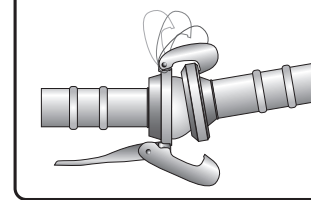

#### Step 3:

While keeping tension on the "short" locking jaw so that it remains in place, open the lever arm attached to the "long" locking jaw so that it extends to reach behind the socket and seat securely into the groove lip.

#### Step #3

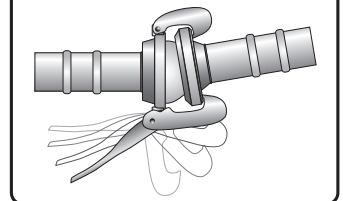

#### Step 4:

Finally, ensure that the leading edge of the ball is aligned just enough so that it does not cut into the O-ring surface, then close the lever arm (or pull back towards the barbed hose shank) and lock the ball into the socket.

#### Step #4

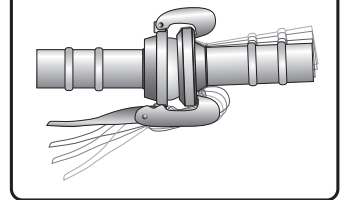

### A- Style Assembly Procedure

#### Step 1:

Insert the ball into the socket so that the ball seats loosely against the O-ring inside the socket.

#### Step #1

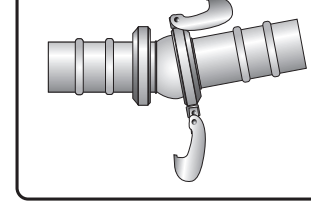

#### Step 2:

Reach around the locking ring with the "short" locking jaw and seat its gripping edge securely into the grooved lip on the back side of the locking ring.

#### Step #2

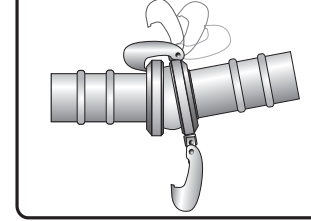

#### Step 3:

While keeping tension on the "short" locking jaw so that it remains in place, extend the "long" locking jaw forward to reach behind the locking ring and seat the gripping edge securely into the grooved lip.

#### Step #3

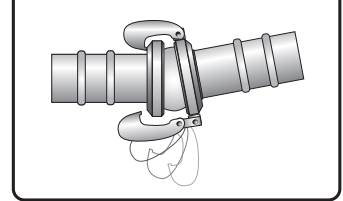

#### Step 4\*:

Finally, ensure that the leading edge of the ball is aligned just enough so that it does not cut into the O-ring surface, then (with 12" fittings) insert the leverage bar into the hole provided on the base of the "long" jaw and pull back toward the barbed shank to lock the ball into the socket.

#### Step #4

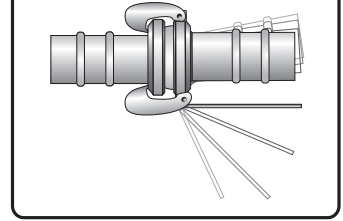

**\*NOTE:** 10" A-Style Wil-loc female/socket fittings have lever locking handles permanently attached to the "long" jaw mechanism. Locking action is similar to the B-Style lever arm.

**For additional information about the assembly or use of Wil-loc® Quick Coupling products, contact customer service at 1-800-801-0123.**