

Mechanical Belt Fastener Advantages

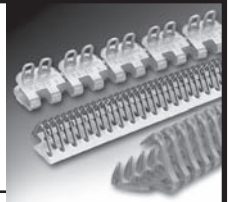

Repair mechanical belt splices in minutes, unlike vulcanized splices which can take hours or days.



Easy Installation

It's impossible to claim that vulcanization offers any advantage over mechanical fasteners in terms of easy installation. Mechanical fasteners can be installed on-site and typically only requires one installer with basic technical skills. Vulcanization is a long, involved process that often requires trained outside contractors who may have to do the job off-site.

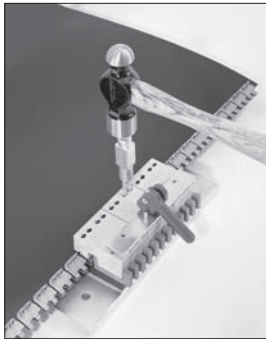

Quick Installation

Depending on the belt width and fastener selected, a belt can respliced with a reliable belt fastener from Flexco in approximately 20 minutes. Vulcanization can take hours or even days. Quicker installation means less downtime and greater productivity.

Economically Smart

It is less expensive to install a mechanical belt splice than a vulcanized splice.

Remove Belts Easily

Hinge pins can be removed from mechanical splices, allowing the belt to be separated for easy cleaning, installation and removal. This advantage isn't offered by vulcanization.

Proactive Maintenance

Because a mechanical splice is visible, any wear or deterioration is immediately apparent. Replacement or repairs can be scheduled during brief periods of downtime or at the end of a shift. A deteriorating vulcanized splice, in comparison, is not easily detected. Catastrophic line failure can be the first indication of trouble once adhesion breakdown occurs inside a vulcanized splice.

Mechanical Fastener Systems from Flexco

Flexco is undeniably the leader in mechanical belt fastener systems. Additional information regarding time-proven products such as Clipper® and Alligator® fastener systems can be found on the back of this brochure.



Flexco®

Mechanical Fastener Solutions from Flexco

Clipper® Wire Hook System

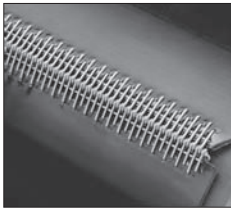

Clipper® hooks produce a low-profile, economical splice. What sets the Clipper splice apart is that the splice is machine applied for consistency and ease of installation. Clipper offers a variety of lacers available for on-site maintenance repairs, production lacing or for other special application needs. Clipper hooks are designed for belts up to 13/32" (10mm) and are available in a wide array of sizes, configurations and metal types.

Alligator® Ready Set™ Staple Fastener System



The Alligator® Ready Set™ Staple Fastener system is a strong and abrasion resistant splice. Installation is simple: Fit the Ready Set fastener strip onto the belt end, insert into the special installation tool, and drive the staples with a hammer for a strong, dependable splice. Ready Set fasteners are designed for belts from 1/16" (1.5mm) to 1/4" (6.4mm) thick.

Alligator® Belt Lacing Fastener System

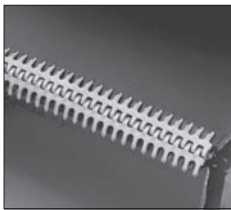

Alligator® Belt Lacing is a hammer applied splice that does not require any special installation tools. Ideal for low-volume users and designed for belts up to 1/2" (13mm) thick. Alligator lacing is available in continuous lengths to fit any belt width.

Alligator® Plastic Rivet Fastener System



For applications where metal fasteners can't be used, the Alligator® Plastic Rivet splice is a non-metallic splice that can be installed on-site with simple installation tools. Alligator Plastic Rivet allows the user to enjoy the advantages of both a mechanical splice and a non-metallic splice (non-abrasive, non-marking, FDA accepted). Designed for belts up to 1/8" (3.2mm).



Flexible Steel Lacing Company
2525 Wisconsin Avenue
Downers Grove, IL 60515-4200 U.S.A.
Telephone: (630)-971-0150
Fax: (630)-971-1180
E-mail: advertising@flexco.com
Visit our Web site at: www.flexco.com

Australia: 61-2-9680-3322 • England: 44-1457-891000 • Germany: 49-7428-9406-0 • Mexico: 52 55 56-74-53-26
New Zealand: 64-9-415-4488 • Republic of South Africa: 27-11-974-2771

©2002 Flexible Steel Lacing Company Lit Code 1888

Clipper® and Alligator® are registered trademarks and Ready Set™ is a trademark of Flexible Steel Lacing Company.



GOODYEAR
RUBBER PRODUCTS INC.

Call Toll Free: **1-866-711-4673**
WebSales@GoodyearRubberProducts.com

**We Ship
World Wide**

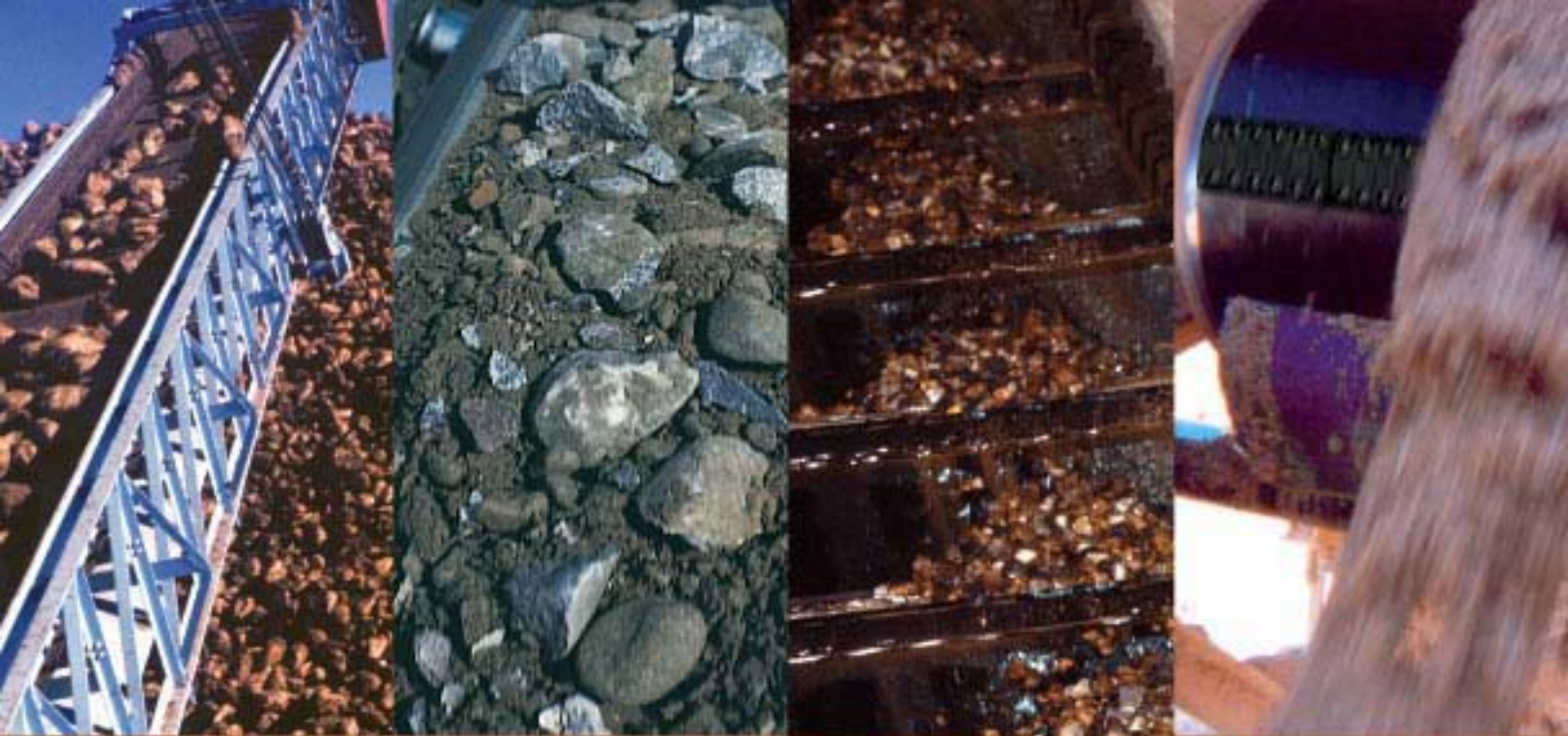

F A S T E R . E A S I E R . S A F E R .
S M A R T E R .

FLEXCO

Belt Conveyor Solutions for

**Aggregate
Applications**

GOODYEAR
RUBBER PRODUCTS INC.

Call Toll Free: **1-866-711-4673**

WebSales@GoodyearRubberProducts.com

**We Ship
World Wide**

"Flexco mechanical belt fasteners
are so easy and dependable,
they're pure genius."

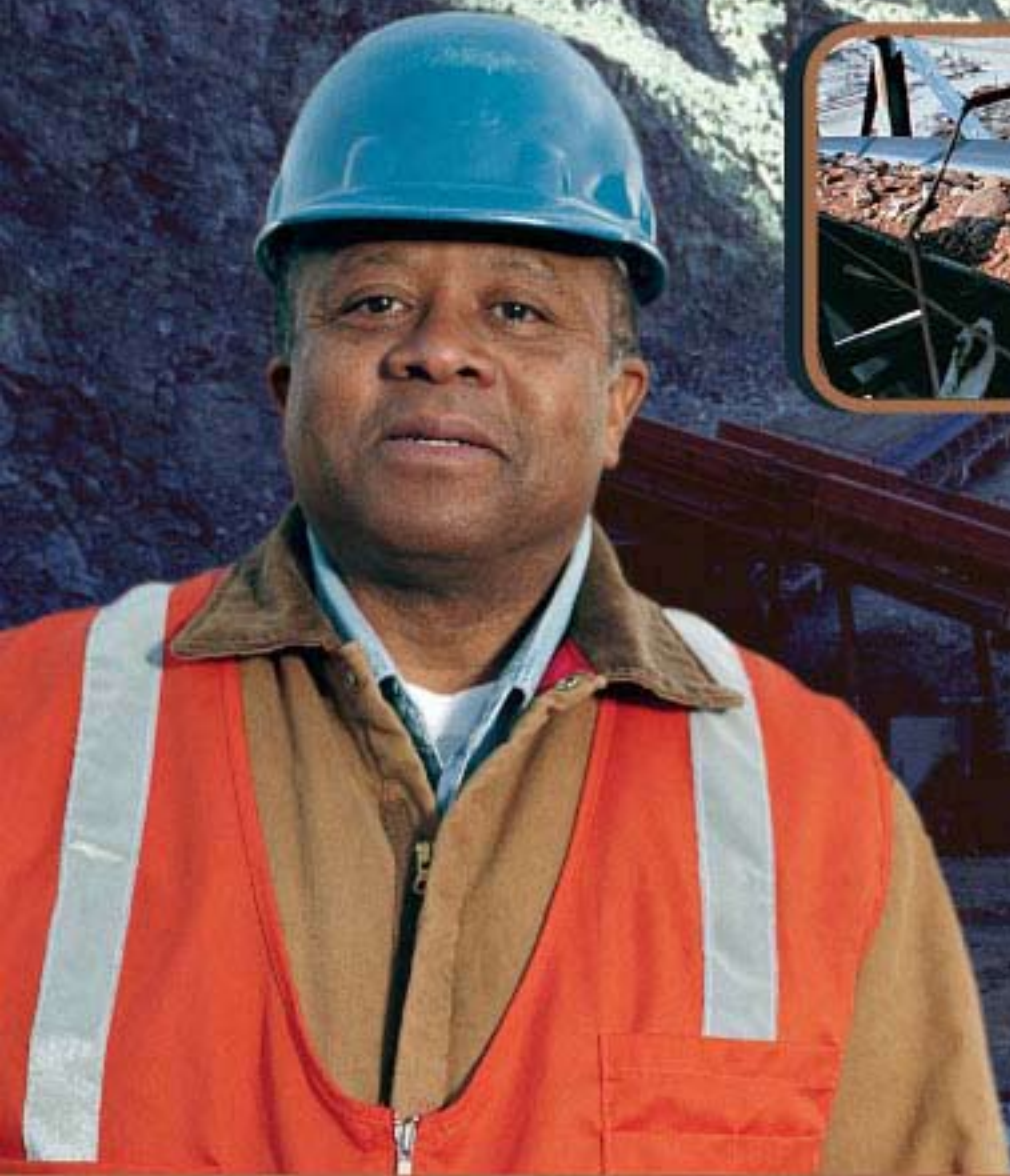

SMARTER.

With a strong, durable splice and faster installation, mechanical belt fasteners get you up and running and keep you running with less cost.

GOODYEAR
RUBBER PRODUCTS INC.

Call Toll Free: **1-866-711-4673**
WebSales@GoodyearRubberProducts.com

**We Ship
World Wide**

Flexco Advantage:

Mechanical belt fasteners simplify belt conveyor maintenance and can be installed faster and easier than vulcanized splices.



Quick Installation

- Most mechanical splices can be installed in less than an hour.
- In aggregate applications, vulcanized splices can take eight hours or more.



Simple Installation Tooling

- Using simple, portable installation tools your own maintenance crews can install mechanical belt fasteners.
- Vulcanization requires specially trained people—usually not your own employees.



Easy Inspection

- Generally with mechanical belt fasteners, wear can be seen before failures happen.
- Vulcanized splice breaks typically start within the belt causing catastrophic failures.



◀ Flexco FACTS

Flexco works closely with belt manufacturers to design fasteners that work effectively with the latest belt technology. The strength of Flexco® Bolt Solid Plate fasteners results from the compression of the plates that distributes the splice tension across the full width of each fastener plate. Specially formed teeth on each plate provide additional strength and resistance to pull-out.

"Moving thousands of tons of aggregate materials every day
requires a heavy-duty
fastening system that's tough."



STRONGER.

Installing the right mechanical belt fastener ensures an incredibly strong, permanent splice that exceeds most belt manufacturers' mechanical fastener specifications.

GOODYEAR
RUBBER PRODUCTS INC.

Call Toll Free: **1-866-711-4673**
WebSales@GoodyearRubberProducts.com

**We Ship
World Wide**

Flexco Advantage:

Flexco uses high-quality metals with consistent grades for all of our fastener products.

Flexco® VP™ Rubber Covered Fasteners

- Provide increased impact protection of top plates and reduced plate exposure to wear, resulting in longer splice life.
- Ideal for use with cleaners and highly abrasive materials.



Flexco® Bolt Fastener Systems

- The industry standard when it comes to meeting the demands of the toughest material-handling applications.
- Installation can be done on-site using portable hand or power tools.



Flexco® Rivet Fastener Systems

- Recommended for the most demanding high-tension applications.
- The staggered, multiple-point rivet attachments deliver long-lasting holding ability.
- Ideal for use with straight-warp belting.

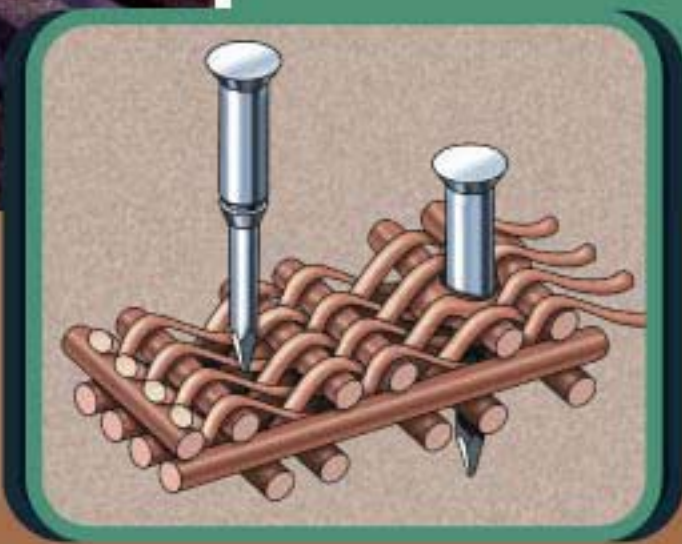

◀ Flexco FACTS

The Flexco® BR™ Rivet Solid Plate Fastener System is specifically designed for straight-warp carcass belting. The staggered, multi-point attachments penetrate between carcass fibers without severing them, delivering long-lasting holding ability.

Flexco Advantage:

Faster installation means increased productivity.

Simplified Installation

- Flexco® Quick Fit™ Pre-Assemblies have “moveable” mounting bolts that are pre-assembled into the bottom plate to simplify handling and positioning beneath the belt for faster installation.
- Self-adjusting, piloted bolts cradle nuts securely in place, eliminating the need to twist nuts onto bolts by hand to keep them in place.



Get Up And Running Fast

- Mechanical belt fasteners can be installed quickly on-site with our easy-to-use hand and power tools.
- Installation and maintenance typically requires no specialized training.



Faster, Smoother, Sift-Free Splices

- Exaggerated bolt hole spacing in the installation templet helps create a tight splice that prevents sifting by forcing the squared belt ends together.
- Flexco-Lok® belt tape allows for a smooth splice and added sifting prevention.



Flexco FACTS ▶

Flex-Lag® Pulley Lagging comes in easy-to-install strips for faster installation on-site. Eliminates high waste factor encountered with conventional sheet material lagging. Flex-Lag products are available in both rubber for standard applications and ceramic styles for increased water shedding capabilities and traction.



"Flexco Heavy-Duty Fastener solutions help

maximise our uptime
and productivity."



FASTER.

Flexco Safe™ maintenance and installation tools and improved fastener designs help make repairs on conveyor systems faster and simpler.

GOODYEAR
RUBBER PRODUCTS INC.

Call Toll Free: **1-866-711-4673**

WebSales@GoodyearRubberProducts.com

**We Ship
World Wide**

“Easy installation
is the reason we switched to Flexco.”

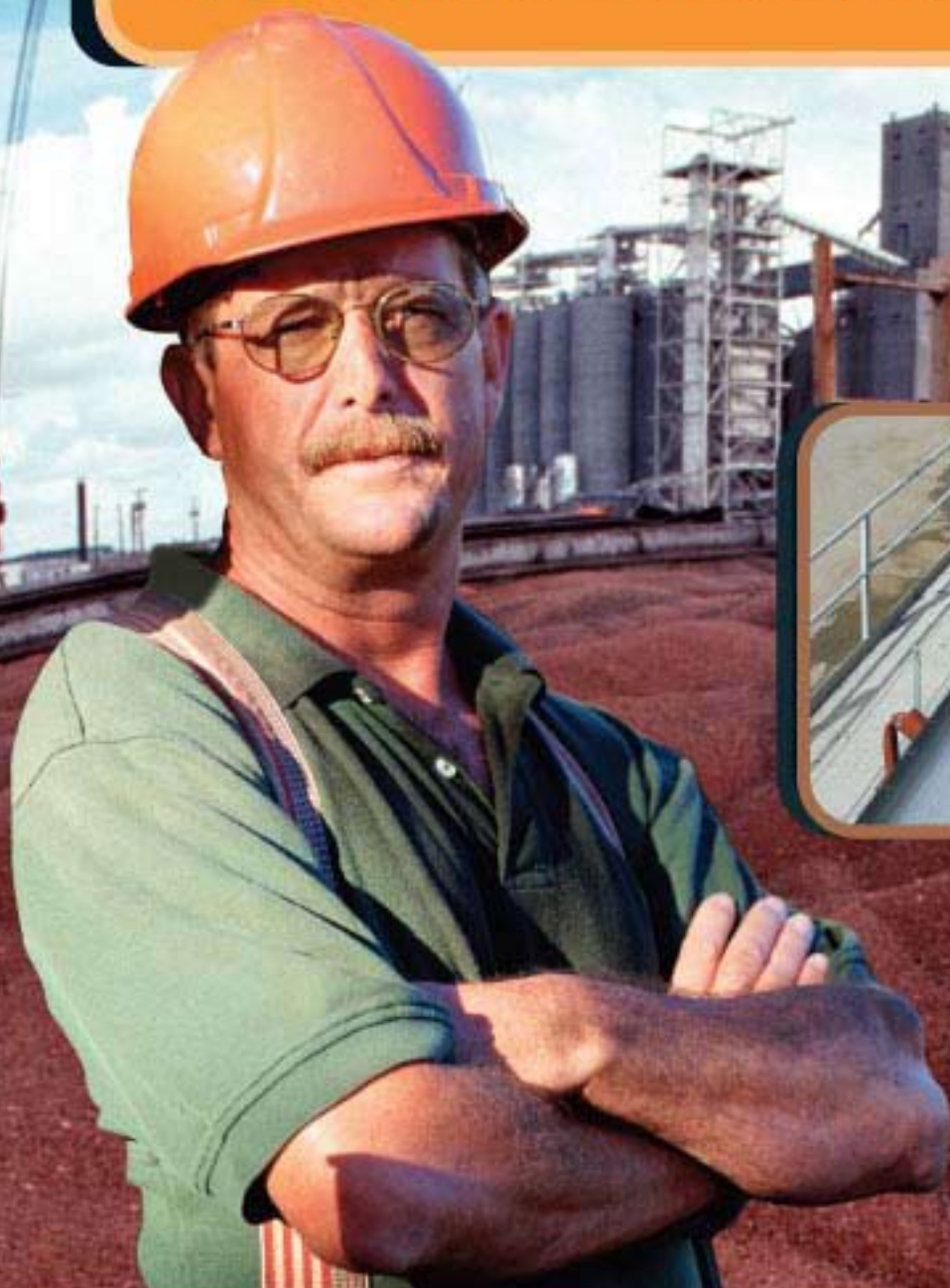

EASIER.

Flexco's innovative fastener designs, belt cleaners and specialized tools for the aggregate industry minimize downtime and make on-site installation easy.

GOODYEAR
RUBBER PRODUCTS INC.

Call Toll Free: **1-866-711-4673**
WebSales@GoodyearRubberProducts.com

**We Ship
World Wide**

Flexco Advantage:

Mechanical belt fasteners and cleaners keep belt lines up and running to help maximise job productivity.

On-Site Installation

- Because a mechanical splice is visible, any wear or deterioration is apparent immediately. This allows maintenance crews to proactively repair belts during scheduled downtime.
- Installation is quick and easy, and requires only portable hand tools. Power tools can be used along with the Flexco® Quick Change Chuck and an impact tool.
- Mechanical belt fasteners, belt positioners and skirt clamps are designed for simple installation and only require basic mechanical skills.



Easy On-Site Maintenance

- Flexco Safe™ installation tools are used directly on the belt conveyor.
- Rockline® RBP1 Belt Positioner™ correctly "positions" return side belts for an immediate, permanent solution for mistracking belts.
- Rockline® RDP1 Diagonal Plow is easily installed on a 45° angle across the belt to discharge debris to one side of the belt.

ROCKLINE



◀ Flexco FACTS

The Rockline® EZP1 Precleaner comes complete with everything you need for quick and easy installation, plus a quick-change blade for fast and easy blade replacement. A marking template and a pole location gauge help make sure the cleaner is installed in the right position to do the job you need.

Flexco Advantage:

Flexco provides both tools and training to make belt conveyor maintenance as safe as possible.

Safety Training

- Installation guides, on-site training, and web-based safety task training at www.flexcosafe.com provide comprehensive information on safe procedures for belt conveyor maintenance.



Flexco Safe™ Tools

- **840 Series Belt Cutter:**
Chain-driven, double-edged safety blade is shielded from operator contact and cuts rubber or PVC belts up to 25mm (1") thick.
- **Far-Pul® HD® Belt Clamps:**
Easy to use, lightweight and sturdy. Specifically engineered for heavy-duty applications.
- **Flex-Lifter™ Conveyor Belt Lifter:**
Durable and lightweight Flex-Lifter can safely lift a fully loaded belt. Use with flat or troughed belts without damaging belts.



Flexco FACTS ▶

The FSK™ Belt Skiver adjusts easily and precisely to various cutting depths to help prevent damage to the belt carcass. Easy to carry and operate around the job site—even in cramped operating environments.



“Safety is job one.

That’s why we use Flexco products exclusively.”

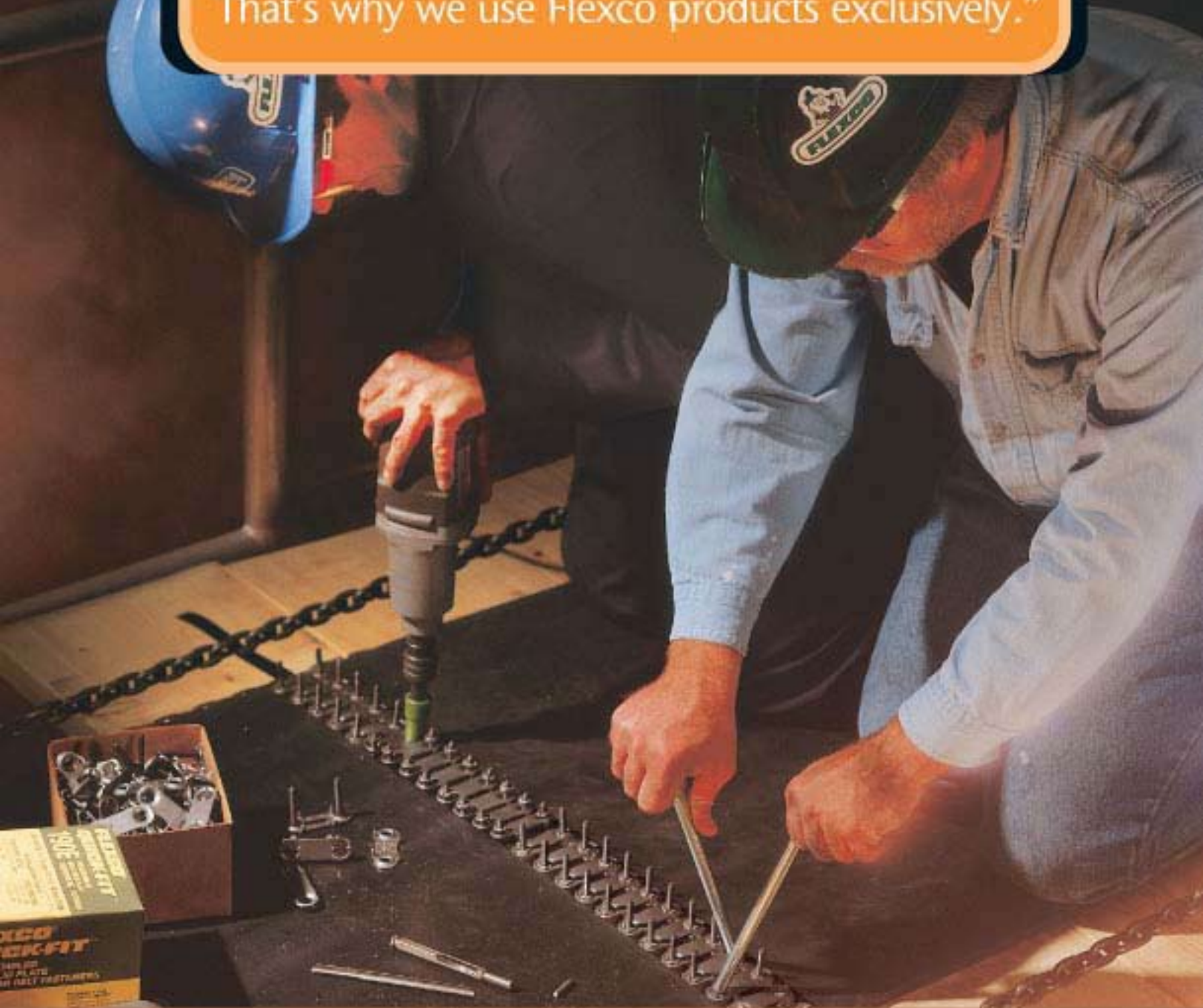

SAFER.

Flexco offers a wide assortment of installation and application tools designed with the safety of the operator in mind.

GOODYEAR
RUBBER PRODUCTS INC.

Call Toll Free: 1-866-711-4673

WebSales@GoodyearRubberProducts.com

**We Ship
World Wide**

Flexco Advantage:

Flexco designs and manufactures a complete line of fastener-friendly belt cleaners for the aggregate industry including precleaners and secondary cleaners.

Rockline® EZP1 Precleaner

ROCKLINE

- Features a unique uni-blade design that combines simple, do-it-yourself installation, quick maintenance and effective cleaning results.
- Visual blade tension check to assure optimal blade-to-belt tension at all times.



Rockline® EZS2 Secondary Cleaner

- FormFlex™ cushions automatically adjust the individual tension of each blade to the belt.
- Each individual cushion is independently tensioned so, as the blade wears, the cushion continues to power the blade to the belt—regardless of the wear rate on adjacent blades.
- Mounts easily on any conveyor structure.



Rockline® ConShear™ Replacement Blades

- The patented, faceted profile design allows the blade to renew its cleaning edge as it wears.
- Molded-in wear line indicates when the blade is worn and needs replacing.
- ConShear™ blades are made from a specially formulated urethane for superior abrasion resistance. Independent tests show a 25% to 30% longer wear life than other urethane blades.



Flexco FACTS ▶

Rockline® cleaning systems are specifically designed to work together with Flexco mechanical splices. The independently tensioned cushions allow the cleaning tips to move away and glide over the splice without damage and with minimal cleaning disruption.



GOODYEAR
RUBBER PRODUCTS INC.

Call Toll Free: **1-866-711-4673**

WebSales@GoodyearRubberProducts.com

**We Ship
World Wide**

"Finally, a durable cleaning system
that works effectively with
my mechanical fasteners."



CLEANER.

Simple installation, quick maintenance and effective cleaning results make Rockline® the preferred choice.

GOODYEAR
RUBBER PRODUCTS INC.

Call Toll Free: **1-866-711-4673**

WebSales@GoodyearRubberProducts.com

**We Ship
World Wide**

Choosing the right fastener for your needs.

Flexco offers a wide variety of mechanical belt fastener systems for Aggregate applications based upon specific needs. To select the recommended system that's right for your application, refer to the chart below.

Your Need	Our Recommendation	Other Smart Options
Ease of Installation	 <p>Quick-Fit™ Bolt Solid Plate Fasteners can be installed on-site using portable hand or power tools.</p>	Bolt Hinged VP Vulcanized Plate
Impact Resistance of Splice	 <p>VP™ Vulcanized Plate Rubber Covered Fasteners provide increased impact protection of top plates and reduced plate exposure to wear.</p>	Bolt Solid Plate BR Rivet Solid Plate
Abrasion Resistance	 <p>Quick-Fit™ Bolt Solid Plate Fasteners commonly used on belts conveying highly abrasive materials.</p>	VP Vulcanized Plate BR Rivet Solid Plate
Fastener/Cleaner Compatibility	 <p>VP™ Vulcanized Plate Rubber Covered Fasteners compatible with Rockline® belt cleaners.</p>	Bolt Solid Plate BR Rivet Solid Plate

Flexco®, Rockline®, Flex-Lag®, Flex-Pin®, HD® and Flexco-Lok® are registered trademarks.

GOODYEAR
RUBBER PRODUCTS INC.

Call Toll Free: 1-866-711-4673
WebSales@GoodyearRubberProducts.com

**We Ship
World Wide**

Your Need

Our Recommendation

Other Smart Options

Overall Strength of Splice



BR™ Rivet Solid Plate Fasteners staggered, multiple-point attachment delivers long-lasting holding ability.

Bolt Solid Plate
SR Rivet Hinged

Inexpensive Splice



Quick-Fit™ Bolt Solid Plate Fasteners a strong, sift-free splice with superior holding ability.

Bolt Hinged
VP Vulcanized Plate

Higher Tension Splice



BR™ Rivet Solid Plate Fasteners recommended for the most demanding high-tension applications.

SR Rivet Hinged
Bolt Solid Plate

Non-Magnetic



Quick-Fit™ Everdur Bolt Solid Plate Fasteners spark-free, long-wearing, non-magnetic. Used on belts employing magnetic pulleys and separators.

Bolt Hinged
VP Vulcanized Plate

Small Pulley Diameter



SR™ Rivet Hinged Fasteners
Bolt Hinged Fasteners ideal for belt conveyors with smaller pulley diameters.



◀ Flexco FACTS

Flexco offers a wide variety of mechanical belt fastener systems so you can select the one that is best suited for your needs. Additional selection information can be easily found at www.flexco.com.

- *Less downtime*
- *Easier to install*
- *Greater safety*
- *Reduced maintenance costs*
- *Increased productivity*

F A S T E R . E A S I E R . S A F E R .
S M A R T E R .



www.flexco.com

FLEXIBLE STEEL LACING COMPANY
2525 Wisconsin Avenue, Downers Grove, Illinois 60515
phone: +1 630-971-0150 fax: +1 630-971-1180 e-mail: info@flexco.com

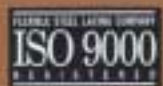

Australia: 61-2-9680-3322 • England: 44-1274-600-942 • Germany: 49-7428-9406-0
Mexico: 52 55 56-74-53-26 • Republic of South Africa: 27-11-974-2771

© 2006 Flexible Steel Lacing Company 10/05-1 For Reorder: Item Code X2060

GOODYEAR
RUBBER PRODUCTS INC.

Call Toll Free: 1-866-711-4673
WebSales@GoodyearRubberProducts.com

**We Ship
World Wide**



FASTER. EASIER. STRONGER.
SMARTER.

FLEXCO

***Belt Conveyor Solutions for
Agricultural
Harvesting & Processing***

GOODYEAR
RUBBER PRODUCTS INC.

Call Toll Free: **1-866-711-4673**

WebSales@GoodyearRubberProducts.com

**We Ship
World Wide**

"The smartest decision we ever made was
switching to Flexco
mechanical fastener systems."

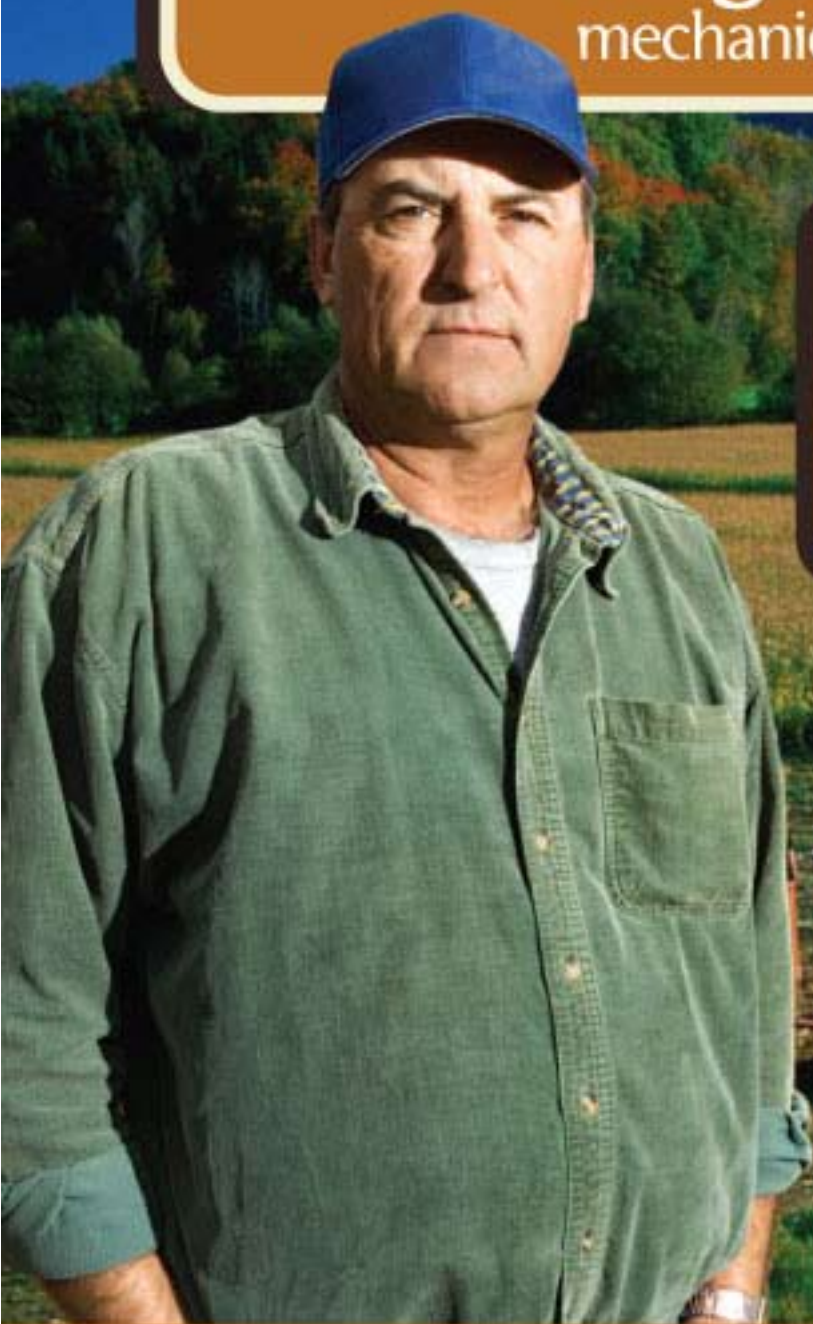

SMARTER.

Replacing a splice during the middle of a harvest can be costly. Flexco mechanical belt fasteners reduce installation time, creating a strong, dependable splice that resists wear and abrasion, getting you up and running fast.

GOODYEAR
RUBBER PRODUCTS INC.

Call Toll Free: **1-866-711-4673**

WebSales@GoodyearRubberProducts.com

www.flexco.com

**We Ship
World Wide**

Flexco Advantage:

When it comes to belt conveyor repairs for Agricultural applications, mechanical fasteners remain a clearly preferred alternative to vulcanization.

Faster.

- Quick, on-site and field installation in thirty minutes or less.
- Fast repairs mean less downtime, getting you back to harvesting and processing.

Easier.

- Installation tools are designed for simple procedures requiring only basic mechanical skills.
- Because Flexco mechanical splices are visible, wear-and-tear is easily monitored, so you can schedule repairs when it's convenient.

Stronger.

- Mechanical belt fasteners combine carcass penetration and compression to grip and hold belts securely for long-lasting operation.
- Fasteners are tested and rated with a 4:1 service factor so that selection can be optimized and peak loads handled.



Flexco FACTS

Flexco offers a wide variety of mechanical belt fastener systems, so you can select the one best suited for your needs. Additional selection information can be easily accessed at www.flexco.com.

Agricultural belt conveyor systems from Flexco:



Clipper® Wire Hooks

- A low profile yet exceedingly strong splice produces minimal wear on conveyor components. Just as important, Clipper® Wire Hooks reduce damage to delicate produce.
- An average 36" (900 mm) belt can be spliced on-site in less than 15 minutes using our Roller Lacer® installation tool, making this fastener system ideal for even the most time-sensitive harvests.



Alligator® Staple Fasteners

- This is the ultimate fastener system for applications requiring high-strength, abrasion-resistant splices.
- Pre-staked Ready Set™ staples use a simple installation method so splices can be installed with little training and effort.



Tatch-A-Cleat®

Belt Cleats, Pegs, Lugs and V-Guides

- Designed for a variety of conveyor operations, Tatch-A-Cleat® products help maximize carrying capacity, prevent material rollback, and can accommodate specialized counting and sorting. Ideal for outdoor harvesting and food processing.
- Available with fully rounded tops, designed to minimize bruising or marking of produce.



Choosing the right solution for your needs.

Flexco offers a wide variety of Agricultural belt conveyor solutions based upon specific needs. To select the product that's right for your application, refer to the chart below.

Your Need

Our Recommendation

- High Abrasion Resistant Splice
- High Strength Splice
- Easy Installation



Alligator
Alligator®
Staple Fasteners

- Quick Splice Installation
- Low Profile Splice
- Inexpensive Splice



Clipper
Clipper®
Wire Hook Fasteners

- Elevate Product Up Inclines
- Accommodate Special Sorting & Cleaning Requirements
- Easy, On-Site Installation with Common Hand Tools



TATCH-A-CLEAT.
Mechanical
Tatch-A-Cleat®
Offerings

- FDA Accepted Material
- Compatible with X-Ray Equipment



Alligator
Alligator®
Non-Metallic
Fastening Systems

- *Less downtime*
- *Easier to install*
- *Greater safety*
- *Reduced maintenance costs*
- *Increased productivity*

F A S T E R . E A S I E R . S T R O N G E R .
S M A R T E R .



www.flexco.com

FLEXIBLE STEEL LACING COMPANY
2525 Wisconsin Avenue, Downers Grove, Illinois 60515
phone: 630-971-0150 fax: 630-971-1180 e-mail: info@flexco.com

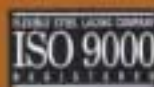

Australia: 61-2-9680-3322 • England: 44-1457-891000 • Germany: 49-7428-9406-0
Mexico: 52 55 56-74-53-26 • Republic of South Africa: 27-11-974-2771

© 2006 Flexible Steel Lacing Company 10/06-2.5-Part #X2066
Alligator, Dipper, Tatch-A-Deer, are registered trademarks of Flexible Steel Lacing Company

GOODYEAR
RUBBER PRODUCTS INC.

Call Toll Free: 1-866-711-4673
WebSales@GoodyearRubberProducts.com

**We Ship
World Wide**

Airport Baggage Handling Market

Airports use conveyor belts in a variety of ways to sort baggage and transport it to the final destination. In order to ensure baggage arrives with the passenger, it is important that the conveyor system is running optimally. Flexco, the world leader in belt fastening technology, offers a variety of belt fasteners to meet the demanding needs of the airport industry. Careful selection, installation, and preventative maintenance can significantly reduce belt splice costs and downtime.



Mechanical Fasteners Offer Advantages Over Vulcanization:

The growing trend in the international airport market is the shift away from vulcanized splices toward the greater operating efficiencies achieved with mechanical belt fasteners. Not only is the mechanical belt splice less expensive than a vulcanized splice, it can also save significant downtime costs.



Faster.

Quick Installation - A reliable belt splice can be installed in approximately 20 minutes. Vulcanized splices can take hours or days. Quicker installation means less downtime and greater productivity.

Easier.

Simple Installation - It is impossible to claim that vulcanization offers any advantage over mechanical fasteners in terms of easy installation. Mechanical fasteners can be installed on-site and typically require only one installer with basic technical skills and simple installation tools. Vulcanization is a long, involved process that often requires trained outside contractors who may have to do the job off-site.

Smarter.

Proactive Maintenance - Because a mechanical splice is visible, any wear or deterioration is immediately apparent. Replacement or repairs can be scheduled during brief periods of downtime or at the end of a shift. A deteriorating vulcanized splice, in comparison, is not easily detected. Catastrophic line failure can be the first indication of trouble once adhesion breakdown occurs inside a vulcanized splice.



Belt Fastening Solutions from Flexco

Global Customers Relying on Mechanical Belt Fastening Solutions from Flexco

- Chicago O'Hare Int'l Airport - USA
- Dubai Int'l Airport - United Arab Emirates
- Stuttgart Int'l Airport - Germany
- Bangkok Int'l Airport - Thailand
- Kuala Lumpur Int'l Airport - Malaysia
- Sydney Int'l Airport - Australia
- Los Angeles Int'l Airport - USA
- Tocumen Int'l Airport - Panama
- Melbourne International Airport - Australia
- Acropuerto Internacional El Dorado - Bogota, Columbia
- Zurich Int'l Airport - Switzerland
- Acropuerto Internacional Simon Bolivar - Caracas, Venezuela
- And Many More



Flexible Steel Lacing Company
2525 Wisconsin Avenue
Downers Grove, IL 60515-4200 U.S.A.
Telephone: (630)-971-0150
Fax: (630)-971-1180
E-mail: info@flexco.com



Clipper® Wire Hooks

Typical Applications: Check-In Conveyors,
Transport Baggage Systems

- This low-profile yet strong splice produces minimal wear on conveyor components and product being conveyed.
- An average 36" (900 mm) belt can be spliced on-site in less than 15 minutes using a Roller Lacer® installation tool, making this fastener system ideal for applications demanding quick installation/minimal downtime.



Alligator® Staple Fasteners

Typical Applications: Transport Baggage Systems,
Mobile Loading Conveyors

- Desired fastener system for demanding applications requiring a high strength, abrasion resistant splice.
- The pre-staked Ready Set™ staples and the simple installation method allows users to install the splices with little training and effort.



Alligator® Spiral Lace

Typical Applications: Security X-Ray
Scanning Belts

- Non-metallic splice will not interfere with scanning procedures.
- Low-profile, non-marking splice will not cause abrasion to luggage and conveyed product.



www.airport5.flexco.com

Australia: 61-2-9680-3322 • England: 44-1274-600-942 • Germany: 49-7428-9406-0 • Mexico: 52-5556-74-53-26 • Republic of South Africa: 27-11-971-2771

GOODYEAR
RUBBER PRODUCTS INC.

Call Toll Free: **1-866-711-4673**
WebSales@GoodyearRubberProducts.com

**We Ship
World Wide**

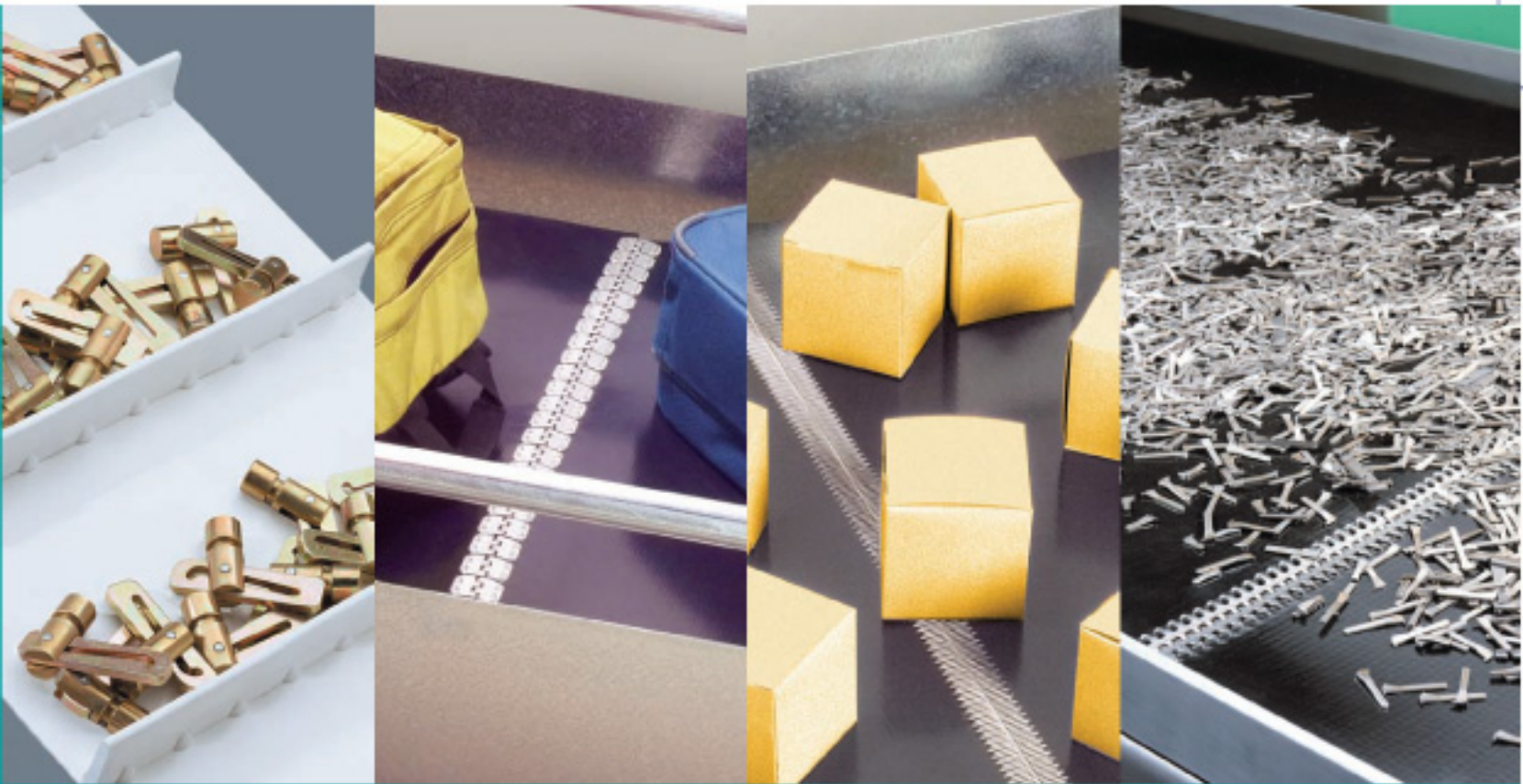

FASTER. EASIER. SAFER.
SMARTER.

FLEXCO



Belt Conveyor Solutions for
Package & Parts
Handling

GOODYEAR
RUBBER PRODUCTS INC.

Call Toll Free: **1-866-711-4673**
WebSales@GoodyearRubberProducts.com

**We Ship
World Wide**

“For a permanent,
dependable splice,
we switched to Flexco mechanical belt fasteners.”



SMARTER.

With a strong, durable splice and faster installation, mechanical belt fasteners significantly maximize uptime and increase productivity with less cost.

www.flexco.com

GOODYEAR
RUBBER PRODUCTS INC.

Call Toll Free: **1-866-711-4673**
WebSales@GoodyearRubberProducts.com

**We Ship
World Wide**

Flexco Advantage:

Mechanical belt fasteners simplify belt conveyor maintenance and can be installed faster and easier than vulcanized splices.



Quick Installation

- Most mechanical belt splices can be installed in 15-30 minutes.
- Compare that to vulcanized splices, where installation can take from four to six hours after a vulcanizing crew arrives.



Simple Installation Tooling

- Mechanical belt fasteners can be installed by your maintenance crew with simple, portable installation tools.
- Hot vulcanization requires large and heavy heating presses, plus special hand tools.



Easy Inspection

- With mechanical belt fasteners you can see wear before failures happen.
- In comparison, a vulcanized splice break cannot be predicted accurately.

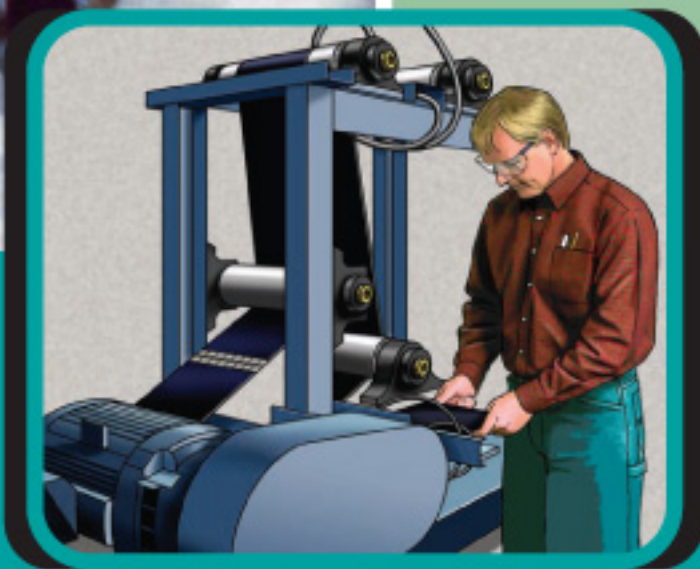

◀ Flexco FACTS

Nearly all of the belts used on package and parts handling conveyor systems are specifically designed to work with mechanical fasteners. Flexco engineers use sophisticated testing equipment to ensure that fasteners are designed to perform as permanent splices on these applications.

FLEXCO

GOODYEAR
RUBBER PRODUCTS INC.

Call Toll Free: **1-866-711-4673**
WebSales@GoodyearRubberProducts.com

**We Ship
World Wide**

“Moving tens of thousands
of pieces of luggage daily requires a
fastening system that’s tough.”



STRONGER.

Installing the right mechanical belt fastener ensures an incredibly strong, permanent splice that actually exceeds most application requirements.

www.flexco.com

GOODYEAR
RUBBER PRODUCTS INC.

Call Toll Free: **1-866-711-4673**
WebSales@GoodyearRubberProducts.com

**We Ship
World Wide**

Flexco Advantage:

Mechanical belt fasteners do not damage or weaken the belt carcass. Some vulcanization processes reduce the strength of the belt by 33% - 50%.



Alligator® Staple Fasteners



- Staples penetrate between carcass fibers without severing them. Staples are hammer-driven through the belt and then clinched crosswise to prevent belt tension from pulling against and unclenching the staples.



Clipper® Wire Hooks



- The double-staggered grip pattern gives wire hooks exceptional holding power without degrading the integrity of the belt carcass.
- The splice has a very low profile to protect products. It also makes the fastener more compatible with conveyor components.



◀ Flexco FACTS

Mechanical fasteners utilize a combination of carcass penetration and compression to grip and hold belts for secure and long lasting operation. Fasteners are tested and rated with a 4:1 service factor so that selection can be optimized and even peak loads can be handled.

FLEXCO

Flexco Advantage:

Faster installation means increased productivity.

- Mechanical belt fasteners can be installed on-site with minimal tooling by your own repair crews, while vulcanized splices are typically installed by outside firms, and can increase downtime by days.
- An average 36" (900mm) belt can be spliced in less than 15 minutes with Clipper® Wire Hooks using precise Roller Lacing Technology™.
- Alligator® Ready Set™ Staple Fasteners, featuring one-piece fastener strips with pre-inserted staples, significantly reduce installation time by eliminating the need to handle and load individual staples.



Flexco FACTS ▶

Tatch-A-Cleat® belt cleats, pegs, lugs and V-guides are specifically engineered to help increase productivity by allowing product to be conveyed at faster speeds and higher inclines. Easily attached with simple hand tools.



www.flexco.com

“Using Flexco’s Light-Duty Fasteners has substantially
cut our belt downtime.”



FASTER.

Flexco's improved fastener designs, installation tools and maintenance techniques result in faster, simpler repairs on your conveyor system.

FLEXCO

GOODYEAR
RUBBER PRODUCTS INC.

Call Toll Free: **1-866-711-4673**
WebSales@GoodyearRubberProducts.com

**We Ship
World Wide**

Flexco Advantage:

Mechanical belt fasteners not only get you up and running faster, they also help you maximize productivity and workplace safety.

On-Site Installation

- All installation tools are lightweight and have been designed to be used directly on the conveyor.

Simple Operation Steps

- Mechanical belt fasteners are designed for simple installation and only require basic mechanical skills.

Easy Maintenance

- Because a mechanical splice is visible, any wear or deterioration is immediately apparent, allowing the maintenance crew to proactively repair belts during scheduled downtime.



“Ease of install
and greater safety are the main
decided to switch to Flexco



EASIER.

Flexco has a wide selection of easy-to-install solutions to maximize productivity and performance throughout your conveyor line.

www.flexco.com

GOODYEAR
RUBBER PRODUCTS INC.

Call Toll Free: **1-866-711-4673**
WebSales@GoodyearRubberProducts.com

**We Ship
World Wide**

SAFER.

Flexco offers a wide assortment of installation and application tools designed with the safety of the operator in mind.

ation

reasons why we
mechanical fasteners."

Flexco Advantage:

Safety is job one.

That's why we provide both tools and training to make the fastener installation process as safe as possible.

Safety Training

- Installation manuals, on-site training and web-based safety task training (at www.flexco.com) provide comprehensive information on safe splicing techniques for mechanical fasteners.

Clipper® 845LD Belt Cutter

- This lacing accessory takes the dangerous job of cutting a conveyor belt and makes it extremely safe.
- The blade is fully enclosed, providing a cut that is not only straight and precise, but also quick and safe.

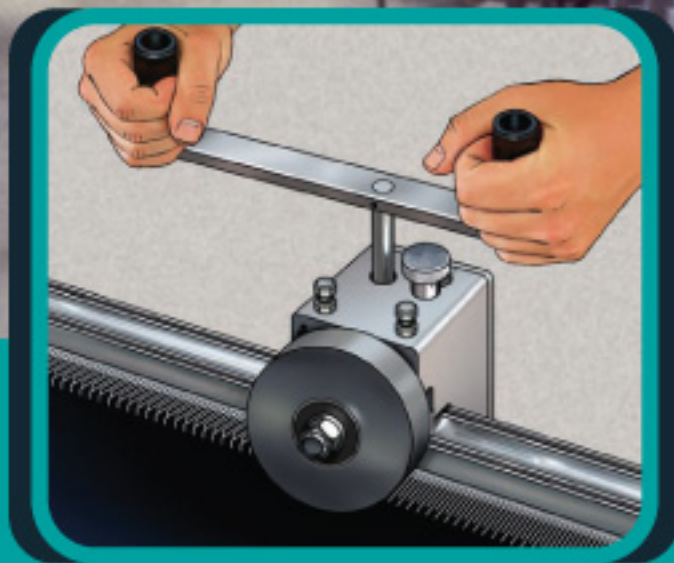

◀ Flexco FACTS

Mechanical belt fasteners can be installed with many of the tools you already have. Flexco also offers tools to help you do the job safer and easier.

FLEXCO

GOODYEAR
RUBBER PRODUCTS INC.



Call Toll Free: **1-866-711-4673**

WebSales@GoodyearRubberProducts.com

**We Ship
World Wide**

Choosing the right fastener for your needs.

Flexco offers a wide variety of mechanical belt fastener systems for Package and Parts Handling applications based upon specific needs. To select the recommended fastener system that's right for your application, refer to the chart below.

Your Need	Our Recommendation	Other Smart Options
Quick Installation - Minimum Downtime	 <p>Clipper® Wire Hooks offer the best solution for minimal downtime. The quick Roller Lacer Technology™ allows for a 60" (1500mm) splice to be installed in less than 30 minutes.</p>	Alligator Staple Fasteners Alligator Lacing
Abrasion Resistance of Splice	 <p>Alligator® Staple Fasteners provides superior abrasion resistance for demanding applications.</p>	Clipper Wire Hooks Alligator Lacing
Overall Strength of Splice	 <p>Alligator® Staple Fasteners can be safely operated in applications up to 200 PIW (35 kN/m).</p>	Clipper Wire Hooks Alligator Lacing
Inexpensive Splice	 <p>Clipper® Wire Hooks are economically priced.</p>	Alligator Lacing Alligator Staple Fasteners

Alligator®, Clipper®, Roller Lacer®, Tatch-A-Cleat® are registered trademarks.
Ready Set®, Roller Lacing Technology® are trademarks of Flexible Steel Lacing Company.

www.flexco.com

GOODYEAR
RUBBER PRODUCTS INC.

Call Toll Free: **1-866-711-4673**
WebSales@GoodyearRubberProducts.com

**We Ship
World Wide**

Your Need

Our Recommendation

Other Smart Options

Inexpensive Installation Tooling



Alligator® Lacing does not require any installation tool other than a hammer, making it ideal for low volume applications.

Alligator Staple Fasteners
Clipper Wire Hooks

Ease of Splice Installation



Alligator® Staple Fasteners splices are hammer-applied using a simple tool which guides and sets the staples.

Clipper Wire Hooks
Alligator Lacing

Low Profile Splice



Clipper® Wire Hooks create a low profile splice that produces minimal wear on conveyor components and the product being conveyed.

Alligator Lacing
Alligator Staple Fasteners

Non-Metallic, Non-Marking Splice



Alligator® Spiral Lace
Alligator® Plastic Rivet offer the advantages of hinged, mechanical belt splices with non-metallic properties. Ideal for applications involving food, x-ray equipment, or when conveying materials that are susceptible to scratching.



◀ **Flexco FACTS**

Flexco offers a wide variety of mechanical belt fastener systems, so you can select the one that is best suited for your needs. Additional selection information can be easily found at www.flexco.com.



- *Less downtime*
- *Easier to install*
- *Greater safety*
- *Reduced maintenance costs*
- *Increased productivity*

F A S T E R . E A S I E R . S A F E R .
S M A R T E R .



Authorized Distributor

www.flexco.com

FLEXIBLE STEEL LACING COMPANY
2525 Wisconsin Avenue, Downers Grove, Illinois 60515
phone: 630-971-0150 fax: 630-971-1180 e-mail: info@flexco.com

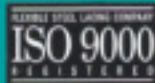

Australia: 61-2-9680-3322 • England: 44-1274-600-942 • Germany: 49-7428-9406-0
Mexico: 52 55 56-74-53-26 • Republic of South Africa: 27-11-974-2771

© 2006 Flexible Steel Lacing Company 2/06 For Reorder: Item Code X2037

GOODYEAR
RUBBER PRODUCTS INC.

Call Toll Free: **1-866-711-4673**
WebSales@GoodyearRubberProducts.com

**We Ship
World Wide**

The commercial laundry industry has relied on Clipper® wire hooks for decades, due to their ability to provide splices that are long-lasting and easy to install.

With thousands of sheets to dry, iron, and fold:

Depend on
Clipper® Fasteners
to keep your
operations moving.

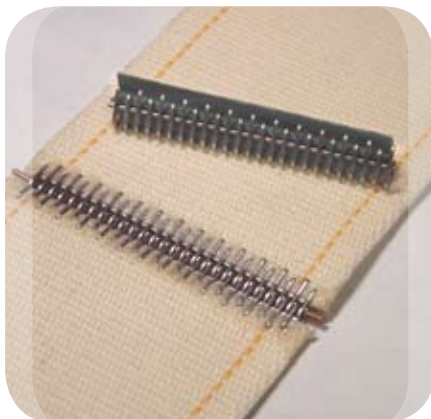
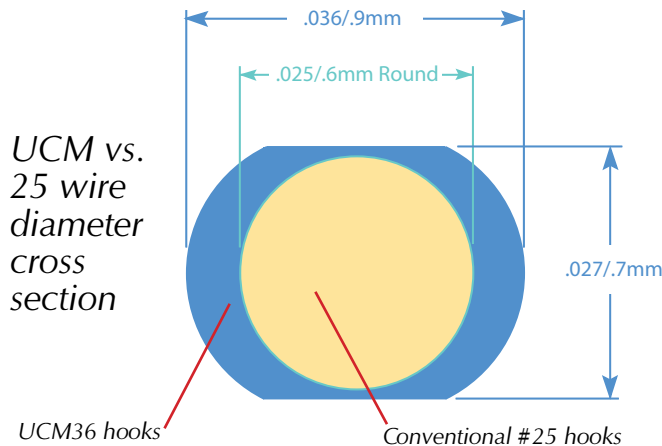

Faster.

A variety of installation equipment specifically designed for the commercial laundry industry allow facilities to quickly replace laundry tapes on-site, reducing downtime.

Stronger.

Clipper® UCM36 hooks offer greater strength and easier installation. Made from a shaped wire, .027" high x .036" wide (.7 x .9 mm), the UCM36 hooks provide greater strength and wire mass than #25 hooks, yet maintain a similar, low profile splice to the #25 splices.

Easier.

Individual hooks are welded to a common bar with the UCM36 hooks. This technology provides a sturdier splice which makes splice installation easier from all aspects: handling, removal of paper, meshing of ends together and pin insertion.

Smarter.

Flexco, a trusted leader in the industry, offers Clipper tools and accessories to simplify repairs and insure a dependable, long-lasting splice.

Belt Fastening Solutions from Flexco

Lacing Equipment

Pro-200 Electric Hydraulic Lacer:

Quickly and efficiently install low profile Clipper® splices. The lacer's durability, easy operating procedures and quick cycle time make this an ideal tool for high-volume, production lacing.



Vise Lacers:

An economical tool for installing Clipper splices. Fits in any shop vise.



#25 Lever Lacer:

Portable, extremely easy to use, hand-held installation tool for #25 hooks up to 2" (50 mm) wide.



LW95 Lacer:

A portable lacer which allows users to install up to 6" of lacing at a time, with the ability to continuous lace wider belts. Compatible with all sizes of Clipper hooks.



Fastener Ordering Information

Hook Size	Belt Thickness	Minimum Pulley Diameter	Custom Strip Length					
			1-7/8"	2"	2-1/2"	3"	3-1/2"	4"
UCM36SLXSP	Up to 1/16" (1.6mm)	15/16" (24mm)	02498	02496	02494	02492	02490	02488
UCM36SLSLP	1/16"-3/32" (1.6-2.4mm)	15/16" (24mm)	02497	02495	02493	02491	02489	02487
UCM36XSP	Up to 1/16" (1.6mm)	2" (51mm)	02043	02485	02483	02048	02042	02030
UCM36SP	1/16"-3/32" (1.6-2.4mm)	2" (51mm)	02486	02484	02407	02299	02041	02034

Ordering Information

Product	Ordering Number
Production Lacer	
Pro-200 Electric Hydraulic Lacer	PRO-200H
Pro-200 #25 Adapter	P2CLPR25
Pro-200 #36/30 Adapter	P2CLPR36/30
Pro-200 #1 Adapter	P2CLPR1
Vise Lacer	
#25 Vise Lacer	25VL-7
#36/30 Vise Lacer	36VL-7
#1 Vise Lacer	1VL-7
Lever Lacer	
#25 Lever Lacer	25LEVER
LW95 Lacer	
25XLW Lacer (#25 hooks)	25XLW
#1 Hook Retainer	HR1LW95
#36 Hook Retainer	HR36LW95
Tape Cutter	
#25 Tape Cutter	CUTTER-25
Tape Binder	
Non-flammable Tape Binder – Pint	BINDER-PT
Non-flammable Tape Binder – Quart	BINDER-QT
Non-flammable Tape Binder – Gallon	BINDER-GAL
Quick Dry Tape Binder – Quart	ODBINDER-QUART



2525 Wisconsin Avenue
Downers Grove, IL 60515-4200 U.S.A.
Telephone: (630)-971-0150
Fax: (630)-971-1180
E-mail: info@flexco.com



www.flexco.com

GOODYEAR
RUBBER PRODUCTS INC.

Call Toll Free: **1-866-711-4673**
WebSales@GoodyearRubberProducts.com

**We Ship
World Wide**

Alligator® Conveyor Belt Lacing Fastener System

AL200

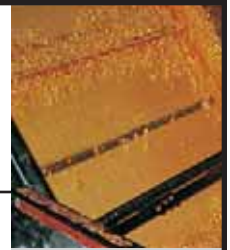

Alligator®



For easy, economical installation and an exceptionally smooth joint, choose the Alligator® Conveyor Belt Lacing System. Alligator Lacing is available in continuous lengths to fit any belt width and the one-piece design provides uniform tension across the full belt width. The one-piece fastener strip also ensures that there are no loose pieces to work themselves out of the belt and into the conveyed product.

Designed for belts from 1/32" (.8 mm) to 1/2" (12.5 mm), Alligator Belt Lacing installation requires no special tools, only a hammer. The lacing is secured with teeth that embed lengthwise on the belt, providing a strong, vise-like hold. Clips hold gauge rod and lacing firmly and squarely against the belt and ensures a strong, straight splice. The straight splice also helps ease hinge pin insertion.

Market applications

- Package/Parts Conveying
- Food/Sanitary Contact
- Agricultural Harvesting/Handling
- Recycling/Scrap Handling
- Wood Products

Alligator® Conveyor Belt Lacing Selection Chart

Lacing Size	For Belts With Mechanical Fastener Ratings Up To:		Belt Thickness Range		Recommended Minimum Pulley Diameter		Approx. Corrugated Hinge Pin Diameter		Strip Length	
	PLW	kN/m	in.	mm	in.	mm	in.	mm	in.	mm
00	25	4.3	Up thru 1/16	Up thru 1.6	1	25	3/64	1.2	6	152
1	45	7.8	1/16-3/32	1.6-2.4	1-1/2	38	1/16	1.6	6	152
7	50	8.7	3/32-9/64	2.4-3.6	2	51	1/16	1.6	6	152
15	65	11.4	1/8-5/32	3.2-4.0	2-1/2	64	3/32	2.4	12	305
20	95	16.6	5/32-3/16	4.0-4.8	3	76	7/64	2.8	12	305
25	100	17.5	3/16-7/32	4.8-5.6	4	102	1/8	3.2	12	305
27	100	17.5	7/32-9/32	5.6-7.1	5	127	1/8	3.2	12	305
35	150	26	9/32-5/16	7.1-7.9	7	178	9/64	3.6	12	305
45	165	28	5/16-3/8	7.9-9.5	9	229	3/16	4.8	12	305
55	175	30	3/8-7/16	9.5-11.1	12	305	13/64	5.2	12	305
65	200	35	7/16-1/2	11.1-12.7	14	356	13/64	5.2	12	305

Alligator® Conveyor Belt Lacing

Fasteners Alligator® Belt Lacing is available in steel or stainless steel.

Steel

Steel is the standard fastener material. It is suitable for most applications, and is plated for rust and corrosion resistance.

300 Series Stainless Steel

300 Series stainless steel is non-rusting and displays extra resistance to abrasion, acids, chemicals, and magnetic attraction. It is excellent in applications with high sanitation requirements.



Corrugated Hinge Pins

H – Corrugated

The corrugated pin is standard and is suitable for all sizes of Alligator Belt Lacing and for smaller transmission belt lacing applications. Lugs on the hinge pin engage lacing loops, reducing the possibility of hinge pin migration. Available in steel (H) or stainless steel (SH).



Steel Lacing with steel corrugated hinge pins

Carton contains 4 sets of lacing, 4 corrugated hinge pins, and 1 installation gauge pin with clips.

Belt Width		00	1A	7	15	20	25	27	35	45	55
in.	mm										
12	300	00-12	1A-12	7-12	15-12	20-12	25-12	27-12	35-12	45-12	55-12
18	450	00-18	1A-18	7-18	15-18	20-18	25-18	27-18	35-18	45-18	55-18
24	600	00-24	1A-24	7-24	15-24	20-24	25-24	27-24	35-24	45-24	55-24
30	750	00-30	1A-30	7-30	15-30	20-30	25-30	27-30	35-30	45-30	55-30
36	900	00-36	1A-36	7-36	15-36	20-36	25-36	27-36	35-36	45-36	55-36
42	1050	00-42	1A-42	7-42	15-42	20-42	25-42	27-42	35-42	45-42	55-42
48	1200	00-48	1A-48	7-48	15-48	20-48	25-48	27-48	35-48	45-48	55-48
60	1500	00-60	1A-60	7-60	15-60	20-60	25-60	27-60	35-60	45-60	55-60

Stainless Lacing with stainless corrugated hinge pins

Carton contains 4 sets of lacing, 4 corrugated hinge pins, and 1 installation gauge pin with clips.

Belt Width		00S	1S	7S	15S	20S	25S	27S	35S	45S
in.	mm									
12	300	00S-12	1S-12	7S-12	15S-12	20S-12	25S-12	27S-12	35S-12	45S-12
18	450	00S-18	1S-18	7S-18	15S-18	20S-18	25S-18	27S-18	35S-18	45S-18
24	600	00S-24	1S-24	7S-24	15S-24	20S-24	25S-24	27S-24	35S-24	45S-24
30	750	00S-30	1S-30	7S-30	15S-30	20S-30	25S-30	27S-30	35S-30	45S-30
36	900	00S-36	1S-36	7S-36	15S-36	20S-36	25S-36	27S-36	35S-36	45S-36
42	1050	00S-42	1S-42	7S-42	15S-42	20S-42	25S-42	27S-42	35S-42	45S-42
48	1200	00S-48	1S-48	7S-48	15S-48	20S-48	25S-48	27S-48	35S-48	45S-48
60	1500	00S-60	1S-60	7S-60	15S-60	20S-60	25S-60	27S-60	35S-60	

Alligator® Conveyor Belt Lacing

Transmission Belt Lacing

For flat power-transmission belts up to 12" (300 mm) wide, Alligator® Transmission Belt Lacing is available for sizes 00 through 65. Lacing is "scored" so it can be easily trimmed to fit narrower belts. Corrugated hinge pins are furnished with the three smallest lacing sizes. A two-piece Rocker Hinge pin is available for sizes 15 to 65.

Boxes contain 12" (300 mm) lacing strips (except Nos. 00 and 1 & 7 which contain 6" [150 mm] strips), hinge pins, and 1 gauge pin. Four or six joints per box.

Transmission Belt Lacing

Belt Width		Steel	300 Series Stainless
in.	mm		
6	150	00	00S
6	150	1A	1AS
6	150	7	7S
12	300	15	15S
12	300	20	20S
12	300	25D	25DS
12	300	27K	27KS
12	300	35N	35NS
12	300	45U	45US
12	300	55W	55WS
12	300	65X	



Rocker Hinge Pin

RH – Rocker

The Rocker Hinge pin is furnished with Transmission Belt Lacing. The two-piece pin provides rocking action to reduce friction and wear on loops and lacing. Sizes 15 through 65 are available in steel (RH) or stainless steel (SRH).



Alligator® Conveyor Belt Lacing

Clipper® 845LD Belt Cutter

The Clipper® 845LD aluminum belt cutter delivers the straightest cuts – time after time – in an easy-to use lightweight, corrosion-resistant package.

The chain-driven, double-edged safety blade can be driven from either end, cutting in a single pass. Cuts straight every time on rubber or PVC belts up to 1/2" (12 mm) thick. Plus, the aluminum frame makes the 845LD easy to carry and use.



Clipper® 845LD Belt Cutter

Belt widths up to:		Description	Ordering Number
in.	mm		
36	900	36" Belt Cutter	845836LD
48	1200	48" Belt Cutter	845848LD
60	1500	60" Belt Cutter	845860LD
72	1800	72" Belt Cutter	845872LD

Hand Skiver

Our hand-held skiver makes it easy to remove impression covers prior to fastener size selection and installation. Allows fasteners to be installed closer to the belt carcass for a lower profile.



Hand Skiver

Ordering Number
RTBS Rough Top Skiver

Belt Nippers

Notches belt ends quickly and easily to help avoid splice hang-up.



Belt Nippers

Ordering Number
BN-1

Australia: 61-2-9680-3322 • England: 44-1457-891000 • Germany: 49-7428-9406-0
Mexico: 52-55-5674-5326 • New Zealand: 64-9-415-4488 • Republic of South Africa: 27-11-974-2771

© 2003 Flexible Steel Lacing Company. 7/03, Part#X0728
Alligator® and Clipper® are registered trademarks of Flexible Steel Lacing Company.



Flexible Steel Lacing Company
2525 Wisconsin Avenue
Downers Grove, IL 60515-4200 U.S.A.
Telephone: (630) 971-0150
Fax: (630) 971-1180
E-mail: advertising@flexco.com
Visit our Web site at: www.flexco.com



GOODYEAR
RUBBER PRODUCTS INC.

Call Toll Free: 1-866-711-4673
WebSales@GoodyearRubberProducts.com

**We Ship
World Wide**

Alligator® Ready Set™ Staple Fastener System

AS200



The Alligator® Ready Set™ Staple Fastener System is ideal for a wide variety of light- and medium-duty fastener applications. The system features one-piece fastener strips with pre-inserted staples that speed installation and keep downtime to a minimum.

Quick, easy installation

Designed for belts from 1/16" (1.5 mm) to 1/4" (6.4 mm), Alligator Ready Set installation is easy with a portable, lightweight application tool that is easily carried to the job for on-site installation. Simply fit the fastener strip onto the belt end and secure with the special installation tool, then drive and finish set the staples for a strong, long-lasting splice.



Market applications

- Package/Parts Conveying
- Food/Sanitary Contact
- Agricultural Harvesting/Handling
- Recycling/Scrap Handling
- Wood Products

Alligator® Ready Set™

Alligator® Ready Set™ Staple Fastener Selection Guide

Fastener Size No.	For Belts With Mechanical Fastener Ratings Up To:		Belt Thickness Range		Recommended Minimum Pulley Diameter	
	P.I.W.	kN/m	in.	mm	in.	mm
RS62	100	17	1/16-1/8	1.5-3.2	2	50
RS125	160	28	1/8-3/16	3.2-4.8	3	75
RS187	200	35	3/16-1/4	4.8-6.4	4	102

Alligator® Ready Set™ Staple Fastener System

Fasteners

A variety of fastener sizes and metals are available for joining belts in a wide range of light- to medium-duty applications.

Steel

The standard fastener material; suitable for most applications.

Stainless Steel

300 Series stainless steel provides extra resistance to abrasion, magnetic attraction, and corrosion from acids and other chemicals.



Fasteners

(One carton contains 4 fastener sets, 4 hinge pins, and required amount of retaining washers.)

Belt Width		Steel With Nylon Covered Steel Cable Pins (NC)	Stainless (300 Series) With Stainless Spring Wire Pins (SS)	Stainless (300 Series) With Nylon Covered Stainless Cable Pins (NCS)
in.	mm			
RS62				
12	300	RS62J12/300NC	RS62SJ12/300SS	RS62SJ12/300NCS
18	450	RS62J18/450NC	RS62SJ18/450SS	RS62SJ18/450NCS
24	600	RS62J24/600NC	RS62SJ24/600SS	RS62SJ24/600NCS
30	750	RS62J30/750NC	RS62SJ30/750SS	RS62SJ30/750NCS
36	900	RS62J36/900NC	RS62SJ36/900SS	RS62SJ36/900NCS
42	1050	RS62J42NC	RS62SJ42SS	
48	1200	RS62J48NC	RS62SJ48SS	RS62SJ48NCS
60	1500	RS62J60NC	RS62SJ60SS	RS62SJ60NCS
RS125				
12	300	RS125J12/300NC	RS125SJ12/300SS	RS125SJ12/300NCS
18	450	RS125J18/450NC	RS125SJ18/450SS	RS125SJ18/450NCS
24	600	RS125J24/600NC	RS125SJ24/600SS	RS125SJ24/600NCS
30	750	RS125J30/750NC	RS125SJ30/750SS	RS125SJ30/750NCS
36	900	RS125J36/900NC	RS125SJ36/900SS	RS125SJ36/900NCS
42	1050	RS125J42NC	RS125SJ42SS	RS125SJ42NCS
48	1200	RS125J48NC	RS125SJ48SS	RS125SJ48NCS
60	1500	RS125J60NC	RS125SJ60SS	RS125SJ60NCS
RS187				
12	300	RS187J12/300NC	RS187SJ12/300SS	RS187SJ12/300NCS
18	450	RS187J18/450NC	RS187SJ18/450SS	RS187SJ18/450NCS
24	600	RS187J24/600NC	RS187SJ24/600SS	RS187SJ24/600NCS
30	750	RS187J30/750NC	RS187SJ30/750SS	RS187SJ30/750NCS
36	900	RS187J36/900NC	RS187SJ36/900SS	RS187SJ36/900NCS
42	1050	RS187J42NC	RS187SJ42SS	RS187SJ42NCS
48	1200	RS187J48NC	RS187SJ48SS	RS187SJ48NCS
60	1500	RS187J60NC	RS187SJ60SS	RS187SJ60NCS

Alligator® Ready Set™ Staple Fastener System

Hinge Pins

Match our selection of hinge pins to the special needs of your application.

NC - Nylon Covered Steel Cable

For use with steel fasteners, NC hinge pins are recommended for troughing or flat belt conveyors.

NCS - Nylon Covered Stainless Steel Cable

For extra resistance to abrasion.

SS - Stainless Steel Spring Wire

For use with stainless steel fasteners.



NC - Nylon Covered Steel Cable



NCS - Nylon Covered Stainless Steel Cable



SS - Stainless Steel Spring Wire

Hinge Pins

Pin material is offered in 10' (3 M) coils ("X") or 100' (30 M) reels ("C").

Packages of 10 pins.

Coil Length		NC Nylon Covered Steel Cable	NCS Nylon Covered Stainless Cable
Foot	M		
RS62			
10	3	NC62-X	NCS62-X
100	30	NC62-C	NCS62-C
RS125			
10	3	NC1-X	NCS1-X
100	30	NC1-C	NCS1-C
RS187			
10	3	NC187-X	NCS187-X
100	30	NC187-C	NCS187-C

Belt Width		SS 300 Series Stainless Spring Wire Pins
in.	mm	
RS62		
12	300	SS62-12/300
18	450	SS62-18/450
24	600	SS62-24/600
30	750	SS62-30/750
36	900	SS62-36/900
42	1050	SS62-42
48	1200	SS62-48
60	1500	SS62-60
RS125		
12	300	
18	450	SS1-18/450
24	600	SS1-24/600
30	750	SS1-30/750
36	900	SS1-36/900
42	1050	SS1-42
48	1200	SS1-48
60	1500	SS1-60
RS187		
12	300	
18	450	SS2-18/450
24	600	SS2-24/600
30	750	SS2-30/750
36	900	SS2-36/900
42	1050	SS2-42
48	1200	SS2-48
60	1500	SS2-60

Hinge Pin Retaining Washers

Eliminate problems associated with hinge-pin migration with easy-to-install retaining washers.

For Fastener Number	Ordering Number
62	62-RET-50
125	125-RET-50
187	187-RET-50

Box of 50 washers.

Alligator® Ready Set™ Staple Fastener System

RSC187 Installation Tool

Securely holds the fasteners on the belt, in proper alignment, while staples are driven. Installs two staples simultaneously for fast, simple splicing and the tool can be moved rapidly along the belt as staples are installed. Also provides an anvil surface for initial clinching of the staples.

The RSC187 tools come complete with guide blocks and drivers, and are available in a variety of sizes. Wider tools are available for production lacing and fabrication shop requirements.

RSC187 Installation Tool

Tool Size		Ordering Number
in.	mm	
2	50	RSC187
4	100	RSC187-4
6	150	RSC187-6
12	300	RSC187-12
24	600	RSC187-24

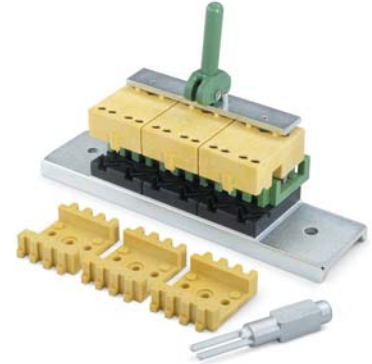

Staple Kits

Everything you need to install, maintain, and repair Alligator® Ready Set™ Staple splices. Kit includes the RSC187 tool described above, as well as the staple set plate, hand skiver, belt marker, belt nippers, and 1 lb. (.45 kg) hammer. Packaged in a durable box with plenty of room left over for other items.

Staple Kits

Description	Ordering Number
6" Installation Kit	RSTK4-6
12" Installation Kit	RSTK4-12



Hand Skiver

Our hand-held skiver makes it easy to remove impression covers prior to fastener size selection and installation. Allows fasteners to be installed closer to the belt carcass for a lower profile.

Hand Skiver

Ordering Number
RTBS Rough Top Skiver



Flexible Steel Lacing Company
 2525 Wisconsin Avenue
 Downers Grove, IL 60515-4200 U.S.A.
 Telephone: (630) 971-0150
 Fax: (630) 971-1180
 E-mail: advertising@flexco.com
 Visit our Web site at: www.flexco.com



Australia: 61-2-9680-3322 • England: 44-1457-891000 • Germany: 49-7428-9406-0
 Mexico: 52-55-5674-5326 • New Zealand: 64-9-415-4488 • Republic of South Africa: 27-11-974-2771

© 2003 Flexible Steel Lacing Company. 7/03, Part#X0727
 Ready Set™ is a trademark and Alligator® is a registered trademark of Flexible Steel Lacing Company

Alligator® Staple Gold Class™ Installation Tool



**Power Assisted Tool
Improves
Consistency
& Reduces
Installation
Time**



Faster.

The air operated power driver allows belt fabricators to install Alligator® Ready Set™ two plates at a time, with quick and effortless trigger pulls. This simple installation process allows for splices to be installed quickly and consistently, regardless of operator skill and experience.

Easier.

Not only is the installation process easy, it is virtually error-proof. The drive punch has been designed to seat the front edge of the fastener plate down for proper compression, while at the same time the fastener loops remain protected. With hammer installation, fastener loops can get crushed with accidental hammer blows, resulting in problems with pin insertion.

Safer.

By eliminating the need to hammer install the fasteners, the Alligator Staple Gold Class tool reduces the risk of repetitive motion injuries. It also reduces operator fatigue associated with hammer installing numerous splices throughout the day.

Smarter.

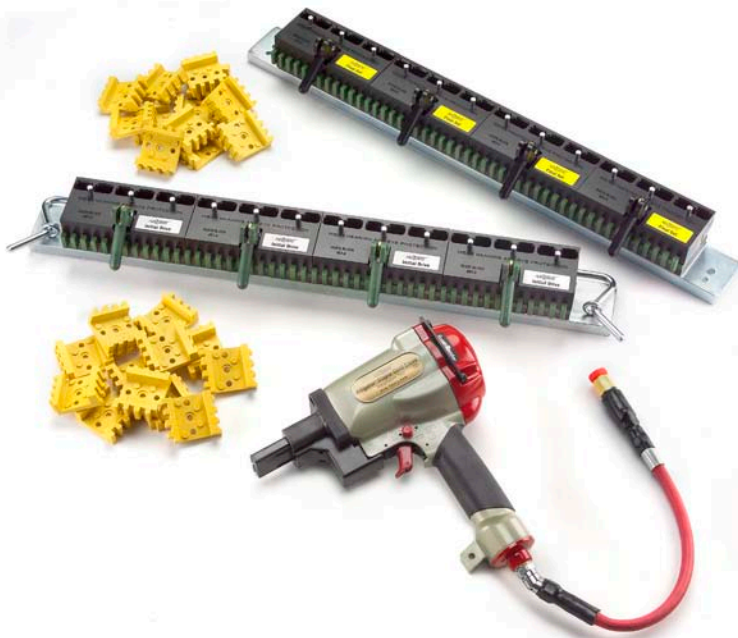

Alligator® Staple Gold Class™ from Flexco

Profiled front edge of the drive punch creates proper compression set of the front edge of the fastener plate.



Initial Drive Base: Fasteners and belt are inserted into this Initial Drive Base where the pre-staked staples are driven through the belt with simple trigger pulls.



Final Set Base: After the fasteners are initially set, move belt splice to the Final Set Base where the staples receive their final set and the compression fit is obtained.



Ordering Information		
Description	Item Code	Ordering Number
Alligator® Staple Gold Class™		
Power Driver	55541	RS-GOLD-DRIVER
Initial Drive Base		
6" Initial Drive Base	55542	RS-GOLD-INITIAL-6
12" Initial Drive Base	55543	RS-GOLD-INITIAL-12
24" Initial Drive Base	55544	RS-GOLD-INITIAL-24
36" Initial Drive Base	55548	RS-GOLD-INITIAL-36
48" Initial Drive Base	55551	RS-GOLD-INITIAL-48
Final Drive Base		
6" Final Set Drive Base	55545	RS-GOLD-FINAL-6
12" Final Set Drive Base	55546	RS-GOLD-FINAL-12
24" Final Set Drive Base	55547	RS-GOLD-FINAL-24
36" Final Set Drive Base	55549	RS-GOLD-FINAL-36
48" Final Set Drive Base	55552	RS-GOLD-FINAL-48
Replacement Parts		
Guide Block	55554	ST7-5
Punch	55555	ST7-9
Wear Plate (Final Set Base)	55556	ST7-29
Safety Guard	55561	ST7-34
Regulator Hose Assembly	55562	ST7-35



2525 Wisconsin Avenue
Downers Grove, IL 60515-4200 U.S.A.
Telephone: (630)-971-0150
Fax: (630)-971-1180
E-mail: info@flexco.com



www.flexco.com

GOODYEAR
RUBBER PRODUCTS INC.

Call Toll Free: **1-866-711-4673**
WebSales@GoodyearRubberProducts.com

**We Ship
World Wide**

Alligator® Rivet Fastening System

AR200A

Alligator® Rivet is a strong, easy-to-install splice for round hay baler applications.

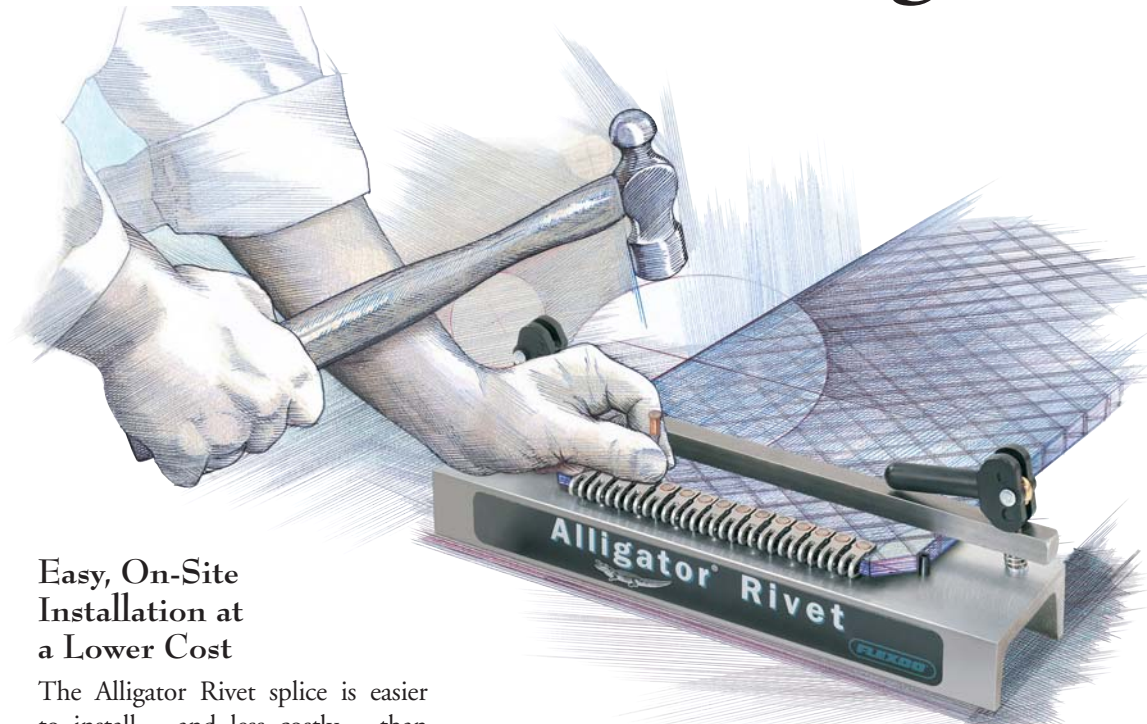

Easy, On-Site Installation at a Lower Cost

The Alligator Rivet splice is easier to install – and less costly – than other competitive brands. And, without ever removing the belts from the baler, field installation is quick and easy with only the portable application tool and a 1 lb. hammer.

High Strength and Longer Life

Rugged, stainless steel design is abrasion- and corrosion-resistant and has a long life for severe, heavy-duty applications.

Fasteners are available in 4", 6", 7", 10" and 14" (100 mm, 150 mm, 175 mm, 250 mm and 350 mm) pre-cut lengths, and can be cut to shorter lengths.

Self-setting rivets accommodate belts 1/8" to 7/32" (3.2 mm to 5.6 mm) thick and 3-1/2" (88 mm) minimum pulley diameters. They can be applied to all types of baler belting, including used belts.

The connecting pin is designed for long life. It is a large diameter (.140" or 3.6 mm) hardened spring, stainless steel material.

Alligator® Rivet

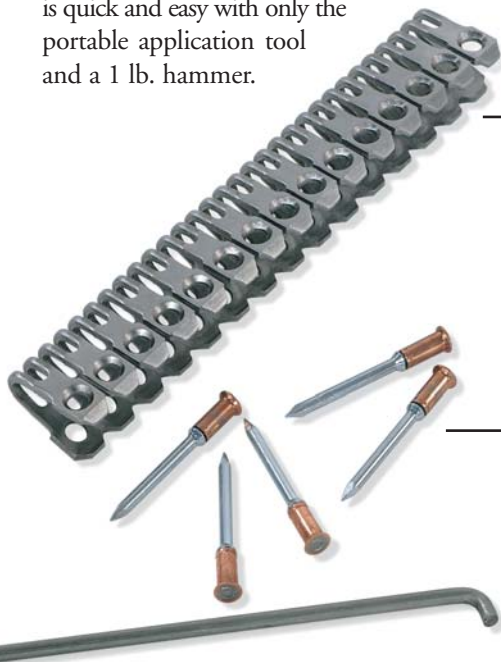

GOODYEAR
RUBBER PRODUCTS INC.

Call Toll Free: **1-866-711-4673**
WebSales@GoodyearRubberProducts.com

**We Ship
World Wide**

Alligator® Rivet Fastening System

Alligator® Rivet offers easy installation and low cost – without sacrificing reliability and long life. These advantages improve baler performance, bottom-line costs and overall productivity.

Fasteners, rivets, and connecting pins are made of strong, abrasion-resistant stainless steel. Additionally, the fastener's leading edge has a low profile to minimize snagging and wear on other components, such as rollers. Alligator Rivet is also compatible with net wrap balers.

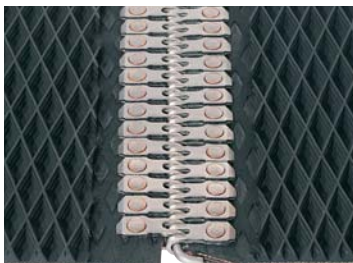

Fasteners

Belt Width		Ordering Number
in.	mm.	
4	100	ARJ4/100
6	150	ARJ6/150
7	175	ARJ7/175
10	250	ARJ10/250
14	350	ARJ14/350

Note: Each package includes fasteners, rivets and hinge pins for 2 complete splices.

Portable Hand Applicator Tool

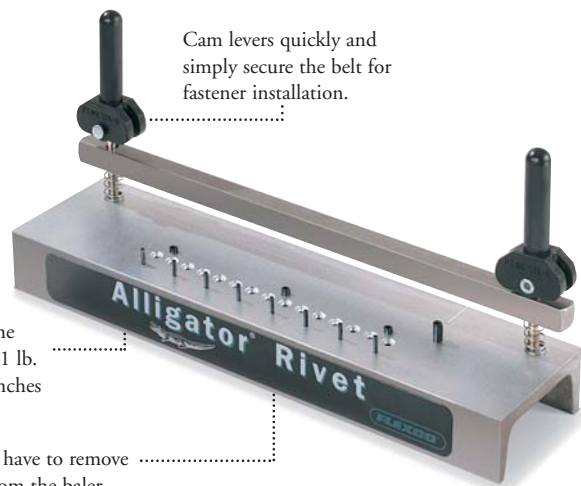

Cam levers quickly and simply secure the belt for fastener installation.

For field installation, all that's required is the applicator tool and a 1 lb. hammer – special punches are not required.

You never have to remove the belt from the baler.

Replacement Hinge Pins & Rivets

Description	Ordering Number	
	300 Series Stainless Spring Wire	Steel Corrugated
4" (100 mm) Hinge Pin - 9/Pkg.	ARSS1-4/100	ARSH4/100
6" (150 mm) Hinge Pin - 8/Pkg.	ARSS1-6/150	ARSH6/150
7" (175 mm) Hinge Pin - 6/Pkg.	ARSS1-7/175	ARSH7/175
10" (250 mm) Hinge Pin - 4/Pkg.	ARSS1-10/250	ARSH10/250
14" (350 mm) Hinge Pin - 4/Pkg.	ARSS1-14/350	ARSH14/350
Extra Rivets - 15/Pkg.	AR3-15	

Hand Applicator Tools & Tool Kits

Description	Ordering Number
7" (175 mm) Installation Tool	ART-7
14" (350 mm) Installation Tool	ART-14
7" (175 mm) Installation Kit	ARTK-7
14" (350 mm) Installation Kit	ARTK-14

Note: Each kit includes Installation Tool, Belt Hand Skiver, 1 lb. hammer, Pin Bender, and 2 packages of Alligator Rivet, packaged in durable plastic tool box.



Flexible Steel Lacing Company
 2525 Wisconsin Avenue
 Downers Grove, IL 60515-4200 U.S.A.
 Telephone: (630) 971-0150
 Fax: (630) 971-1180
 E-mail: advertising@flexco.com
 Visit our Web site at: www.flexco.com

Australia: 61-2-9680-3322 • England: 44-1457-891000 • Germany: 49-7428-9406-0 • Mexico: 52-5-674-5326
 New Zealand: 64-9-415-4488 • Republic of South Africa: 27-11-974-2771



©2001 Flexible Steel Lacing Company. 10/01-10, Part#X0657

Alligator® is a registered trademark of Flexible Steel Lacing Company. Patent Pending.



Call Toll Free: 1-866-711-4673
 WebSales@GoodyearRubberProducts.com

**We Ship
 World Wide**

NOW

CUSTOM MADE V-BELTS IN ANY LENGTH WITH ...

BELT
ALLIGATOR V FASTENERS

SIMPLE AS A, B, C,

ONE STRONG JOINT

- One strong joint permit *fast* and *easy* installation on all types of drives, particularly fixed center drives and drives with outboard bearings.
- Conveying with V-belts of either standard or "ruff" top design is now possible.
- V-belts can be made to any length. Center distances are no problem. Also, the high cost of special length belts can be avoided.
- Continual operation of machine is assured. When an endless belt breaks, merely cut off the required length of belt from a roll of Fastener-V-Belting, apply an Alligator V Fastener and the machine is ready to "roll" again.



**BULLETIN
No. V-227-B**

Supersedes
Bulletin
V-227-A3

GOODYEAR
RUBBER PRODUCTS INC.

Call Toll Free: 1-866-711-4673

WebSales@GoodyearRubberProducts.com

**We Ship
World Wide**

THE BELTING . . .

NOTE: Alligator V-Belt Fasteners should be used on a Fastener-V-Belting which is of cross-woven fabric construction. They are not to be used for repairing or splicing conventional endless V-belt of multicord construction. Here is why: - because there are no cross-woven cords in an endless belt, its holding power for a V Fastener is inadequate and a fastener would eventually pull out. Fastener-V-Belting has the necessary strength to eliminate fastener pullout under normal operating conditions.



End of belt enlarged to show construction is:

Manufactured of cross woven duck fabric maximum fastener grip-available in 100' and 250' rolls in the following types:



CONVENTIONAL "V" TYPE

Made in A, B, C and D cross sections.



DOUBLE "V" TYPE

Made only in "BB" cross sections.



"RUFF TOP"

Made in A, B, C and D cross sections.

. . . THE FASTENERS



- A312** - For "A" Belting (Packed 10 Sets per box)
- A312-S** - For "A" Belting (Packed 5 Sets per box)
- B437** - For "B" Belting (Packed 10 Sets per box)
- B437-S** - For "B" Belting (Packed 4 Sets per box)
- C531** - For "C" Belting (Packed 10 Sets per box)
- D750** - For "D" Belting (Packed 10 Sets per box)
- BB4** - For "BB" Double V Belting (Packed 10 Sets per box)

ALUMINUM END-PLATE FASTENERS FOR HIGH SPEED DRIVES I.E., 400-5500 FPM.

- ALB437** For "B" Belting (Packed 10 Sets per Box)
- ALC531** For "C" Belting (Packed 10 Sets per Box)

REFER TO PRICE SHEET FOR FASTENER SPARE PARTS LIST.

INSTALLATION TOOLS



HOLDER

REQUIRED

- A31255** - For "A" Fasteners (Included in every box of "A" Fasteners)
- B43755** - For "B" Fasteners
- C53155** - For "C" Fasteners
- BB455** - For "BB" Fasteners

D75060 - For "D" Fasteners
*For "D" Belting a heavy duty piercing tool (not picture) is supplied complete with Rocker Pin Tool.



ROCKER PIN TOOLS

REQUIRED

- For all Fasteners except D4M and A312.
- B43740** - For "B" & "BB" Fasteners
- C62540** - For C, and D Fasteners



TIGHTENER

OPTIONAL

- Desirable for fixed Center Drives-used to pull belt ends together in grooves of sheaves.
- B43750** - For "B" Fastener
- C53150** - For "C" Fastener
- D75050** - For "D" Fastener.



CUTTER

OPTIONAL

- C-62520** - For A, B, BB, C and D belting.

SAVE! ORDER COMPLETE PACKAGED KITS



A4

B3

BB3

C3

D3

containing 100' Belting and necessary installation tools-

A4 - Contains -

- 100' "A" Belt
- 10-A312 Fasteners
- 1-A31255 Holder
- 100' "B" Belt
- 10-B437 Fasteners
- 1-B43755 Holder
- 1-B43750 RP Tool
- 100' "BB" Belt
- 10-BB4 Fasteners
- 1-BB455 Holder
- 1-B43740 RP Tool
- 100' "C" Belt
- 10-C531 Fasteners
- 1-C53155 Holder
- 1-C62540 RP Tool
- 100' "D" Belt
- 10-D750 Fasteners

B3 - Contains -

BB3 - Contains -

C3 - Contains -

D3 - Contains -

INTRODUCTORY KITS

(Inexpensive kits for the small user "A" and "B" belts)



"SA1"

CONTENTS

- 20' "A" Fastener V-Belting
- 1-A31255 Holder
- 5-A312 Alligator V Belt Fasteners

"SA2"

CONTENTS

- 20' "B" Fastener V-Belting
- 1-B43755 Holder
- 4-B437 Alligator V Belt Fasteners
- 1-B43740 RP Tool

"TOOL ASSORTMENTS"

For the convenience of the user, tool kits for B and C Belting are available

No. B43711
Contents:

No. C31111
Contents:

GOODYEAR
RUBBER PRODUCTS INC.

Call Toll Free: **1-866-711-4673**

WebSales@GoodyearRubberProducts.com

**We Ship
World Wide**

HOW TO DETERMINE BELT LENGTH FOR AN EXISTING DRIVE INSTALLATION*

- 1** Identify belt cross section to be used by comparing cross section of belting being replaced with dimensions of A, B, C, and D belting shown below.

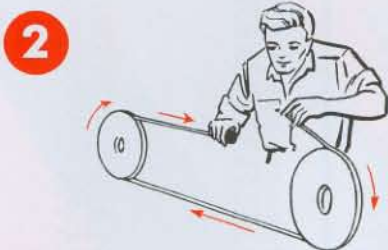
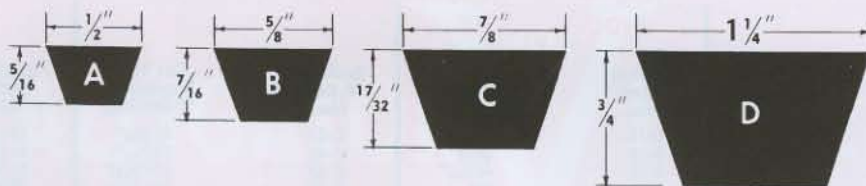

Determine outside circumference by wrapping a steel tape over the outside diameter of sheaves.

- 3** From measurement arrived at in Step 2.

a-Convert to pitch length (laid out flat length)

b-Allow for fastener opening

c-Allow for initial belt stretch

Refer to correction chart below for this information.

BELT LENGTH CORRECTION CHART

BELT SIZE	A	B	C	D
Correction deduction converting from outside circumference length to pitch length	7/8"	1 1/4"	1 3/4"	2 1/2"
Fastener Openings	3/8"	3/4"	1"	1"
TOTAL OF ABOVE	1 1/4"	2"	2 3/4"	2 1/2"
Initial Belt Stretch PER FOOT	3/32"	3/16"	3/16"	1/8"

EXAMPLE

If you have a "B" section drive with outside circumference of 140", deduct 2" for conversion to pitch length and for fastener opening. This leaves 138" from which you must deduct the allowance for initial stretch—3/8" times 11 1/2' (138")—or approximately 2 1/8". You should cut your Fastener-V-Belting 135 7/8" (138-2 1/8") when laid out flat and straight.

*When endless V-Belt size is known refer to Fastener-V-Belting replacement chart for correct cut lengths.

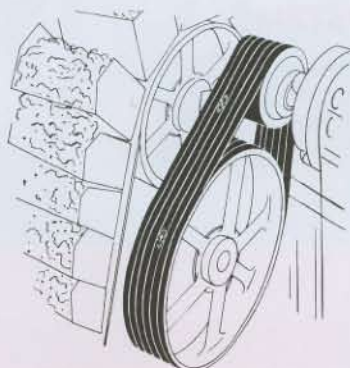

SAND & GRAVEL

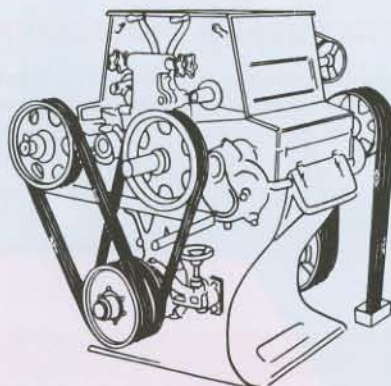

FLOUR MILL MACHINE

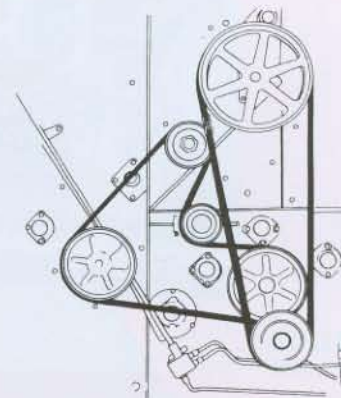

COTTON GIN

FASTENER-V-BELT REPLACEMENT CHART

FOR "A" SECTION ENDLESS V-BELT

Endless V-Belt No.	Cut Your Fastener-V-Belting
A-26	26 ¹ / ₂ "
A-31	31 ¹ / ₁₆ "
A-33	33 ⁷ / ₁₆ "
A-35	35 ⁷ / ₁₆ "
A-38	38 ³ / ₈ "
A-42	42 ³ / ₈ "
A-43	43 ³ / ₈ "
A-46	46 ⁵ / ₁₆ "
A-48	48 ⁵ / ₁₆ "
A-51	51 ⁵ / ₁₆ "
A-53	53 ¹ / ₄ "
A-55	55 ¹ / ₄ "
A-56	56 ¹ / ₄ "
A-60	60 ³ / ₁₆ "
A-62	62 ³ / ₁₆ "
A-64	64 ³ / ₁₆ "
A-66	66 ³ / ₁₆ "
A-68	68 ³ / ₁₆ "
A-70	70 ¹ / ₈ "
A-71	71 ¹ / ₈ "
A-75	75 ¹ / ₈ "
A-78	78 ¹ / ₈ "
A-80	80 ¹ / ₈ "
A-85	85"
A-90	90"
A-96	95 ¹⁵ / ₁₆ "
A-105	104 ⁷ / ₈ "
A-112	111 ³ / ₁₆ "
A-120	119 ³ / ₄ "
A-128	127 ¹ / ₁₆ "
A-136	135 ⁹ / ₁₆ "
A-144	143 ⁹ / ₁₆ "

No. A312 Alligator V-Belt Fastener is recommended for joining "A" Section Fastener-V-Belting.

FOR "B" SECTION ENDLESS V-BELT

Endless V-Belt No.	Cut Your Fastener-V-Belting
B-35	35 ³ / ₁₆ "
B-38	38 ¹ / ₈ "
B-42	42 ¹ / ₁₆ "
B-46	46"
B-48	48"
B-51	50 ¹⁵ / ₁₆ "
B-53	52 ¹ / ₁₆ "
B-55	54 ⁷ / ₈ "
B-56	55 ⁷ / ₈ "
B-60	59 ³ / ₁₆ "
B-62	61 ³ / ₄ "
B-64	63 ³ / ₄ "
B-65	64 ³ / ₄ "
B-66	65 ¹ / ₁₆ "
B-68	67 ¹ / ₁₆ "
B-71	70 ⁵ / ₈ "
B-75	74 ⁹ / ₁₆ "
B-78	77 ¹ / ₂ "
B-81	80 ¹ / ₂ "
B-83	82 ⁷ / ₁₆ "
B-85	84 ⁷ / ₁₆ "
B-90	89 ⁵ / ₁₆ "
B-93	92 ⁵ / ₁₆ "
B-97	96 ³ / ₁₆ "
B-100	99 ³ / ₁₆ "
B-103	102 ¹ / ₈ "
B-105	104 ¹ / ₈ "
B-108	107 ¹ / ₁₆ "
B-112	111"
B-120	118 ⁷ / ₈ "
B-124	122 ³ / ₁₆ "
B-128	126 ³ / ₄ "
B-133	131 ¹ / ₁₆ "
B-136	134 ⁹ / ₁₆ "
B-144	142 ¹ / ₂ "
B-158	156 ¹ / ₄ "
B-162	160 ³ / ₁₆ "
B-173	171"
B-180	177 ¹⁵ / ₁₆ "
B-195	192 ¹ / ₁₆ "
B-210	207 ⁷ / ₁₆ "
B-225	220 ³ / ₄ "
B-240	235 ¹ / ₂ "
B-255	250 ¹ / ₄ "
B-270	265"
B-285	279 ¹³ / ₁₆ "
B-300	294 ⁹ / ₁₆ "

No. B437 Alligator V-Belt Fastener is recommended for joining "B" section Fastener-V-Belting.

FOR "C" SECTION ENDLESS V-BELT

Endless V-Belt No.	Cut Your Fastener-V-Belting
C-51	51 ³ / ₁₆ "
C-60	60 ¹ / ₁₆ "
C-68	67 ¹⁵ / ₁₆ "
C-75	74 ¹³ / ₁₆ "
C-81	80 ³ / ₄ "
C-85	84 ¹ / ₁₆ "
C-90	89 ⁹ / ₁₆ "
C-96	95 ¹ / ₂ "
C-105	104 ⁵ / ₈ "
C-112	111 ¹ / ₄ "
C-120	119 ¹ / ₈ "
C-128	127"
C-136	134 ³ / ₈ "
C-144	142 ³ / ₄ "
C-158	156 ¹ / ₂ "
C-162	160 ⁷ / ₁₆ "
C-173	171 ⁵ / ₁₆ "
C-180	178 ³ / ₁₆ "
C-195	192 ¹⁵ / ₁₆ "
C-210	207 ¹ / ₁₆ "
C-225	220 ¹ / ₂ "
C-240	235 ¹ / ₄ "
C-255	250"
C-270	264 ¹³ / ₁₆ "
C-285	279 ⁹ / ₁₆ "
C-300	294 ⁵ / ₁₆ "
C-315	309 ¹ / ₁₆ "
C-330	323 ⁷ / ₈ "
C-345	338 ⁵ / ₈ "
C-360	353 ³ / ₈ "
C-390	382 ¹⁵ / ₁₆ "
C-420	412 ⁷ / ₁₆ "

No. C531 Alligator V-Belt Fastener is recommended for joining ¹/₂" thick "C" section Fastener-V-Belting.

FOR "D" SECTION ENDLESS V-BELT

Endless V-Belt No.	Cut Your Fastener-V-Belting
D-120	120 ¹ / ₄ "
D-128	128 ¹ / ₄ "
D-144	144"
D-158	157 ⁷ / ₈ "
D-162	161 ³ / ₈ "
D-173	172 ⁵ / ₈ "
D-180	179 ⁵ / ₈ "
D-195	194 ¹ / ₂ "
D-210	209 ¹ / ₄ "
D-225	221 ⁵ / ₈ "
D-240	236 ¹ / ₂ "
D-255	251 ³ / ₈ "
D-270	266 ¹ / ₈ "
D-285	281"
D-300	295 ⁷ / ₈ "
D-315	310 ³ / ₄ "
D-330	325 ¹ / ₂ "
D-345	340 ³ / ₈ "
D-360	355 ¹ / ₄ "
D-390	385"
D-420	414 ⁵ / ₈ "
D-480	474"
D-540	533 ³ / ₈ "
D-600	592 ³ / ₄ "

No. D750 Alligator V-Belt Fastener is recommended for joining "D" section Fastener-V-Belting.

MANUFACTURERS' NUMBERING SYSTEMS

There are several numbering systems used by V-Belting manufacturers. All the numbers in each column identify the same length belts.

A-26	B35	C51	D120
26A	35B	51C	120D
2A6	3B5	5C1	1D20

FLEXIBLE STEEL LACING COMPANY

2525 WISCONSIN AVENUE, DOWNERS GROVE, ILLINOIS 60515 U.S.A.

GOODYEAR
RUBBER PRODUCTS INC.

Call Toll Free: **1-866-711-4673**

WebSales@GoodyearRubberProducts.com

**We Ship
World Wide**

Unibar® fasteners feature performance-proven Clipper® hooks welded to a common bar for easier installation with less downtime.

Performance-proven **Clipper® Hooks** For Simplified Installation

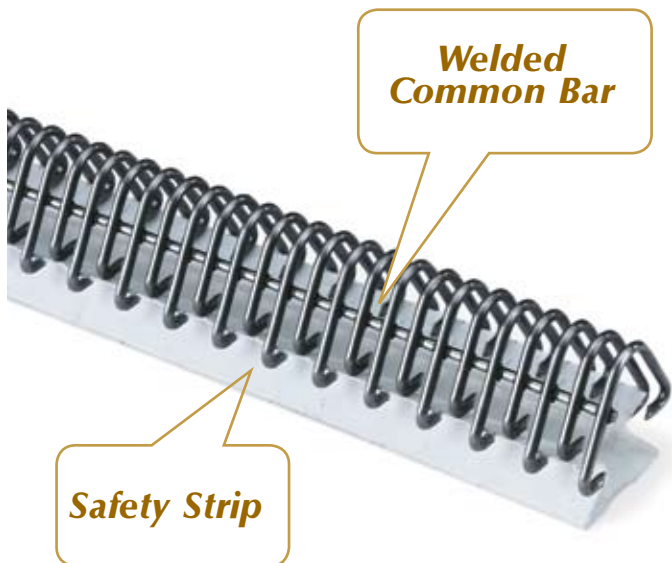

Faster.

- The welded common bar holds individual hook legs parallel during the installation process and creates a flat finished splice (no 'belt wave'). This combination eases the meshing of spliced belt ends and simplifies pin insertion.
- The Safety Strip can be quickly and easily removed either by sliding the paper off or gently pulling off the hook points.
- Available in 12" and 24" (300 and 600 mm) lengths standard; custom lengths available up to 60" (1500 mm), saving both installation time and money.

Safer.

- The Safety Strip keeps hook points covered to protect the user's fingers during handling and eliminates the product from being tangled during transportation.
- The risk of a single hook dislodging from the strip is virtually eliminated.

Smarter.

Each of the easier installation and reduced downtime features make Unibar wire hooks the Smart choice for these and many other applications:

- Package and Parts Handling
- Food Processing
- General Manufacturing
- Agriculture
- Filter Media

Unibar® Wire Hooks from Flexco

Specifications

Min. Pulley Diameter	Wire Thickness	Connecting Pin Size	Belt Thickness											
			Up to 3/64" 1.2mm	1/16" 1.6mm	3/32" 2.4mm	1/8" 3.2mm	5/32" 4.0mm	3/16" 4.8mm	7/32" 5.6mm	1/4" 6.4mm	17/64" 6.7mm	5/16" 7.9mm	11/32" 9.0mm	25/65" 10.0mm
15/16" 24mm	.036 x .027"	.065"/1.7mm	UCM36SL XSP											
	.036 x .027"	.065"/1.7mm		UCM36SL SP										
2" 51mm	.036 x .027"	.065"/1.7mm	UCM36 XSP											
	.036 x .027"	.065"/1.7mm		UCM36 SP*										
	.036 x .027"	.065"/1.7mm			UCM36*									
	.036 x .027"	.065"/1.7mm				UCM36 LP								
	.040"	.065"/1.7mm		UX1 SP*										
	.040"	.065"/1.7mm				UX1*								
	.054"	.093"/2.4mm				U2SP								
	.054"	.093"/2.4mm				U2								
3" 76mm	.054"	.093"/2.4mm						U3						
5" 127mm	.054"	.109"/2.8mm							U4					
	.054"	.125"/3.2mm									U5			
6" 152mm	.054"	.156"/4.0mm										U6		
7" 175mm	.054"	.156"/4.0mm											U7	

*Long Leg available; allow for 1" (25mm) larger pulley. Contact customer service for ordering information.

SL = Short Leg
XSP = Extra Short Point
SP = Short Point
LP = Long Point

Ordering Information

UX1, U2-U7: 430 Stainless Steel

Quantity - Length	UX1 SP	UX1	U2 SP	U2	U3	U4	U5	U6	U7
12 - 12" Strips	01184	01179	18851	18400	01255	01283	01305	18404	01294
10 - 24" Strips	01355	01356	18854	18477	18478	18479	01351	-	-

UCM36: 316 Stainless Steel

Quantity - Length	UCM36SLXSP	UCM36SLSP	UCM36XSP	UCM36SP	UCM36	UCM36LP
12 - 12" Strips	01315	01313	01312	01314	01309	01317
12 - 24" Strips	01319	01320	01321	01322	01323	-

UX1, U2-U5: 316 Stainless Steel

Quantity - Length	UX1 SP	UX1	U2	U3	U4	U5
12 - 12" Strips	01194	01189	18427	01258	18429	18430
10 - 24" Strips	01354	01353	18507	18508	18509	-

U2-U5: Coated Steel

Quantity - Length	U2 SP	U2	U3	U4	U5
12 - 12" Strips	18550	18370	01251	01279	01301
10 - 24" Strips	-	18453	18454	18455	01352



2525 Wisconsin Avenue
Downers Grove, IL 60515-4200 U.S.A.
Telephone: (630)-971-0150
Fax: (630)-971-1180
E-mail: info@flexco.com



www.flexco.com

GOODYEAR
RUBBER PRODUCTS INC.

Call Toll Free: **1-866-711-4673**
WebSales@GoodyearRubberProducts.com

**We Ship
World Wide**

Connecting Pins



Clipper

The connecting pin is a critical component of the splice. Unfortunately, the selection of a connecting pin is often an afterthought. Many users substitute various materials such as welding rod, baling wire, etc. The results can be catastrophic--pin breakage, premature wear of fastener loops, and unscheduled downtime.

Flexco offers a wide selection of Clipper® connecting pins specifically designed to provide long pin life and minimal wear to the fastener loops. Pins are available in pre-cut lengths, coil lengths, Pin Paks™ (convenient 100 ft. dispensing units), or specially fabricated with 'Leaders' or 'J' ends as noted below.

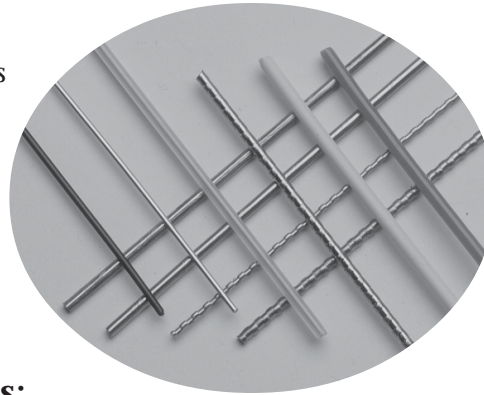

Simple Solutions for Difficult Problems:

Ease Pin Insertion: Inserting connecting pins into a wide belt can be difficult and time consuming, especially with a flexible connecting pin. A 'leader' is a rigid, smaller diameter pin that is attached to the connecting pin to help guide the larger diameter connecting pin through the splice. Depending on the connecting pin that has been chosen, the leader is formed in one of two methods:

Swaged Leader Assemblies

Using the Nylon Plus pin or one of the flexible cables (Nylon Covered Stainless Cable, Bare Stainless Cable, or DuraLink™), a small diameter music wire is swaged onto the connecting pin, forming a leader.

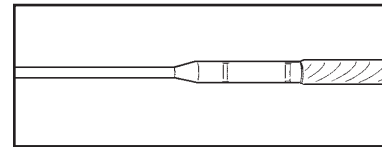

Swaged Leader Assembly

Stripped Leaders

A portion of the nylon coating of the Nylosteel, Nylostainless or DuraStainless™ pins can be stripped off, exposing the solid core. The stripped portion forms a leader. Flexco can provide this service or users can perform this simple function.

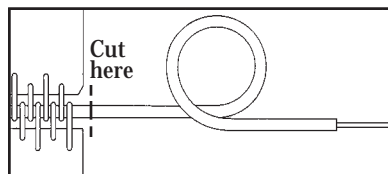

Stripped Leader

Leaders are fed through the width of the splice, allowing the connecting pin to be pulled through with ease. The leader is then cut off and discarded.

Avoid Pin Migration and Ease Pin Removal: Stripping 1/2" of the nylon coating and forming a 'J' on the end of a Nylosteel, Nylostainless, or DuraStainless pin allows the pin to lock in the splice. With the pin secured it is not able to migrate out of the splice. In addition, the 'J' end does not allow the pin to spin freely within the splice and focuses the wear on only one side of the pin. To remove, pull the pin until the 'J' end is out of the splice, rotate 90° until the smooth side of the pin is against the fastener loops and then pull the pin out.

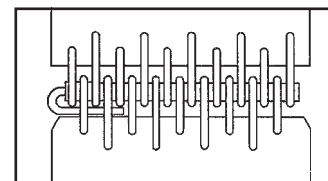

'J' End Pin

FLEXCO

Product Focus

Specifications

Pin Sizes (Diameter)	.053" 1.3mm	.065" 1.7mm	.079" 2.0mm	.093" 2.4mm	.109" 2.8mm	.125" 3.2mm	.156" 4.0mm
Hook Sizes	25	25, 36, 1, UX-1, UCM36, 30	1, 2, UX-1, U2	2SP, 2, 3, U2SP - U3, UA2 - UA3	4, U4	4½, 5, U5	6, 7, U6, U7

Pin Characteristics & Materials

Connecting Pin Types	Pin Wear Factor	Hook Wear Factor	Rigidity	Magnetic	Flexibility	Composition	Operating Temperature Range (° F)
Nylosteel	Good	Good	Good	Yes	Good	Nylon & music wire	-40 - + 250
Nylostainless	Good	Good	Good	Slightly	Good	Nylon & 316 SS wire	-40 - + 250
Nylon-Covered Stainless Cable	Good	Good	Fair	Slightly	Excellent	Nylon & 316 SS cable	-40 - + 250
Nylon Plus	Good	Excellent	Fair	No	Excellent	Nylon	-40 - + 370
Music Wire	Good	Poor	Excellent	Yes	Good	High-carbon spring-tempered steel	-40 - + 300
Steel	Average	Fair	Excellent	Yes	Fair to Poor	Mild cold-rolled steel	-40 - + 300
Stainless Steel	Average	Fair	Excellent	Slightly	Fair to Poor	302 or 316 SS	-40 - + 300
Duralink™	Excellent	Excellent	Fair	Slightly	Excellent	Wear-resistant nylon & 316 SS cable	-40 - + 250
Durastainless™	Excellent	Excellent	Good	Slightly	Good	Wear-resistant nylon & 316 SS spring wire	-40 - + 250
Bare Stainless Cable	Good	Good	Fair	Slightly	Excellent	316 SS cable	-40 - + 300

Ordering Information

'J' end pins, leader assemblies, and stripped leaders are all custom fabricated for the order. Contact Customer Service for ordering details.

Pin Material	Item Code	Pin Diameter							
		.053" 1.3mm	.054" 1.4mm	.065" 1.7mm	.079" 2.0mm	.093" 2.4mm	.109" 2.8mm	.125" 3.2mm	.156" 4.0mm
Nylosteel	Pin Pak Coil	18700 02594	N/A	02598 02597	18720 02595	02628 02627	02622 02621	02614 02613	02607 02606
Nylostainless	Pin Pak Coil	18701 02645	N/A	02649 02648	18721 02646	02670 02669	02664 02663	02658 02657	02652 02651
Nylon-Covered SS Cable	Pin Pak Coil	N/A	N/A	02751 02750	N/A	02767 02766	N/A	02762 02761	02756 02755
Duralink	Pin Pak Coil	N/A	N/A	02726 02725	N/A	02743 02742	02737 02736	02732 02731	N/A
DuraStainless	Pin Pak Coil	N/A	N/A	02826 02727	N/A	02830 02744	02834 02738	N/A	N/A
Smooth Steel	Pin Pak Coil	N/A	N/A 02771	N/A	N/A	N/A 02773	N/A	N/A	N/A
Notched Steel	Pin Pak Coil	N/A	N/A 02775	N/A	N/A	N/A 02777	N/A	N/A	N/A
Smooth SS	Pin Pak Coil	N/A	N/A 02779	N/A	N/A	N/A 02781	N/A	N/A	N/A
Notched SS	Pin Pak Coil	N/A	N/A 02783	N/A	N/A	N/A 02784	N/A	N/A	N/A
Bare Stainless Cable	Pin Pak Coil	N/A	N/A	N/A 02779	N/A	N/A 02781	N/A	N/A	N/A
Nylon Plus	Pin Pak Coil	02863 02868	N/A	02854 02853	02872 02869	02867 02866	02861 02860	02864 02870	02873 02871



Pin Pak™ contains a 100-foot coil of pin material in a convenient dispensing package.

Distributed by:

Flexible Steel Lacing Company

2525 Wisconsin Avenue
Downers Grove, IL 60515-4200 U.S.A.
Telephone: (630) 971-0150
Fax: (630) 971-1180
E-mail: advertising@flexco.com
Visit our website at: www.flexco.com



Clipper® is a registered trademark, and Pin Pak™, DuraStainless™ and DuraLink™ are trademarks of Flexible Steel Lacing Company.
©Flexible Steel Lacing Company 2000 Lit Code 1259-02 (X0821) Rev. 4/00



Call Toll Free: **1-866-711-4673**
WebSales@GoodyearRubberProducts.com

**We Ship
World Wide**

Roller Lacing Technology™



Flexco defined quick, on-site mechanical belt fastener installation when they pioneered Roller Lacing Technology™. This time-proven technology allows the lacer head to be driven across the width of the lacer while the dual rollers simultaneously and gradually install the Clipper® wire hooks with ease and speed.



Solutions for **On-Site Installation** *of Clipper® Wire Hooks*



What makes the Roller Lacer® ideal for On-Site Installation of Clipper® Wire Hooks?

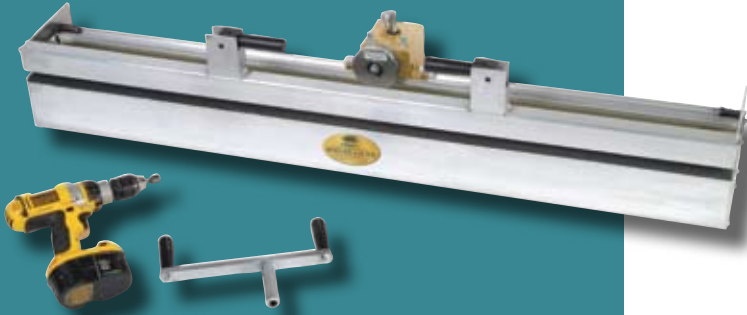

Roller Lacer® Gold Class™

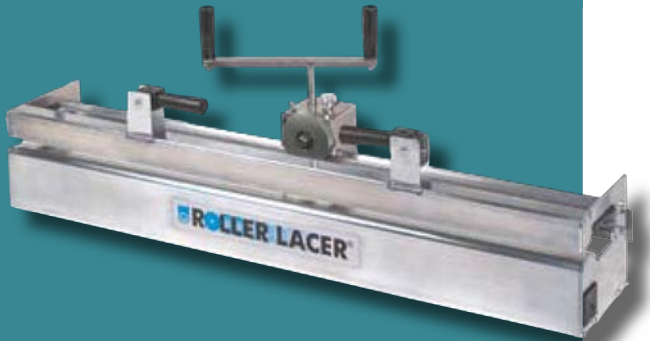

Manual Roller Lacer®



Microlacer®

Faster.

Reliable Clipper® splices are typically installed in less than 15 minutes, thanks to the wide lacer widths and the use of Roller Lacing Technology™. Quicker installation translates to less downtime, greater productivity, and increased profits.

Easier.

- Portable - Made from aircraft aluminum, the lacer remains lightweight and can be easily transported directly to the jobsite for fastener installation.
- Easy Installation - Simple installation procedures, combined with the ability to clamp and secure the belt, make splicing a one-person job.

Smarter.

With three different models to select from you are sure to find a lacer to best fit your needs.

- Roller Lacer® Gold Class™: Ideal for customers who either have a large number of belts in their facility or where minimizing downtime is crucial. This lacer offers maximum benefits for high speed installation and minimal operator effort through the use of a cordless drill to drive the lacer head and other features. Available in 24", 36", 48", and 60" widths (600, 900, 1200, 1500 mm).
- Manual Roller Lacer®: A great choice for customers with wide belts who desire quick, on-site installation. Available in 24", 36", 48", and 60" widths (600, 900, 1200, 1500 mm).
- Microlacer®: This 14" (350 mm) lacer is ideal for users with narrow belts or for low volume users.

Improved Roller Lacer® Features:

New Face Strip Design:

Face Strips have been redesigned with a solid bottom layer. This 3-layer design eliminates the need for locking levers and back-up bars necessary with previous models. This has removed installation steps and improved the reliability of the lacer by eliminating two common wear items.

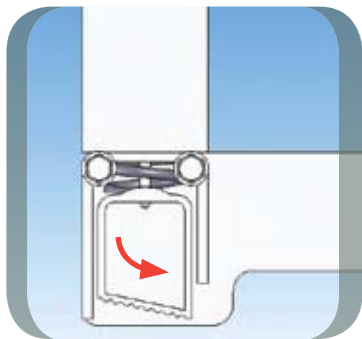

New Belt Clamp Design:

The inner clamp beam features a textured grip surface and when clamped it helps push the belt toward the Face Strip to allow proper hook reachback.



Improved Face Strip Storage:

Extruded slots in the lacer housing provide a secure yet easy to access storage location.



Increased Roller Shaft Diameter:

The larger diameter shaft provides the necessary support for the rollers to fully embed the hooks into the belt for a long-lasting splice.

Exclusive Features of the Roller Lacer® Gold Class™



Lacer head is driven with an 18 volt cordless drill for quicker installation and reduced operator fatigue.
(Drill not included with sale of lacer)



The clevis bracket and guide rollers provide additional stability to the lacer head and allow it to transverse with ease across the width of the lacer. The guide rollers are made of UHMW polyethylene for long wear life.



Belt Support Shelf easily guides belt into hook points, reducing operator time and effort.

Carrying Strap is included for easier transportation of the lacer to the jobsite.

Choosing the right lacer for your needs.

Feature	Roller Lacer® Gold Class™	Roller Lacer® Manual	Microlacer®
Ability to Drive Head with Cordless Drill	•		
Clevis Bracket/Outboard Rollers for Increased Lacer Head Stability	•		
Belt Support Shelf	•		
Carrying Strap	•		
Improved Belt Clamp	•	•	
Improved Face Strip Storage	•	•	•
New Face Strip Design	•	•	•
Elimination of Locking Lever and Back Up Bar Assembly	•	•	•
Increased Roller Shaft Diameter	•	•	•
Portable Lacer for On-Site Installation	•	•	•
Available in 24", 36", 48", and 60" Widths	•	•	14" Only
Ability to Continuous Lace Belts Wider Than Lacer Width	•	•	•

Face Strips sold separately.

Ordering Information—Roller Lacer®					
Belt Width		Roller Lacer® Gold Class™		Roller Lacer® Manual	
in	mm	Ordering Number	Item Code	Ordering Number	Item Code
24"	600	RL-G24	03985	RL-24	03370
36"	900	RL-G36	03986	RL-36	03371
48"	1200	RL-G48	03987	RL-48	03372
60"	1500	RL-G60	03988	RL-60	03375

Ordering Information—Face Strips					
Belt Width		Roller Lacer® Gold Class™		Roller Lacer® Manual	
in	mm	Ordering Number	Item Code	Ordering Number	Item Code
HOOK SIZE; 36, UCM36					
24"	600	FSGOLD36-24	04038	FSMAN36-24	04020
36"	900	FSGOLD36-36	04039	FSMAN36-36	04021
48"	1200	FSGOLD36-48	04040	FSMAN36-48	04022
60"	1500	FSGOLD36-60	04041	FSMAN36-60	04023
HOOK SIZE; 1, UX-1					
24"	600	FSGOLD1-24	04034	FSMAN1-24	04015
36"	900	FSGOLD1-36	04035	FSMAN1-36	04016
48"	1200	FSGOLD1-48	04036	FSMAN1-48	04017
60"	1500	FSGOLD1-60	04037	FSMAN1-60	04018
HOOK SIZE; 2-4, U2SP-U3					
24"	600	FSGOLD2-24	04042	FSMAN2-24	04025
36"	900	FSGOLD2-36	04043	FSMAN2-36	04026
48"	1200	FSGOLD2-48	04044	FSMAN2-48	04027
60"	1500	FSGOLD2-60	04045	FSMAN2-60	04028
HOOK SIZE; 4-1/2-7, U4-U7					
24"	600	FSGOLD4-1/2-24	04046	FSMAN4-1/2-24	04030
36"	900	FSGOLD4-1/2-36	04047	FSMAN4-1/2-36	04031
48"	1200	FSGOLD4-1/2-48	04048	FSMAN4-1/2-48	04032
60"	1500	FSGOLD4-1/2-60	04049	FSMAN4-1/2-60	04033

Face Strips sold separately.

Ordering Information—Microlacer®			
Belt Width		Microlacer®	
in	mm	Ordering Number	Item Code
14"	350	MICROLACER	03368

Ordering Information—Face Strips		
Hook Size	Microlacer®	
	Ordering Number	Item Code
36, UCM36	FSMAN36-MICRO	04019
1, UX-1	FSMAN1-MICRO	04014
2-4, U2SP-U3	FSMAN2-MICRO	04024
4-1/2-7, U4-U7	FSMAN4-1/2-MICRO	04029



2525 Wisconsin Avenue
Downers Grove, IL 60515-4200 U.S.A.
Telephone: (630)-971-0150
Fax: (630)-971-1180
E-mail: info@flexco.com



www.flexco.com

Australia: 61-2-9680-3322 • England: 44-1274-600-942 • Germany: 49-7428-9406-0 • Mexico: 52-55-5674-5326 • Republic of South Africa: 27-11-608-4180



Call Toll Free: **1-866-711-4673**
WebSales@GoodyearRubberProducts.com

**We Ship
World Wide**

Clipper® Roller Lacer®



CH210



The portable, easy-to-use Clipper® Roller Lacer® makes it easy to lace belts up to 60" (1500 mm) wide in a single operation. Belts wider than the lacer's width can be laced in multiple passes with the continuous lacing feature. A handle-actuated belt clamp holds belts securely while twin rollers embed fasteners evenly to create a strong, long-lasting splice.

Market applications

- Parcel services
- General material handling
- Corrugated box board
- Food processing
- Distribution centers
- Ag/Combine pick-up belts

A durable, lightweight body made from sturdy aircraft aluminum and a carrying handle make it easy to take the Roller Lacer on-site to lace belts right on the conveyor. Plus, there is room for extra lacer pins and face strips in a handy storage compartment.

For more frequent lacing applications, and/or when installing hooks into hard belts, specify the Roller Lacer with the optional steel lacing head.



Clipper®

Clipper® Roller Lacer®



Roller Lacer®

Does not include face strips – purchase separately.

Lacer Width		Ordering Number	
in.	mm	Standard Lacer	Steel Head Lacer
24	600	RL-24	SHRL-24
36	900	RL-36	SHRL-36
48	1200	RL-48	SHRL-48
60	1500	RL-60	SHRL-60

Roller Lacer® Face Strips

Includes one lacer pin.

Belt Width		Ordering Number
in.	mm	
For Hook Size: 30		
24	600	GFS30-24
36	900	GFS30-36
48	1200	GFS30-48
60	1500	GFS30-60
For Hook Size: 36, UCM36		
24	600	FS36-24
36	900	FS36-36
48	1200	FS36-48
60	1500	FS36-60
For Hook Size: 1, UX-1		
24	600	FS1-24
36	900	FS1-36
48	1200	FS1-48
60	1500	FS1-60
For Hook Size: 2-4, U2SP-U3		
24	600	FS2-24
36	900	FS2-36
48	1200	FS2-48
60	1500	FS2-60
For Hook Size: 4-1/2-7, U4-U7		
24	600	FS4-1/2-24
36	900	FS4-1/2-36
48	1200	FS4-1/2-48
60	1500	FS4-1/2-60



Flexible Steel Lacing Company

2525 Wisconsin Avenue
Downers Grove, IL 60515-4200 U.S.A.

Telephone: (630) 971-0150

Fax: (630) 971-1180

E-mail: advertising@flexco.com

Visit our Web site at: www.flexco.com

Australia: 61-2-9680-3322 • England: 44-1457-891000 • Germany: 49-7428-9406-0
Mexico: 52-55-5674-5326 • New Zealand: 64-9-415-4488 • Republic of South Africa: 27-11-974-2771

© 2003 Flexible Steel Lacing Company. 7/03, Part#X0731
Clipper® and Roller Lacer® are registered trademarks of Flexible Steel Lacing Company.



GOODYEAR
RUBBER PRODUCTS INC.

Call Toll Free: 1-866-711-4673
WebSales@GoodyearRubberProducts.com

**We Ship
World Wide**

The Roller Lacer® has long been known for its ease of use and speed when installing Clipper® Wire Hooks on-site with minimal downtime. Recently, significant advancements have been made to bring you a 'Golden Opportunity' to increase belt conveyor uptime and reduce operator fatigue, resulting in the Roller Lacer® Gold Class.



What makes the Roller Lacer® Gold Class™ the Optimal Choice for on-site installation of Clipper® Wire Hooks?



Patent Pending

Faster.

- The lacer head is power assisted by an 18 volt cordless drill, reducing the amount of time required to install hooks by 35%.
- Belt support shelf helps to easily guide the belt between hook points significantly reducing operator effort and time.

Easier.

- Driven by a cordless drill, the operator fatigue is significantly reduced and repetitive motion from manually turning the drive handle is eliminated.
- The new Face Strip design securely holds hooks during installation, eliminating the need for locking levers and back up bars. The result: Fewer installation steps, a lighter tool, and improved reliability of the lacer.

Smarter.

The smarter choice is to "Go for the Gold" when it comes to installation of Clipper® splices! Choosing the Roller Lacer Gold Class saves time, frustration and operator energy, while increasing your conveyor belt uptime and ultimately your bottom line.

New Features

Roller Lacer® Gold Class™



The devis bracket and UHMW polyethylene guide rollers provide additional stability to the lacer head and allow it to transverse with ease across the width of the lacer.



Belt support shelf gently guides belt into open hook points.



Improved, built-in Face Strip storage.



Flexible Steel Lacing Company
2525 Wisconsin Avenue
Downers Grove, IL 60515-4200 U.S.A.
Telephone: (630)-971-0150
Fax: (630)-971-1180
E-mail: info@flexco.com



- **Lacer head can be driven by a cordless drill** (18 volt or higher); reducing time and fatigue with installing splices. Built-in safety features prevent the lacer head from contacting end plates. A manual drive handle is supplied for use if drill has lost its charge.

- **Improved belt clamping design** provides greater holding force for the belt with the same simple operating procedure.

- **New Face Strip design** eliminates the need for locking levers and back up bars. This not only reduced installation steps and time, but also eliminated common repair parts with previous models.

- **12" (300 mm) additional length** to the tool allows the lacer to be secured easier on conveyor structure, such as side wall pans, for greater stability when lacing.



Drill not included with lacer purchase.

Face Strips sold separately.

Ordering Information—Roller Lacer®

Belt Width		Roller Lacer® Gold Class™		Roller Lacer® Manual	
in	mm	Ordering Number	Item Code	Ordering Number	Item Code
24"	600	RL-G24	03985	RL-24	03370
36"	900	RL-G36	03986	RL-36	03371
48"	1200	RL-G48	03987	RL-48	03372
60"	1500	RL-G60	03988	RL-60	03375

Ordering Information—Face Strips

Belt Width		Roller Lacer® Gold Class™		Roller Lacer® Manual	
in	mm	Ordering Number	Item Code	Ordering Number	Item Code
HOOK SIZE; 36, UCM36					
24"	600	FSGOLD36-24	04038	FSMAN36-24	04020
36"	900	FSGOLD36-36	04039	FSMAN36-36	04021
48"	1200	FSGOLD36-48	04040	FSMAN36-48	04022
60"	1500	FSGOLD36-60	04041	FSMAN36-60	04023
HOOK SIZE; 1, UX-1					
24"	600	FSGOLD1-24	04034	FSMAN1-24	04015
36"	900	FSGOLD1-36	04035	FSMAN1-36	04016
48"	1200	FSGOLD1-48	04036	FSMAN1-48	04017
60"	1500	FSGOLD1-60	04037	FSMAN1-60	04018
HOOK SIZE; 2-4, U2SP-U3					
24"	600	FSGOLD2-24	04042	FSMAN2-24	04025
36"	900	FSGOLD2-36	04043	FSMAN2-36	04026
48"	1200	FSGOLD2-48	04044	FSMAN2-48	04027
60"	1500	FSGOLD2-60	04045	FSMAN2-60	04028
HOOK SIZE; 4-1/2-7, U4-U7					
24"	600	FSGOLD4-1/2-24	04046	FSMAN4-1/2-24	04030
36"	900	FSGOLD4-1/2-36	04047	FSMAN4-1/2-36	04031
48"	1200	FSGOLD4-1/2-48	04048	FSMAN4-1/2-48	04032
60"	1500	FSGOLD4-1/2-60	04049	FSMAN4-1/2-60	04033

Manual Roller Lacer®

For customers with lower volume installation, the manual driven Roller Lacer is still available. The belt clamp and face strip innovations noted earlier are standard on this lacer.



www.flexco.com

Australia: 61-2-9680-3322 • England: 44-1274-600-942 • Germany: 49-7428-9406-0 • Mexico: 52-5556-74-53-26 • Republic of South Africa: 27-11-971-2771

GOODYEAR
RUBBER PRODUCTS INC.

Call Toll Free: **1-866-711-4673**
WebSales@GoodyearRubberProducts.com

**We Ship
World Wide**

Clipper® Microlacer®



Weighing less than 21 lbs. (9.5 kg), the Microlacer® is the lightweight, easy-to-operate solution for lacing belts on-site, and it creates a quality, long-lasting splice in minutes. Use it to lace belts up to 14" (350 mm) wide in one operation. Wider belts can be laced in multiple operations with the continuous lacing feature.

A durable, lightweight body made from sturdy aircraft aluminum and a carrying handle make it easy to lace belts right on the conveyor. The belt clamp bar grips belts of any type or thickness – freeing the operator's hands for one-person operation. Twin rollers embed fasteners evenly, and adjustable pressure ensures just the right amount of clinch.



Market applications

- Agriculture
- Distribution centers
- Bottling plants
- Food processing
- General manufacturing
- Box board plants

Microlacer®

Does not include face strips – purchase separately.

Lacer Width		Ordering Number
in.	mm	
14	350	Microlacer

Microlacer® Face Strips

Includes one lacer pin.

For Hook Size:	Ordering Number
30	MFS30-14
36, UCM36	FS36-MICRO
1, UX-1	FS1-MICRO
2-4, U2SP-U3	FS2-MICRO
4-1/2-7, U4-U7	FS4-1/2-MICRO



Flexible Steel Lacing Company
 2525 Wisconsin Avenue
 Downers Grove, IL 60515-4200 U.S.A.
 Telephone: (630) 971-0150
 Fax: (630) 971-1180
 E-mail: advertising@flexco.com
 Visit our Web site at: www.flexco.com



Australia: 61-2-9680-3322 • England: 44-1457-891000 • Germany: 49-7428-9406-0
 Mexico: 52-55-5674-5326 • New Zealand: 64-9-415-4488 • Republic of South Africa: 27-11-974-2771

© 2003 Flexible Steel Lacing Company. 7/03, Part#X0732
 Clipper® and Microlacer® are registered trademarks of Flexible Steel Lacing Company.

Clipper®

Clipper® Vise Lacer



The Clipper® Vise Lacer is the ideal lacing tool for the user with only a few conveyor belts, while providing the reliability and performance of a machine splice. It is also easy to use and inexpensive.

Simply place the lacer in a vise, load the hooks, insert the belt, and close the vise. The exclusive built-in pressure plate ensures a consistent clinch for long-lasting splices. And the Acusteel™ Hook Retainer produces an optimal loop profile for maximum splice performance.

Vise Lacers are available for all series of Clipper hook sizes in widths up to 10" (250 mm). Wider belts can be laced in multiple operations with the easy-to-use continuous lacing feature.



Vise Lacer

For Hook Size:	Tool Width		Ordering Number
	in.	mm	
2-7, U2SP-U7	4	100	R-4
2-7, U2SP-U7	7	175	R-7
2-7, U2SP-U7	10	250	R-10
1, UX-1	7	175	1VL-7
25*	7	175	25VL-6
30, 36, UCM36	7	175	36VL-7

*25 Lacers have a slightly different construction.

Market applications

- Agriculture
- Food processing
- Bowling alleys
- Laundry & textiles
- General manufacturing



Flexible Steel Lacing Company
 2525 Wisconsin Avenue
 Downers Grove, IL 60515-4200 U.S.A.
 Telephone: (630) 971-0150
 Fax: (630) 971-1180
 E-mail: advertising@flexco.com
 Visit our Web site at: www.flexco.com



Australia: 61-2-9680-3322 • England: 44-1457-891000 • Germany: 49-7428-9406-0
 Mexico: 52-55-5674-5326 • New Zealand: 64-9-415-4488 • Republic of South Africa: 27-11-974-2771

© 2003 Flexible Steel Lacing Company. 7/03, Part#X0734
 Acusteel™ is a trademark and Clipper® is a registered trademark of Flexible Steel Lacing Company.

Clipper®

Flexco® Bolt Solid Plate Fastener System

BSP200



When belt top covers are 3/16" (5 mm) or more, countersinking (recessing) fastener plates is recommended.

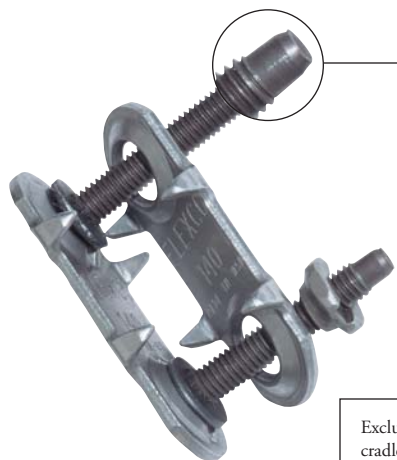

Exclusive tapered tip cradles nuts securely in place.

Easy to use.

Reduces installation time.

Flexco® Bolt Solid Plate fasteners are engineered to meet the demands of the toughest material handling applications, providing a strong sift-free splice and superior holding ability. A choice of sizes accommodates belts from 3/16" (5 mm) to over 15/16" (24 mm) thick.

High strength

High strength is the result of superior design and plate compression on both the top and bottom sides of the belt. High tensile strength bolts compress top and bottom plates to distribute splice tension evenly across the entire width of each fastener plate. For added strength and pull-out resistance, specially formed teeth penetrate deep into the belt carcass – without damaging carcass fibers.

Easy installation

Field-proven templates, punches, and boring tools make it easy to quickly and accurately prepare belts for fastener installation. Fasteners are easily installed on-site using portable hand tools or power tools. Our exclusive piloted bolts also contribute to faster installation.

Market applications

- Sand
- Gravel
- Crushed stone
- Grain
- Coal
- Cement
- Salt

Flexco® Bolt Solid Plate Fastener Selection Guide

Fastener Size	Belt Thickness Range		For Belts with Mechanical Fastener Ratings Up To:		Recommended Minimum Pulley Diameter (Operating Tension 75% -100% of Belt Rating)	
	in.	mm	P.I.W.	kN/m	in.	mm
1	3/16 - 7/16	5 - 11	150	30	12	300
140	3/16 - 7/16	5 - 11	225	40	14	350
190	5/16 - 9/16	8 - 14	330	60	18	450
1-1/2	7/16 - 11/16	11 - 17	300	50	18	450
2	9/16 - 13/16	14 - 21	440	75	30	750
2-1/4	9/16 - 1-3/16	14 - 30	620	105	36	900
2-1/2	3/4 - 1	19 - 25	450	75	42	1050
3	15/16 & over	24 & over	560	100	48	1200

FLEXCO® Bolt Solid Plate

Flexco® Bolt Solid Plate Fastener System

Fasteners

Each “E” box contains 25 complete fastener sets. A set consists of a top plate, a bottom plate, two nuts, two bolts, and an assembly clip.



“E” Box

(25 Fastener Sets)

Ordering Number			
Steel	Stainless – 300 Series	MegAlloy® Top Plates Balance Steel	MegAlloy® Top & Bottom Plates, Steel Bolts & Nuts
1E			
140E	140ES	140EMA	140EMAP
190E	190ES	190EMA	190EMAP
1-1/2E	1-1/2ES	1-1/2EMA	1-1/2EMAP
2E	2ES	2EMA	2EMAP
2-1/4E	2-1/4ES	2-1/4EMA	2-1/4EMAP
2-1/2*			
3*			

*10 Fastener Sets

NOTE: Other metals are also available in “E” boxes.

“C” Bucket

(100 Fastener Sets – Bottom Plates Pre-Assembled)

Ordering Number		
Steel	MegAlloy® Top Plates Balance Steel	MegAlloy® Top & Bottom Plates, Steel Bolts & Nuts
1C		
140C	140CMA	140CMAP
190C	190CMA	190CMAP
1-1/2C	1-1/2CMA	1-1/2CMAP
2C	2CMA	2CMAP
2-1/4C	2-1/4CMA	
2-1/2C*		
3C*		

* Packaged in Cartons

NOTE: Other metals are also available in “C” buckets.

Rip Repair

Use standard Flexco® Solid Plate fasteners to repair conveyor belt holes and edge tears. For jagged length-wise conveyor belt tears, standard Bolt Solid Plate fasteners can be combined with three-bolt Rip Repair fasteners. Three-bolt Rip Repair fasteners can also be used to bridge “soft” spots in the belt before they become rips.



Rip Repair Fasteners

Ordering Number	Box Qty.
Steel	
RP1E	25
RP2E	25
2-1/4E	25
Stainless	
RP1ES	25
RP2ES	25
2-1/4ES	25

Fastener Sets Required For A Complete Joint

Belt Width	Fastener Size 1, 140 & 190		Fastener Size 1-1/2, 2 & 2-1/4		Fastener Size 2-1/2 & 3								
	90°	45°	90°	45°	90°	45°							
in.	mm	in.	mm	in.	mm	in.	mm	in.	mm				
12	300	10	9	12	12	8	8	9	10	6	6	7	7
18	450	15	14	19	19	12	11	15	15	9	9	12	12
24	600	20	19	26	26	16	15	21	21	13	13	17	16
30	750	25	24	33	33	20	19	27	27	16	16	21	21
36	900	30	29	41	40	24	23	33	32	19	19	26	26
	1000		32		45		26		36		21		29
42	1050	35	34	48	47	28	27	39	38	22	21	31	30
48	1200	40	39	55	54	32	31	44	43	26	26	35	35
54	1350	45	44	63	61	36	35	48	49	29	29	40	40
60	1500	50	49	69	68	40	39	56	55	32	32	44	44
72	1800	60	59	83	82	48	47	68	65	39	39	53	53

Flexco® Bolt Solid Plate Installation Tools and Supplies

The only tools needed for Bolt Solid Plate fastener installation are a templet and portable hand tools or power tools such as wrenches and belt punches. Impact wrench driven power tools are recommended, and can reduce installation time by at least 50%.



Hand Tools



Power Tools

Hand Installation Tools

Description	For Fastener Number	Ordering Number
Bolt Horn		2BH
Punch	1, 140, 190 & RP1	P1P
	1-1/2, 2, 2-1/4 & RP2	P2P
	2-1/2 & 3	P3P
Boring Bit	1, 140, 190 & RP1	B1B
	1-1/2, 2, 2-1/4 & RP2	B2B
	2-1/2 & 3	B3B
Wrench	1, 140, 190 & RP1	S1S
	1-1/2, 2, 2-1/4 & RP2	S2S
	2-1/2 & 3	S3S

Power Installation Tools

Description	For Fastener Number	Ordering Number
Power Punch	1, 140, 190 & RP1	HP1
	1-1/2, 2, 2-1/4 & RP2	HP2
	2-1/2 & 3	HP3
Power Boring Bit	1, 140, 190 & RP1	HB1
	1-1/2, 2, 2-1/4 & RP2	HB2
	2-1/2 & 3	HB3
Power Wrench	1, 140, 190 & RP1	HW1
	1-1/2, 2, 2-1/4 & RP2	HW2
	2-1/2 & 3	HW3
Quick Change Chuck		5552

Bolt Breaker

Description	For Fastener Number	Ordering Number
Bolt Breaker (Two Per Package)	1, 140, 190 & RP1	110
	1-1/2, 2, 2-1/4 & RP2	112
	2-1/2 & 3	113



Bolt Breaker

Flexco-Lok® Tape

Rigid nylon tape helps eliminate belt ripples on plied or solid-woven belting, so belts run smoothly over pulleys and under cleaners. Also helps seal splices against seepage of fines and moisture.

Flexco-Lok®
Belt Tape (100' per Carton)

Fastener Size	Ordering Number
1 & 140	FL7C
190, 1-1/2	FL11C
2 & 2-1/4	



Flexco® Cracking Chisel

With a hammer and cracking chisel, individual worn plates can be easily replaced – without resorting to replacement of the entire splice.

Cracking Chisel

Nut Size	Ordering Number
1, 140 & 190	C1C
1-1/2, 2 & 2-1/4	C2C



Flexco® Bolt Solid Plate Fastener System

90° and 45° Templets

Templets are required for 90° and 45° Bolt Solid Plate fastener installation. Templets simplify installation by providing a guide for accurate bolt-hole placement. Lengths for all standard belt widths are available.



90° Templets

Belt Width		Ordering Number							
in.	mm	1	140	190	1-1/2	2	2-1/4	2-1/2	3
12	300	1-12	140-12	190-12	1-1/2-12	2-12			
16	400	1-16	140-16	190-16					
18	450	1-18	140-18	190-18	1-1/2-18	2-18			
24	600	1-24	140-24	190-24	1-1/2-24	2-24	2-1/4-24	2-1/2-24	
30	750	1-30	140-30	190-30	1-1/2-30	2-30	2-1/4-30	2-1/2-30	
36	900	1-36	140-36	190-36	1-1/2-36	2-36	2-1/4-36	2-1/2-36	3-36
42	1050	1-42	140-42	190-42	1-1/2-42	2-42	2-1/4-42	2-1/2-42	3-42
48	1200	1-48	140-48	190-48	1-1/2-48	2-48	2-1/4-48	2-1/2-48	3-48
60	1500				1-1/2-60	2-60	2-1/4-60	2-1/2-60	3-60

45° Templets



Belt Width		Ordering Number				
in.	mm	1	140	190	1-1/2	2
12	300	1-12-45				
18	450	1-18-45		190-18-45	1-1/2-18-45	
24	600	1-24-45	140-24-45	190-24-45	1-1/2-24-45	2-24-45
30	750	1-30-45	140-30-45	190-30-45	1-1/2-30-45	2-30-45
36	900	1-36-45	140-36-45	190-36-45	1-1/2-36-45	2-36-45
42	1050		140-42-45	190-42-45	1-1/2-42-45	2-42-45
48	1200	1-48-45	140-48-45	190-48-45	1-1/2-48-45	
60	1500		140-60-45	190-60-45	1-1/2-60-45	2-60-45



Flexible Steel Lacing Company
 2525 Wisconsin Avenue
 Downers Grove, IL 60515-4200 U.S.A.
 Telephone: (630) 971-0150
 Fax: (630) 971-1180
 E-mail: advertising@flexco.com
 Visit our Web site at: www.flexco.com

Australia: 61-2-9680-3322 • England: 44-1457-891000 • Germany: 49-7428-9406-0
 Mexico: 52-55-5674-5326 • New Zealand: 64-9-415-4488 • Republic of South Africa: 27-11-974-2771

© 2003 Flexible Steel Lacing Company. 7/03, Part#X0746
 Flexco®, Flexco-Lok® and MegAlloy® are registered trademarks of Flexible Steel Lacing Company.



Flexco®

Conveyor Belt Rip Repair Fasteners

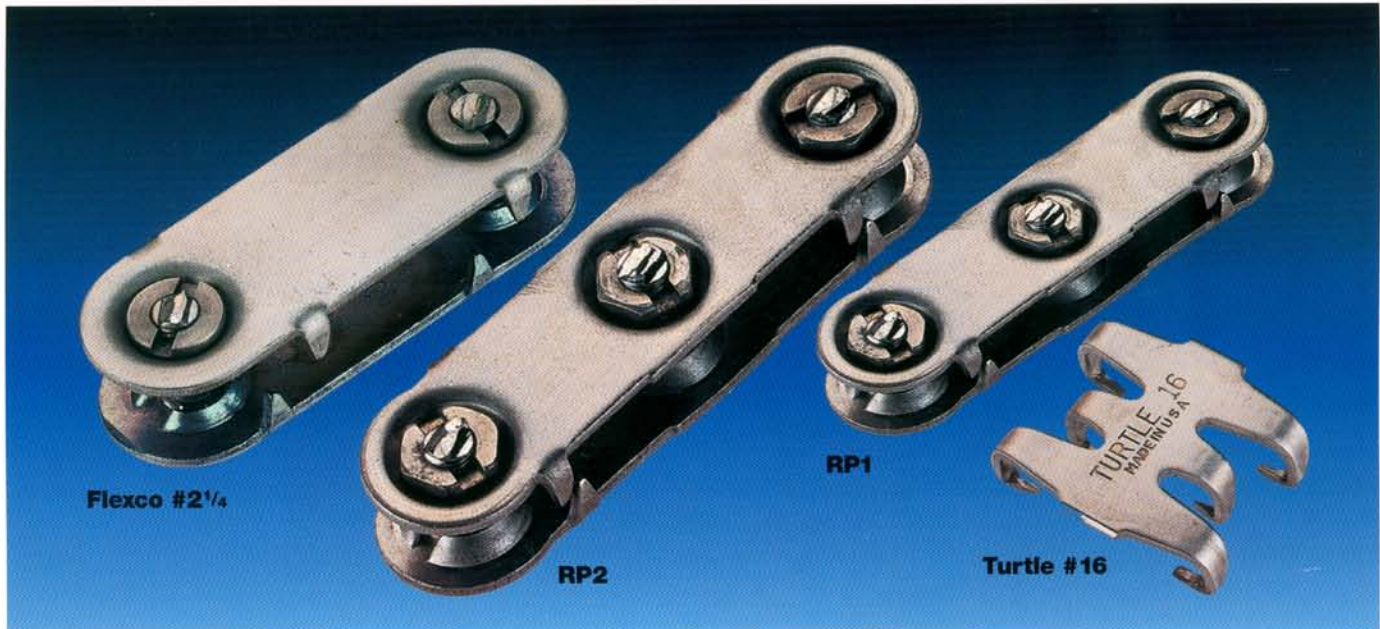

Reduce Repair Downtime, Cut Costs

Jagged-edged materials or tramp iron, such as tools or parts from broken equipment, can take a heavy toll on your conveyor system. Such materials can catch on your conveyor's support structure and idlers, tangle around rollers, and finally punch through and rip even the thickest belts, slitting or tearing the belt to the point it must be shut down and repaired.

It's hard to prevent this kind of sudden damage. But, with FLEXCO® Conveyor Belt Rip Repair Fasteners, it's not hard to prevent lengthy downtime, expensive repairs, and costly lost production.

FLEXCO Rip Repair Fasteners provide a rapid, cost-effective solution to repairing lengthwise rips and worn sections in belts — from 3/16" (5mm) to 1-3/16"

FLEXCO Rip Repair Fasteners:

- (1) are usually installed from the top side of the belt, requiring as little as 20 minutes of installation time for most rips,
- (2) lower your repair costs,
- (3) result in zero belting waste, and
- (4) can be installed by on-site workers using common hand tools.

(30mm) thick, including steel cable constructions. They temporarily preserve the strength and integrity of damaged conveyor belts — with minimal downtime. Offered also in stainless steel and other non-

magnetic alloys, FLEXCO Rip Repair Fasteners will not interfere with the performance of magnetic pulleys or separators.

And, if your application has a recurring problem with rips and tears, we can help you put together a FLEXCO Rip Repair emergency kit. Always on hand, complete with installation tools and different size fasteners, the emergency kit will enable you to respond quickly and cut downtime costs even further.

FLEXCO Rip Repair Fasteners keep your belt — and your production — moving until permanent repair can be scheduled during planned downtime. Integrate FLEXCO Conveyor Belt Rip Repair Fasteners into your operations and see just how dramatically you can speed up your recovery from belt damage.

Choose the FLEXCO® Conveyor Belt Rip Repair Fastener that fits your rip repair needs.

For repairing jagged rips, bridging soft spots.

To repair jagged rips or to bridge soft spots before they become rips, our three-bolt Rip Plates (RP1 and RP2) are the answer. These plates are extra long and should be installed crosswise to the belt. Two of the three bolts should be placed on the weak, or "flap," side of a jagged tear to increase stability. Alternating two- and three-bolt rip repair fasteners is recommended. Rip Repair Fasteners are installed with the same punches, wrenches and bolt breakers as FLEXCO Bolt Solid Plate Fasteners.



Flexco RP and Bolt Solid Plate Fasteners



Turtle® Rip Repair Fasteners

For fast, temporary rip repairs.

For quick, temporary rip repairs, select No. 16 Turtle® one-piece drive-on fasteners. Installed using only a hammer, the Turtle fastener should be placed every 4" to 6" along the rip. (Adding FLEXCO Bolt Solid Plate Fasteners between each Turtle fastener will give extended service to the repair until the belt can be permanently repaired or replaced.) A box of 50 Turtle fasteners will repair rips approximately 25 feet long.

NOTE: Turtle fasteners are recommended only for temporary rip repairs. They are never to be used for joining belt ends together.

For repairing straight lengthwise rips, repairing edge tears, patching holes in belting.

For repairing straight, lengthwise rips and edge tears and patching holes in belting, we recommend standard FLEXCO® Nos. 140, 190, 2 and 2-1/4 Bolt Solid Plate Fasteners.

For repairing straight, lengthwise rips in heavy-duty belts from 9/16" (14mm) to 1-3/16" (30mm) thick, or in steel cable belts, use standard FLEXCO Bolt Solid Plate No. 2-1/4 Fasteners.



Flexco Bolt Solid Plate Fasteners

Make rapid repairs with hand or power installation tools.

FLEXCO Rip Repair Fasteners are installed using simple, portable hand or power tools, including a punch or a boring bit, a wrench, and two bolt breakers. With impact wrench-driven power tools, you can cut installation time by up to one-half. To use power tools, you'll need a Quick Change Chuck, which adapts FLEXCO tools to the square drive stud on air or electric impact wrenches.

For more complete ordering information on FLEXCO® Bolt Solid Plate Fasteners or FLEXCO installation tools, please see the FLEXCO Bolt Solid Plate fastener catalog.

Ordering Numbers for Rip Plates and No. 16 Turtle® Fasteners

Belt Thickness in.	Fastener Size	Fastener Metal						Box Qty.	
		Steel		Stainless		Everdur*			
		Ordering Number	Item Code	Ordering Number	Item Code	Ordering Number	Item Code		
3/8-9/16	10-14	No. 16	16	20206					50
1/4-1/2	6-13	RP1	RP1E	20010	RP1ES	20041			25
3/8-13/16	10-21	RP2	RP2E	20011	RP2ES	20042			25
9/16-13/16	14-30	2 1/4	2 1/4E	20006	2 1/4ES	20040	2 1/4EE	20096	25

*EVERDUR is a trademark of American Brass. It is anti-magnetic and relatively spark-free when compared with steel.



FLEXIBLE STEEL LACING COMPANY

2525 Wisconsin Avenue
Downers Grove, IL 60515-4200 USA
Telephone: +1-630-971-0150
Fax: +1-630-971-1180
E-mail: advertising@flexco.com



DISTRIBUTED BY:

GOODYEAR
RUBBER PRODUCTS INC.

Call Toll Free: **1-866-711-4673**

WebSales@GoodyearRubberProducts.com

**We Ship
World Wide**

Flexco® Bolt Hinged Fastener System



No. 375X



No. 550



Exclusive tapered tip
cradles nuts securely in place.

Easy to use.

Reduces
installation time.

Sturdy hinged construction makes Flexco® Bolt Hinged fasteners ideal for applications that use smaller pulleys, but still require a high-strength, dependable splice. A choice of sizes accommodate belts from 1/4" (6 mm) to 5/8" (16 mm) thick.

Versatile, easy-to-install design

For belt conveyor applications subject to frequent length adjustments, the Bolt Hinged fastener is easy to install – and re-install. The joint can be separated simply by removing the hinge pin.

On-site installation requires hand or power tools. Our exclusive piloted bolt also simplifies installation and holds fastener plates firmly in place. For added strength and pull-out resistance, specially formed teeth penetrate deep into the belt carcass without damaging carcass fibers.

Market applications

- Construction and Road Equipment
- Coal • Salt • Potash • Grain
- Wood Products • Recycling

Flexco® Bolt Hinged Fastener Selection Guide

Fastener Size	Belt Thickness Range		For Belts with Mechanical Fastener Ratings Up To:		Recommended Minimum Pulley Diameter <i>(Operating Tension 75% -100% of Belt Rating)</i>	
	in.	mm	P.I.W.	kN/m	in.	mm
375X	1/4 - 13/32	6 - 11	190	33	6	150
550	1/4 - 5/8	6 - 16	300	52	9	225

Flexco®

Flexco® Bolt Hinged Fastener System

“J” Carton Complete Fastener Joint

Each “J” carton includes one complete belt joint for belt widths from 12" (300 mm) to 60" (1500 mm). Each carton includes:

- 2 Fastener Strips
- 1 Hinge Pin
- Filler Tubing
- 1 Gauge Pin
- 2 Hinge Pin Washers
- Required Piloted Bolts, Nuts, and Clips



375X Fasteners

Belt Width		Ordering Number			
		NC Steel Joint with Nylon Covered Steel Cable *	NCS Steel Joint with Nylon Covered Stainless Cable *	SC Steel Joint with Bare Steel Cable *	SSC Stainless Joint with Bare Stainless Cable **
in.	mm				
18	450	375XJ18NC	375XJ18NCS		
24	600	375XJ24NC	375XJ24NCS	375XJ24SC	375XSJ24SSC
30	750	375XJ30NC	375XJ30NCS		375XSJ30SSC
36	900	375XJ36NC	375XJ36NCS	375XJ36SC	375XSJ36SSC
42	1050	375XJ42NC	375XJ42NCS		375XSJ42SSC
48	1200	375XJ48NC	375XJ48NCS	375XJ48SC	375XSJ48SSC
60	1500	375XJ60NC			375XSJ60SSC

550 Fasteners

Belt Width		Ordering Number			
		NC Steel Joint with Nylon Covered Steel Cable *	NCS Steel Joint with Nylon Covered Stainless Cable *	SC Steel Joint with Bare Steel Cable *	SSC Steel Joint with Bare Stainless Cable **
in.	mm				
18	450	550J18NC			
24	600	550J24NC	550J24NCS	550J24SC	550J24SSC
30	750	550J30NC	550J30NCS	550J30SC	550J30SSC
36	900	550J36NC	550J36NCS	550J36SC	550J36SSC
42	1050	550J42NC	550J42NCS	550J42SC	550J42SSC
48	1200	550J48NC	550J48NCS	550J48SC	550J48SSC
60	1500	550J60NC			

* “J” CARTON – Continuous Strip w/Steel Nuts & Bolts

** “J” CARTON – Continuous Strip w/Stainless Nuts & Bolts

For additional Bolt Hinged offerings, please contact Flexco or your local Flexco distributor.

Flexco® Bolt Hinged Fastener System

Extra Hinge Pins

For 375X and 550

Belt Width		Ordering Number							
		NC (1/4" dia.) Nylon Covered Steel Cable		NCS (1/4" dia.) Nylon Covered Stainless Cable*		SC (1/4" dia.) Bare Steel Cable		SSC (7/32" dia.) Bare Stainless Cable*	
in.	mm	Each (One Pin)	Package (Ten Pins)	Each (One Pin)	Package (Ten Pins)	Each (One Pin)	Package (Ten Pins)	Each (One Pin)	Package (Ten Pins)
18	450	NC-18-1	NC-18		NCS-18				
24	600	NC-24-1	NC-24	NCS-24-1	NCS-24	SC-24-1	SC-24	SSC-24-1	SSC-24
30	750	NC-30-1	NC-30	NCS-30-1	NCS-30	SC-30-1	SC-30	SSC-30-1	SSC-30
36	900	NC-36-1	NC-36	NCS-36-1	NCS-36	SC-36-1	SC-36	SSC-36-1	SSC-36
42	1050	NC-42-1	NC-42	NCS-42-1	NCS-42	SC-42-1	SC-42	SSC-42-1	SSC-42
48	1200	NC-48-1	NC-48	NCS-48-1	NCS-48	SC-48-1	SC-48	SSC-48-1	SSC-48
60	1500	NC-60-1	NC-60	NCS-60-1	NCS-60				

* 300 Series

NC – Nylon Covered Steel Cable

Nylon covering reduces corrosion and simplifies hinge pin insertion.

SC – Bare Steel Cable

Recommended for abrasive or gritty material conveyance.

NCS – Nylon Covered Stainless Steel Cable

For greater corrosion resistance.

SSC – Bare 300 Series Stainless Steel Cable

For conditions where corrosion attacks ordinary steel pins.

Extra piloted bolts and nuts

Replacement piloted bolts and nuts are packaged separately, 100 per box.



Extra Piloted Bolts

For Fastener Number	Ordering Number	
	Steel	Stainless – 300 Series
375X	20398	20400
550	20399	20400

Extra Nuts

For Fastener Number	Ordering Number	
	Steel	Stainless – 300 Series
375X	20380	20381*
550	20380	20381*

* Slotted Nuts

Plastic filler tubing reduces sifting

Flexco Plastic Filler Tubing is furnished in all “J” cartons, and keeps sifting of fine materials through the hinged joint to a minimum. It is included with every “J” carton and is sold by the 100-foot reel.

Filler Tubing

Description	Qty.	Ordering Number
375X / 550	100'/Pkg.	30894



Flexco® Bolt Hinged Installation Tools and Supplies

The only tools needed for Bolt Hinged fastener installation are the portable hand tools or power tools and the Flexco® Bolt Hinged Curved Templet described here.

Hand Installation Tools

Description	For Fastener Number	Ordering Number
Punch	375X & 550	P1P
Boring Bit	375X & 550	B1B
Wrench	375X & 550	100*
		S1S**

* For use with Steel No. 375X or Steel No. 550 nuts.
 ** For use with Stainless No. 375X or Stainless No. 550 nuts.

Power Installation Tools

Description	For Fastener Number	Ordering Number
Power Punch	375X & 550	HP1
Power Boring Bit	375X & 550	HB1
Power Wrench	375X & 550	H100*
		HW1**
Quick Change Chuck	375X & 550	5552

* For use with Steel No. 375X or Steel No. 550 nuts.
 ** For use with Stainless No. 375X or Stainless No. 550 nuts.



Hand Tools



Power Tools

Bolt Breaker

Description	For Fastener Number	Ordering Number
Bolt Breaker (Two Per Package)	1, 140, 190 & RP1	110
	1-1/2, 2, 2-1/4 & RP2	112
	2-1/2 & 3	113



Bolt Breaker

Curved Templets

Our specially designed curved templet ensures accurate placement of punched or drilled holes. Using the templet also ensures a precise concave cut to provide uniform tension across full belt end and minimize the potential for splice edge failure.

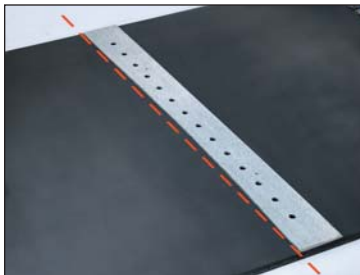

Curved Templets

Belt Width		Ordering Number	
in.	mm	375X	550
18	450	375X-18	518
24	600	375X-24	524
30	750	375X-30	530
36	900	375X-36	536
42	1050	375X-42	542
48	1200	375X-48	548
60	1500	375X-60	560

Australia: 61-2-9680-3322 • England: 44-1457-891000 • Germany: 49-7428-9406-0
 Mexico: 52-55-5674-5326 • New Zealand: 64-9-415-4488 • Republic of South Africa: 27-11-974-2771

© 2003 Flexible Steel Lacing Company. 7/03, Part#X0745
 Flexco® is a registered trademark of Flexible Steel Lacing Company.



Flexible Steel Lacing Company
 2525 Wisconsin Avenue
 Downers Grove, IL 60515-4200 U.S.A.
 Telephone: (630) 971-0150
 Fax: (630) 971-1180
 E-mail: advertising@flexco.com
 Visit our Web site at: www.flexco.com



Flexco® SR™ Rivet Hinged Fastener System

RH240

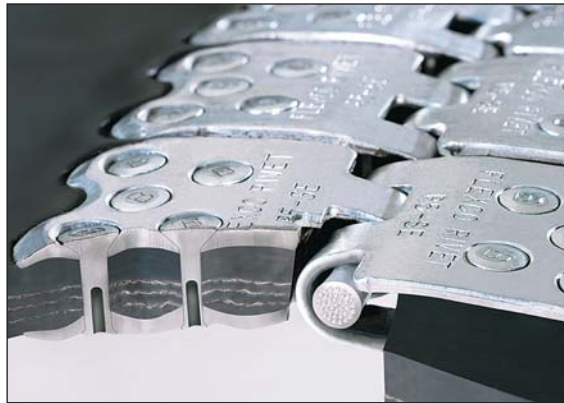

Scalloped Edge™



Viewport

- Lower fastener profile extends belt splice life.
- Less effort required for installation.
- Reduced maintenance costs.
- Viewport assures proper installation alignment.

The Flexco® SR™ Scalloped Edge™ fastener features a low profile that significantly reduces the fastener's exposure to cleaner blades, skirt rubber, and return idlers. Reduced wear and tear on the fastener extends the life of the splice to maximize belt availability and to help keep productivity on a roll.

Improved performance

Designed for rubber plied and PVC solid woven belting, and for worn belts unfit for vulcanized splices, the Flexco SR fastener features a patented Scalloped Edge design. The scalloped design contributes to improved fastener profile resulting in increased compatibility with belt cleaners and improved cleaner-tip wear. The staggered rivet pattern also provides maximum holding ability by allowing the rivets to pass between the carcass fibers without damaging them.

A built-in viewport simplifies fastener positioning. And self-setting rivets are installed from the top side of the belt for faster installation.

Market applications

- Coal
- Wood Processing
- Asphalt Plants
- Construction and Road Equipment

Flexco® SR™ Scalloped Edge™ Fastener Selection Guide

Fastener Size	Belt Thickness Range		For Belts with Mechanical Fastener Ratings Up To:		Recommended Minimum Pulley Diameter (Operating Tension 75%-100% of Belt Rating)	
	in.	mm	PI.W.	kN/m	in.	mm
R2	1/8- 3/8	3- 10	330	60	5	125
R5	7/32- 7/16	6- 11	450	79	9	230
R5-1/2	5/16- 19/32	8- 15	650	114	12	300
R6	13/32- 11/16	10.5- 17	800	140	18	450
RAR6LP	5/16- 23/32	8- 18	800	140	18	450
RAR8	13/32- 11/16	10.5- 17	1500	263	18	450

FLEXGO®

Flexco® Rivet Hinged Fastener System

Fasteners

Use the charts below to match the Flexco® SR™ Scalloped Edge™ fasteners to your needs. Find the fastener metal type required for your application. Then choose the ordering number that corresponds to your belt's width.

Flexco® R2 (Two fastener strips per package)

Belt Width		Ordering Number		Rivets Required For One Joint
in.	mm	Steel	Stainless 300 Series	
12	300	R2-12/300	R2S-12/300	24
18	450	R2-18/450	R2S-18/450	40
24	600	R2-24/600	R2S-24/600	52
26	650			
30	750	R2-30/750	R2S-30/750	64
36	900	R2-36/900	R2S-36/900	80
42	1050	R2-42/1050	R2S-42/1050	92
48	1200	R2-48/1200	R2S-48/1200	108
54	1350	R2-54/1350	R2S-54/1350	120
60	1500	R2-60/1500	R2S-60/1500	136
72	1800			

Flexco® R5 (Two fastener strips per package)

Belt Width		Ordering Number			Rivets Required For One Joint
in.	mm	Steel	Stainless 300 Series	RustAlloy® 400 Series SS	
		R5-SE-18/450	R5S-SE-18/450		100
		R5-SE-24/600	R5S-SE-24/600	RAR5-SE-24/600	130
		R5-SE-26/650		RAR5-SE-26/650	140
		R5-SE-30/750	R5S-SE-30/750	RAR5-SE-30/750	160
		R5-SE-36/900	R5S-SE-36/900	RAR5-SE-36/900	200
		R5-SE-42/1050	R5S-SE-42/1050	RAR5-SE-42/1050	230
		R5-SE-48/1200	R5S-SE-48/1200	RAR5-SE-48/1200	270
		R5-SE-54/1350		RAR5-SE-54/1350	300
		R5-SE-60/1500	R5S-SE-60/1500	RAR5-SE-60/1500	340
		R5-SE-72/1800			410

Flexco® R5-1/2 (Two fastener strips per package)

Belt Width		Ordering Number		Rivets Required For One Joint
in.	mm	Steel	RustAlloy® 400 Series SS	
18	450	R5-1/2-SE-18/450		100
24	600	R5-1/2-SE-24/600	RAR5-1/2-SE-24/600	130
30	750	R5-1/2-SE-30/750	RAR5-1/2-SE-30/750	160
36	900	R5-1/2-SE-36/900	RAR5-1/2-SE-36/900	200
42	1050	R5-1/2-SE-42/1050	RAR5-1/2-SE-42/1050	230
48	1200	R5-1/2-SE-48/1200	RAR5-1/2-SE-48/1200	270
54	1350	R5-1/2-SE-54/1350	RAR5-1/2-SE-54/1350	300
60	1500	R5-1/2-SE-60/1500	RAR5-1/2-SE-60/1500	340
72	1800	R5-1/2-SE-72/1800	RAR5-1/2-SE-72/1800	410
84	2130			

Flexco® R6 and RAR6LP Low Profile (Two fastener strips per package)

Belt Width		Ordering Number			Rivets Required For One Joint
in.	mm	Steel	RustAlloy® 400 Series SS	RustAlloy® Low Profile 400 Series SS	
					130
		R6-SE-30/750			160
		R6-SE-36/900			200
		R6-SE-42/1050	RAR6-SE-42/1050	RAR6LP-SE-42/1050	230
		R6-SE-48/1200	RAR6-SE-48/1200	RAR6LP-SE-48/1200	270
		R6-SE-54/1350	RAR6-SE-54/1350	RAR6LP-SE-54/1350	300
		R6-SE-60/1500	RAR6-SE-60/1500	RAR6LP-SE-60/1500	340
		R6-SE-72/1800	RAR6-SE-72/1800	RAR6LP-SE-72/1800	410
		R6-SE-84/2130	RAR6-SE-84/2130	RAR6LP-SE-84/2130	480

Flexco® R5 MegAlloy®

(Two fastener strips per package)

R5 MegAlloy fasteners are supplied as 4 plate strips and are packaged 10 strips per box. Enough fasteners to splice a 36" (900mm) belt.



Ordering Number
R5MA-SE

Flexco® RAR8

(Two fastener strips per package)

Belt Width		Ordering Number
in.	mm	RustAlloy® 400 Series SS
48	1200	RAR8-SE-48/1200
54	1350	RAR8-SE-54/1350
60	1500	RAR8-SE-60/1500
72	1800	RAR8-SE-72/1800
84	2130	RAR8-SE-84/2130

Flexco® Rivet Hinged Fastener System

Hinge Pins

A wide selection makes it easy to match pins to the needs of the application. Selection ranges from bare steel cable to nylon-covered armored cable.

For R2 and R5

Belt Width		Ordering Number									
		AC (1/4" dia.) Bare Armored Cable		ACS (17/64" dia.) Bare Armored Stainless Cable		NAC (1/4" dia.) Nylon Covered Armored Cable		NC (1/4" dia.) Nylon Covered Steel Cable		NCS (1/4" dia.) Nylon Covered Stainless Cable*	
in.	mm	Each (One Pin)	Package (Ten Pins)	Each (One Pin)	Package (Ten Pins)	Each (One Pin)	Package (Ten Pins)	Each (One Pin)	Package (Ten Pins)	Each (One Pin)	Package (Ten Pins)
12	300							NC-12-1			
18	450	AC-18-1	AC-18			NAC-18-1	NAC-18	NC-18-1	NC-18		
24	600	AC-24-1	AC-24			NAC-24-1	NAC-24	NC-24-1	NC-24	NCS-24-1	NCS-24
30	750	AC-30-1	AC-30	ACS-30-1	ACS-30	NAC-30-1	NAC-30	NC-30-1	NC-30	NCS-30-1	NCS-30
36	900	AC-36-1	AC-36	ACS-36-1	ACS-36	NAC-36-1	NAC-36	NC-36-1	NC-36	NCS-36-1	NCS-36
42	1050	AC-42-1	AC-42	ACS-42-1	ACS-42	NAC-42-1	NAC-42	NC-42-1	NC-42	NCS-42-1	NCS-42
48	1200	AC-48-1	AC-48	ACS-48-1	ACS-48	NAC-48-1	NAC-48	NC-48-1	NC-48	NCS-48-1	NCS-48
54	1350	AC-54-1		ACS-54-1	ACS-54	NAC-54-1		NC-54-1	NC-54	NCS-54-1	NCS-54
60	1500	AC-60-1		ACS-60-1	ACS-60	NAC-60-1		NC-60-1	NC-60	NCS-60-1	NCS-60
72	1800	AC-72-1		ACS-72-1	ACS-72	NAC-72-1		NC-72-1	NC-72	NCS-72-1	

*300 Series

For R2 and R5

Belt Width		Ordering Number			
		SC (1/4" dia.) Bare Steel Cable		SSC (7/32" dia.) Bare Stainless Cable*	
in.	mm	Each (One Pin)	Package (Ten Pins)	Each (One Pin)	Package (Ten Pins)
18	450		SC-18		SSC-18
24	600	SC-24-1	SC-24	SSC-24-1	SSC-24
30	750	SC-30-1	SC-30	SSC-30-1	SSC-30
36	900	SC-36-1	SC-36	SSC-36-1	SSC-36
38	950				
42	1050	SC-42-1	SC-42	SSC-42-1	SSC-42
48	1200	SC-48-1	SC-48	SSC-48-1	SSC-48
54	1350	SC-54-1	SC-54	SSC-54-1	SSC-54
60	1500	SC-60-1	SC-60	SSC-60-1	SSC-60
72	1800	SC-72-1		SSC-72-1	

*300 Series

For R5

Belt Width		Ordering Number			
		SC932 (9/32" dia.) Bare Steel Cable		SSC932 (9/32" dia.) Bare Stainless Cable*	
in.	mm	Each (One Pin)	Package (Ten Pins)	Each (One Pin)	Package (Ten Pins)
18	450	SC932-18-1		SSC932-18-1	
24	600	SC932-24-1		SSC932-24-1	
30	750	SC932-30-1	SC932-30	SSC932-30-1	SSC932-30
36	900	SC932-36-1	SC932-36	SSC932-36-1	SSC932-36
38	950	SC932-38-1	SC932-38	SSC932-38-1	SSC932-38
42	1050	SC932-42-1	SC932-42	SSC932-42-1	SSC932-42
48	1200	SC932-48-1	SC932-48	SSC932-48-1	SSC932-48
54	1350	SC932-54-1	SC932-54	SSC932-54-1	SSC932-54
60	1500	SC932-60-1	SC932-60	SSC932-60-1	SSC932-60
72	1800	SC932-72-1		SSC932-72-1	

*300 Series

For R5-1/2, R6, RAR6LP

Belt Width		Ordering Number			
		AC6 (3/8" dia.) Bare Armored Steel Cable		SC6 (23/64" dia.) Bare Steel Cable*	
in.	mm	Each (One Pin)	Package (Ten Pins)	Each (One Pin)	Package (Ten Pins)
24	600	AC6-24-1	AC6-24		
30	750	AC6-30-1	AC6-30		
36	900	AC6-36-1	AC6-36		SC6-36
38	950	AC6-38-1	AC6-38	SC6-38-1	SC6-38
42	1050	AC6-42-1	AC6-42	SC6-42-1	SC6-42
48	1200	AC6-48-1	AC6-48	SC6-48-1	SC6-48
54	1350	AC6-54-1	AC6-54	SC6-54-1	SC6-54
60	1500	AC6-60-1	AC6-60	SC6-60-1	SC6-60
72	1800	AC6-72-1	AC6-72	SC6-72-1	SC6-72

For R5-1/2, R6, RAR6LP, RAR8

Ordering Number	
ACS6 (3/8" dia.) Bare Armored Stainless Cable*	
Each (One Pin)	Package (Ten Pins)
ACS6-36/900-1	ACS6-36/900
ACS6-42-1	ACS6-42
ACS6-48-1	ACS6-48
ACS6-54-1	ACS6-54
ACS6-60-1	ACS6-60
ACS6-72-1	ACS6-72

For R6, RAR6LP

Ordering Number	
NAC6 (13/32" dia.) Nylon Covered Armored Cable	
Each (One Pin)	Package (Ten Pins)
NAC6-24-1	NAC6-24
NAC6-30-1	NAC6-30
NAC6-36-1	NAC6-36
NAC6-38-1	NAC6-38
NAC6-42-1	NAC6-42
NAC6-48-1	NAC6-48
NAC6-54-1	NAC6-54
NAC6-60-1	NAC6-60
NAC6-72-1	NAC6-72

*300 Series

Flexco® Rivet Hinged Fastener System

Rivets

Rivets are available in either steel or stainless steel. Rivets are packaged 250 rivets per box. SRAA, SRA, SRB, and SRC rivets are also available in 100-count packages. Bulk packs of 2,000 rivets are also available in reusable plastic buckets.



Rivet Selection Chart

Fastener Size	Belt Thickness Range		Rivet Size
	in.	mm	
R2	1/8- 7/32	3- 6	SRAA
	3/16- 5/16	4- 8	SRA
	9/32- 3/8	7- 10	SRB
R5	7/32- 5/16	6- 8	SRA
	9/32- 3/8	7- 10	SRB
	11/32- 7/16	9- 11	SRC
	13/32- 7/16	10.5- 11	SRC/D
R5-1/2 & RAR6LP	5/16- 11/32	8- 9	SRB
	5/16- 13/32	8- 10.5	SRC
	3/8- 15/32	10- 12	SRC/D
	7/16- 17/32	11- 13.5	SRD
	1/2- 19/32	13- 15	SRE
	9/16- 21/32	14- 16.5	SRF*
R6	5/8- 23/32	16- 18	SRG*
	11/32- 7/16	9- 11	SRC/D
	13/32- 1/2	10.5- 13	SRD
	15/32- 9/16	12- 14	SRE
	17/32- 5/8	13.5- 16	SRF
RAR8	19/32- 11/16	15- 17	SRG
	13/32- 7/16	10.5- 11	SRC/D
	13/32- 1/2	10.5- 13	SRD
	15/32- 9/16	12- 14	SRE
	17/32- 5/8	13.5- 16	SRF
	19/32- 11/16	15- 17	SRG

*Applies to RAR6LP only

Rivets

Self-Setting Pre-Assembled With Pilot Nails

Ordering Number	
Steel	Stainless Type 430
Box (100 Rivets)	
SRAA-100	
SRA-100	
SRB-100	
SRC-100	
Box (250 Rivets)	
SRAA	SRAA-S
SRA	SRA-S
SRB	SRB-S
SRC	SRC-S
SRC/D	SRC/D-S
SRD	SRD-S
SRE	SRE-S
SRF	SRF-S
SRG	SRG-S
Bucket (2000 Rivets)	
SRA-2M	SRA-S-2M
SRB-2M	SRB-S-2M
SRC-2M	SRC-S-2M
SRC/D-2M	SRC/D-S-2M
SRD-2M	SRD-S-2M
SRE-2M	SRE-S-2M
SRF-2M	SRF-S-2M
SRG-2M	SRG-S-2M

Installation Tools

For easy-to-use, portable tools that make multiple rivet driving simple and fast, choose the MSRT or MSRT8. For single rivet driving, choose the SRTA tool and for easy installation of Flexco R2 fastener, the R2T tool is lightweight, portable and economically priced.

MSRT Applicator Complete

(Installs R5, R5-1/2, R6 & RAR6 fasteners only)

Belt Width		Ordering Number
in.	mm	
30	750	MSRT-30
36	900	MSRT-36
42	1050	MSRT-42
48	1200	MSRT-48
60	1500	MSRT-60
72	1800	MSRT-72
84	2130	MSRT-84

MSRT8 Applicator Complete

(Installs R6, RAR6 & RAR8 fasteners only)

Belt Width		Ordering Number
in.	mm	
48	1200	MSRT8-48
60	1500	MSRT8-60
72	1800	MSRT8-72
84	2130	MSRT8-84

SRTA Applicator Complete

(Includes one SR-50 Driver Tool)

Belt Width		Ordering Number
in.	mm	
30	750	SRTA-30
36	900	SRTA-36
42	1050	SRTA-42
48	1200	SRTA-48
60	1500	SRTA-60
72	1800	SRTA-72
84	2130	SRTA-84

R2T Applicator Tool

Tool Size		Ordering Number
in.	mm	
12	300	R2T



Flexible Steel Lacing Company

2525 Wisconsin Avenue
Downers Grove, IL 60515-4200 U.S.A.

Telephone: (630) 971-0150

Fax: (630) 971-1180

E-mail: advertising@flexco.com

Visit our Web site at: www.flexco.com



Australia: 61-2-9680-3322 • England: 44-1457-891000 • Germany: 49-7428-9406-0
Mexico: 52-55-5674-5326 • New Zealand: 64-9-415-4488 • Republic of South Africa: 27-11-974-2771

Squared Belt Ends Increase Belt Life – Reduce Maintenance Costs



Tension is distributed evenly across the entire width of a properly squared belt, minimizing problems associated with belt mistracking and premature splice wear.

One of the best ways to maximize mechanical fastener splice life is to make sure both belt ends are properly squared prior to fastener installation. By performing this simple procedure you can be sure fasteners will last significantly longer. Problems associated with belt mistracking will also be reduced, resulting in less maintenance downtime.

Why a properly squared belt is important

A properly squared belt will distribute tension evenly across the entire length of the mechanical splice. Belts will track straighter, thus minimizing problems associated with uneven tension. These problems include:

- Premature belt and splice wear when mistracking belts come in contact with the conveyor structure
- Load spillage and cleanup resulting from load shift from belt center to belt edge
- Fastener pullout and uneven top plate wear

Flexco Belt Cutters

A selection of specially engineered belt cutters from Flexco makes it easy to achieve the precise cut required for proper belt squaring. Contact your Flexco distributor for more information.



Squaring a belt end requires only common measuring tools and a Flexco belt cutter.

Flexco

How to Properly Square a Belt End

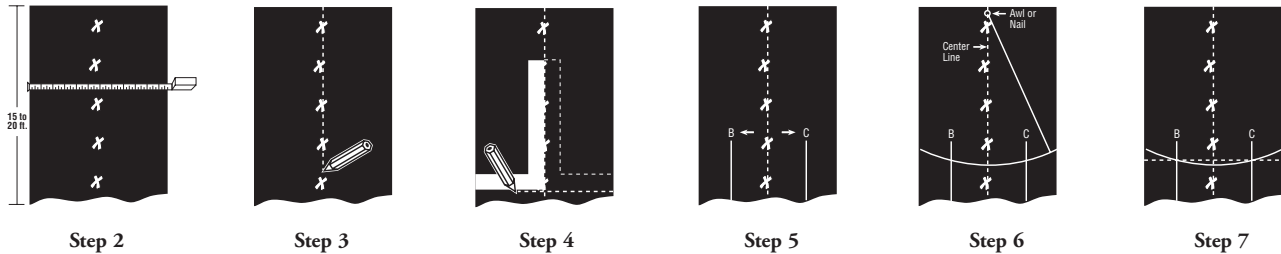

The following simple steps will help ensure that a belt is properly squared prior to mechanical fastener installation.

Step 1. Prior to any work on your conveyors, be certain that the power has been turned off and that the belt is “locked out.”

Step 2. Measure the belt width and establish center points at intervals of 3 to 5 feet (1 to 1.5 m). (A distance of 15 to 20 feet [4.5 to 6 m] back from the intended splice area is recommended.)

Step 3. Using either a steel straight edge or a chalk line, mark the average center line through the points measured in Step 2.

Step 4. Using a square, draw a line perpendicular to your average center line across the belt width.

Step 5. For even greater accuracy in preparing your squaring line – and on belts with worn edges – after completion of Step 3, mark two lines (B & C) equal distance from the center line in the area where the splice will be installed. Lines B & C must be parallel to the center line.

Step 6. Measure back from the intended splice area to a distance approximately equal to three times the belt width. At this point drive a nail or an awl on the center line. Using the nail or awl as a pivot point, swing an arc, marking the belt across its entire width.

Step 7. Where this arc intersects the two smaller lines (B & C) marked parallel to the belt center line, align a steel straight edge through these points and trace the line across the width of the belt. The resulting line is the true square.

Step 8. Cut the belt at this line using one of the specially engineered belt cutters from Flexco.

Step 9. Repeat Steps 1-8 on the other belt end.

Australia: 61-2-9680-3322 • England: 44-1457-891000 • Germany: 49-7428-9406-0
Mexico: 52-55-5674-5326 • New Zealand: 64-9-415-4488 • Republic of South Africa: 27-11-974-2771

© 2003 Flexible Steel Lacing Company. 7/03, Part#X0755
Flexco® is a registered trademark of Flexible Steel Lacing Company.



Flexible Steel Lacing Company
2525 Wisconsin Avenue
Downers Grove, IL 60515-4200 U.S.A.
Telephone: (630) 971-0150
Fax: (630) 971-1180
E-mail: advertising@flexco.com
Visit our Web site at: www.flexco.com



For Clean, Simple Cuts in Either Direction: Belt Cutters from Flexco

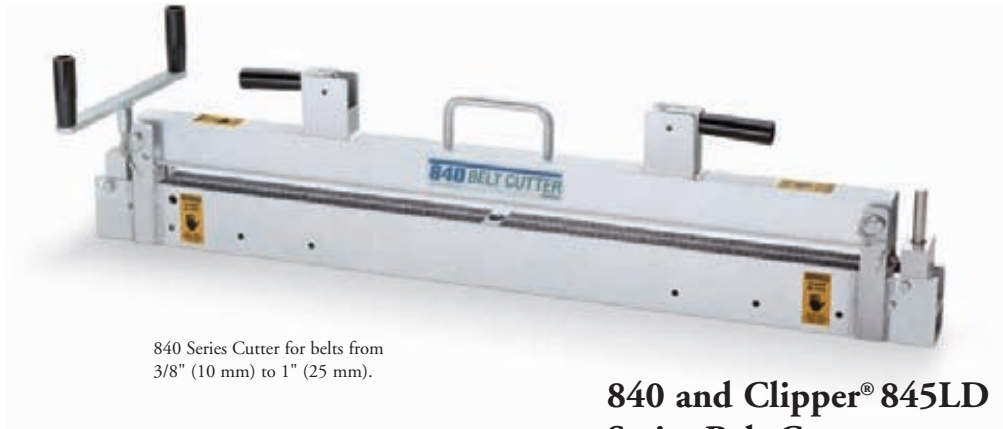

840 Series Cutter for belts from 3/8" (10 mm) to 1" (25 mm).

840 and Clipper® 845LD Series Belt Cutters

Select an easy-to-use belt cutter ideally sized to the thickness and width of your belt. Both the 840 Series Belt Cutter (for belts from 3/8" [10 mm] to 1" [25 mm]) and the Clipper® 845LD Belt Cutter (for belts up to 1/2" [12 mm]) feature a special flat-top blade design for added safety. Plus, both can be chain-driven from either end of the cutter to simplify clean cuts in both directions.

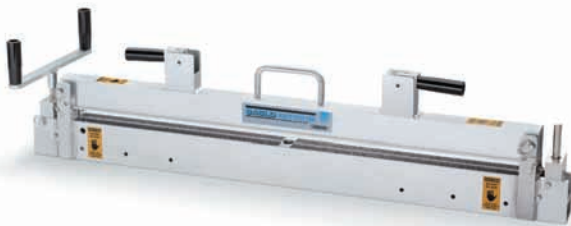

Clipper® 845LD Cutter for belts up to 1/2" (12 mm).

Removable clamp bars hold belts securely and can be hinged and lifted from either end to simplify routine operation and maintenance. And both cutters feature a chain tensioner for fast field adjustment, and a specially designed drive wrench that also adjusts chain tensioner bolts.

Alligator® 300 Series Belt Cutter

For belts up to 1-1/8" (28 mm) thick, the Alligator® 300 Series belt cutter features a double-edged blade that cuts cleanly in either direction. Also available with an extra-long blade for belts up to 1-9/16" (39 mm) thick.



Alligator® 300 Series Cutter for belts up to 1-9/16" (39 mm).

Flexco

Belt Cutters from Flexco

840 Series Belt Cutter

Belt widths up to:		Description	Ordering Number
in.	mm		
36	900	36" Belt Cutter	840836
48	1200	48" Belt Cutter	840848
60	1500	60" Belt Cutter	840860
72	1800	72" Belt Cutter	840872
84	2100	84" Belt Cutter	840884
Replacement Parts			
Wrench Assembly (handle)			840WA
Extra Blade (with screw) 1" (25 mm)			840-1CB
Optional Squaring Device			840SD

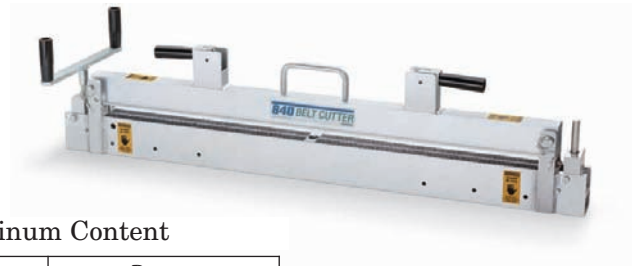

Aluminum Content

Aluminum Alloy Type	Percent	
	Mg Magnesium	Ti Titanium
6061	1.00%	0%

Clipper® 845LD Belt Cutter

Belt widths up to:		Description	Ordering Number
in.	mm		
36	900	36" Belt Cutter	845836LD
48	1200	48" Belt Cutter	845848LD
60	1500	60" Belt Cutter	845860LD
72	1800	72" Belt Cutter	845872LD
Replacement Parts			
Wrench Assembly (handle)			840WA
Cutter Blade Kit			845-CBK
Optional Squaring Device			840SD

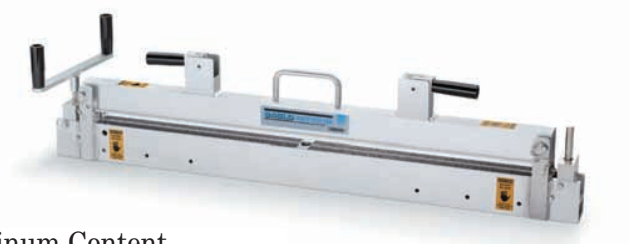

Aluminum Content

Aluminum Alloy Type	Percent	
	Mg Magnesium	Ti Titanium
6061	1.00%	0%

Alligator® 300 Series Belt Cutter

Cutter Complete

Belt Width		Ordering Number
in.	mm	
12	300	300312
18	450	300318
24	600	300324
30	750	300330
36	900	300336
42	1050	300342
48	1200	300348
60	1500	300360



Aluminum Content

Aluminum Alloy Type	Percent	
	Mg Magnesium	Ti Titanium
380	0.10%	0%



Flexible Steel Lacing Company
 2525 Wisconsin Avenue
 Downers Grove, IL 60515-4200 U.S.A.
 Telephone: (630) 971-0150
 Fax: (630) 971-1180
 E-mail: advertising@flexco.com
 Visit our Web site at: www.flexco.com



Australia: 61-2-9680-3322 • England: 44-1274-600-942 • Germany: 49-7428-9406-0
 Mexico: 52-55-5674-5326 • South Africa: 27-11-608-4180

© 2007 Flexible Steel Lacing Company. 7/01, Part#X0756
 Alligator® and Clipper® are registered trademarks of Flexible Steel Lacing Company.

FSK™ Belt Skiver



Portable, lightweight, and easy to carry, the FSK™ Belt Skiver adjusts easily to the precise cutting depth you need. The FSK Belt Skiver is compact, so it is easy to use anywhere on the job site – even in cramped operating environments.

For use on rubber-covered belts with top covers of 3/16" (4.5 mm) or more. Provides skives from 1/16" (1.5 mm) to 3/8" (10 mm) deep in a single pass. Deeper skives can be achieved with multiple passes. Can also be used on most worn or damaged belt surfaces.

Flexco® FSK™ Belt Skiver

Description	Ordering Number
Skiver Complete	FSK-1

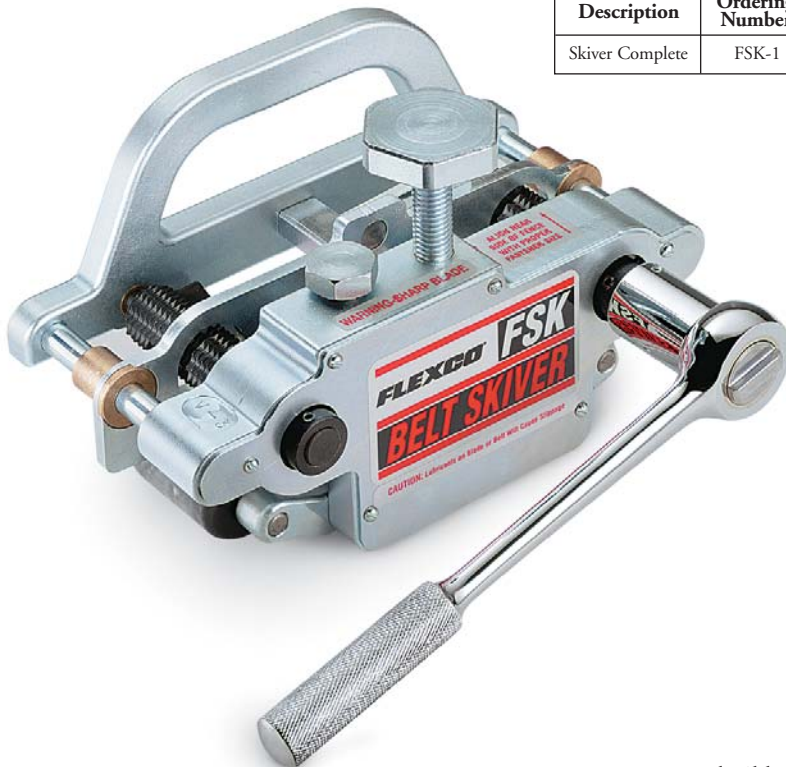

Flexible Steel Lacing Company
 2525 Wisconsin Avenue
 Downers Grove, IL 60515-4200 U.S.A.
 Telephone: (630) 971-0150
 Fax: (630) 971-1180
 E-mail: advertising@flexco.com
 Visit our Web site at: www.flexco.com



Australia: 61-2-9680-3322 • England: 44-1457-891000 • Germany: 49-7428-9406-0
 Mexico: 52-55-5674-5326 • New Zealand: 64-9-415-4488 • Republic of South Africa: 27-11-974-2771

© 2003 Flexible Steel Lacing Company. 7/03, Part#X0722
 Flexco® is a registered trademark and FSK™ is a trademark of Flexible Steel Lacing Company.

FSK™

Eliminator®

Specialty Conveyor Products

Eliminator®...provides special solutions for difficult belt conveyor problems. Flexco offers time-tested and field-proven products for belt splicing, cleaning, training, and other maintenance tasks that you face daily on your conveyors. The job of cleaning your belts, especially those in tough, special applications, can be done easily and safely with Eliminator Belt Cleaning Systems. Eliminator offers a wide variety of precleaners and secondary cleaners to match your requirements, or we can specially design the cleaner to meet your needs.

If belt mistracking is a problem, turn to Flexco for the ultimate answer...the PT Max™ Belt Trainer. We can even solve problems associated with fugitive materials and transfer point spillage with our V-Plows and Flex-Lok™ Skirt Clamps. Also, we have a complete line of belt cleaner accessory products and genuine replacement parts for all of our products.

Add the industry's most trusted line of mechanical fastening systems and you have everything your company needs to maintain top productivity on your belt conveyor applications.

For more information or product specifications, check the Flexco web site or call us at 1-800-541-8028.

Flexible Steel Lacing Company
2525 Wisconsin Avenue
Downers Grove, IL 60515-4200 U.S.A.
Phone: 800-541-8028
Web site: www.flexco.com



©2005 Flexible Steel Lacing Company, Printed in U.S.A.
U.S. Patent Nos. 5,358,098; 6,823,983; 6,279,727; 6,926,133; D482,508S
Eliminator®, Flexco®, H-Type®, P-Type®, U-Type®, R-Type®, Flexco®, Far-Pul®,
and HD® are registered trademarks, and ConShear®, PT Max®, Flex-Lok®, Flex-
Lifter®, SR®, VP®, and FSK® are trademarks of Flexible Steel Lacing Company.
Belle Banne® is a registered trademark of Nippon Tsusho Co., Ltd.
For Reorder: Item Code X1387 Revised 1/08

Distributed by:

Specialty Belt Cleaners

For Reversing Belts

For superior cleaning on reversing belts, choose either the H-Type® Precleaner or the R-Type® Secondary Cleaner. Both are ideal for shuttle conveyors, conveyors that roll back, or for trippers and stackers that run the belt in either direction.

- **H-Type** - simply mount a unit on both pulleys. The XF2-Tip can be used for mechanically fastened belts or the V-Tip for vulcanized belts.
- **R-Type** - combines metal blades for high cleaning performance and unique, two-way cushions that maintain constant blade-to-belt pressure while the belt is running in either direction.

For Chevron Belts

Chevron, cleated and raised rib belts present a special problem for efficient cleaning.

Flexco's Chevron Belt Cleaner takes a new approach to cleaning these problem belts. Hundreds of rubber fingers create a rotary cleaning action that easily flicks carryback off the belt. Now there is a better solution for wet sand belts, wood chip belts and other raised top or grooved belts.

- Free-rotating. Works only when the belt runs.
- Self-cleaning. Finger length, spacing, and the rotary action allows the carryback to fall free instead of clogging.

For Specialty Applications

Eliminator® cleaners can be special ordered with stainless components or with other specialty parts. Call Customer Service at 1-800-541-8028 for pricing and delivery.

- **For Corrosive Applications** - stainless steel poles, shields or complete cleaners are available.

For Vulcanized Belts

Each of these high performance cleaners comes with the V-Tips...a proprietary tungsten carbide that combines superior cleaning efficiency with extra long wear.

Note: If temporary mechanical splices or rip repairs are put into the belt, the V-Tips must be moved away from the belt or replaced with XF2-Tips or C-Tips.

Precleaners

The H-Type® V-Tip Precleaner is the only metal blade cleaner that is designed to be mounted on the head pulley.

- **8" (200mm) Segmented Blades** - allow the cleaning tips to conform to the belt.
- **Independently Tensioned Cushions** - maintain constant blade-to-belt contact with less maintenance.
- **Spring Tensioning** - makes it easy to visually check blade tension and allows the blades to be brought back to optimal tensioning with a simple adjustment.

Secondary Belt Cleaners

Any of the models can be mounted 4" (100mm) from the transition point where the belt leaves the head pulley or anywhere down the beltline. And all feature segmented blades or springs that maintain constant blade-to-belt tension. The cleaner choices are:

- **P-Type® with V-Tips** - a blade tip angled at 90° to the belt increases the cleaning efficiency.
- **Belle Banne® U-Type® with V-Blade** - the U-shaped blade makes maximum contact with the center portion of the belt where cleaning is needed most.

Eliminator®

Specialty Conveyor Products

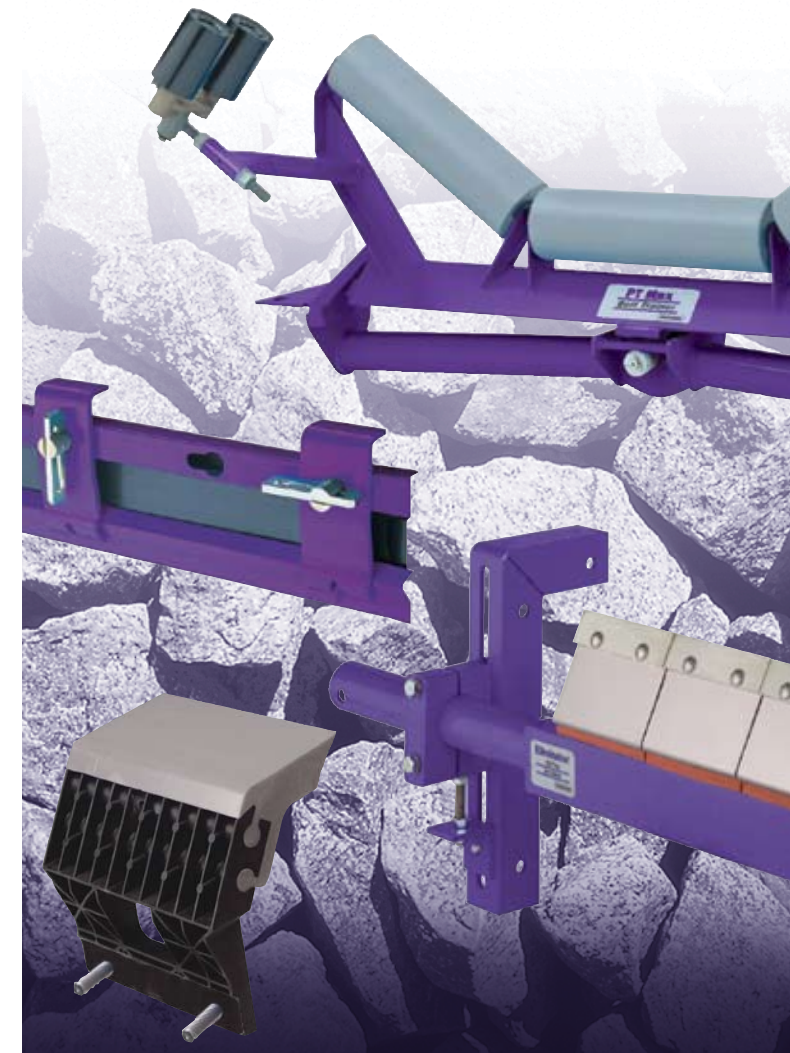

GOODYEAR
RUBBER PRODUCTS INC.

Call Toll Free: **1-866-711-4673**
WebSales@GoodyearRubberProducts.com

**We Ship
World Wide**

Cleaners for Mechanically Spliced Belts

The H-Type® XF2 Precleaner

The H-Type® Precleaner is optimally located on the head pulley to drop carryback right at the transfer point. Unlike solid-blade cleaners, it has technically engineered 8" (200mm) segmented blades to allow the cleaning tips to conform to the belt and to interface with the belt splice. Other features include:

- **Independently Tensioned Cushions** – maintain constant blade-to-belt contact for continuous cleaning.
- **Spring Tensioner** – for easy relief from passing mechanical splices and a quick return to the belt.
- **Visual Tension Inspection** – quick method to determine if the blades are at optimal cleaning tension.
- **Extended Wear Life** – specially formulated, abrasion-resistant urethane for increased blade life. 2-1/2" (63mm) of usable blade tip.



Secondary Belt Cleaners

All options feature segmented blades or springs that automatically keep the blades on the belt for consistent cleaning power. Specially formulated tungsten carbide blades work with mechanical splices and deliver the superior cleaning efficiency of a metal blade. The choices include:

- **P-Type® with C-Tips** – compact enough to fit in the transfer area and includes tips set at a non-aggressive 70° angle to quickly give relief for passing mechanical splices.
- **Belle Banne® U-Type® with C-Blade** – a patented U-shaped blade shears material off the belt. A dual-sided spring tensioner allows for continuous blade-to-belt contact.
- **R-Type® with C-Tips** – when space restrictions require installation closer to the head pulley.



For "Limited Space" Applications

A tight chute configuration or limited space on a conveyor structure may make it a problem to install a belt cleaner. A more compact cleaner is required. Here is an option:

- **P-Type® LS with C-Tips** – requires only 5-1/2" (138mm) of vertical clearance for correct installation.



For Wet, Sticky Carryback Materials

The Belle Banne® U-Type® Cleaner provides superior cleaning efficiency...especially in wet, tough, abusive applications. The patented U-shaped design allows maximum blade-to-belt contact in the center of the belt where most of the cleaning is done.

- **Tungsten Carbide Tipped Blade with a Rubber Backer** – the metal tips peel off the stubborn carryback materials and the rubber squeegees the water off.
- **Final Cleaner in a System** – teamed with an Eliminator® precleaner and in some cases another secondary cleaner, the results are unmatched for cleaning efficiency.



For High Temp Applications

High Temp Precleaners

Eliminator® High Temp Cleaners are designed to work in severe-duty, high heat applications. Now you can choose from a variety of models to select the right cleaner for your asphalt, limestone, clinker, paper mill or foundry application.

High Temp ConShear™ Precleaner

- A urethane blade designed for continuous ambient temperatures up to 275°F (135°C) and spikes to 325°F (163°C).
- Extended wear, proprietary urethane that works with mechanical fasteners.
- Visual check spring tensioner for easy maintenance.



High Temp V-Tip Precleaner

- For severe-duty applications where ambient temperatures may reach 400°F (204°C) with spikes to 450°F (232°C).
- Tungsten carbide tips for superior cleaning on vulcanized belts.
- 8" segmented blades independently tensioned for constant blade-to-belt contact.



High Temp Secondary Cleaner

- Works in ambient temperatures up to 400°F (204°C) with spikes to 450°F (232°C).
- Abrasion-resistant tungsten carbide C-Tips and



The Importance of Belt Cleaner/Fastener Interaction

For maximum carryback removal and minimum cleaner maintenance, compatibility of the belt cleaner and the mechanical fastener is critical. There is a science to the physical interaction that is often overlooked.

Consideration must be given to:

- Correct fastener and cleaner selection for the application.
- Proper installation of both the cleaner and the splice.

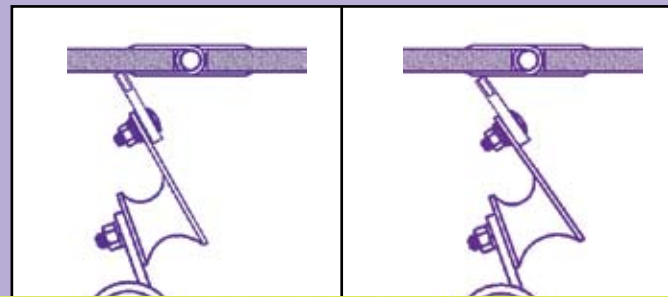

GOODYEAR
RUBBER PRODUCTS INC.

Call Toll Free: **1-866-711-4673**
WebSales@GoodyearRubberProducts.com

**We Ship
World Wide**

Conveyor Products

PT Max™ Belt Trainer

The PT Max™ is a high performance belt trainer. The patented “pivot & tilt” design delivers superior training action that makes it easy to keep even the most troublesome belts on track permanently. When a belt mistracks as little as 1/2" (13mm), the PT Max begins a pivoting action. This immediately triggers a tilting action that increases the tension in the belt on the side wandering off, and this uneven tension causes the belt to move back to center. Top side and return side models are available. Other features include:



“Pivot & Tilt”

- **Two Sensor Rollers on Each Side** – the increased belt edge surface contact reduces severe edge pressure and eliminates belt edge damage.
- **Pivot Points Will Not Freeze Up** – eliminates a common problem with conventional trainers. A unique universal bearing requires no lubrication and is guaranteed to last.



PT Max
Top Side



PT Max
Return Side

No Risk Performance Guarantee

Our PT Max™ Belt Trainer Center Bearing is guaranteed for 5 years of satisfactory service.

V-Plow

The V-Plow is a “belt cleaner” for the inside of the belt. It keeps rocks, lumps, fines and other debris from getting into the tail pulley and causing damage to the belt, splice, lagging or pulley.



- **Exclusive Blade Design** – the blade’s 20° leading edge spirals debris off the belt.
- **Self-Adjusting Blade** – the plow is installed so the blade floats on the belt and self-adjusts as it wears.
- **Unique Adjuster** – a turnbuckle-type adjuster allows the blade to be fine-tuned to the belt at installation. This means the nose of the plow is accurately positioned so it will not dig into the belt and cause damage to the belt or the plow.
- **UHMW Blade** – for long blade life and less wear and tear on the belt. Replacement blades are economical and easy to change out.
- **Easy to Install** – comes fully assembled and can be placed right into position on the conveyor. Simple step-by-step instructions are included for quick installation.
- **Versatile** – fits any conveyor structure. An optional Clamp Plate Kit is available for mounting on small channel, rope or tube structures. Can be used at the tail pulley or anywhere on the beltline where carryback is a problem.



Flex-Lok™ Skirt Clamps

Eliminating loading point spillage can be done effectively and permanently with Flex-Lok™ Skirt Clamps. These versatile skirt clamps feature an interlocking design that can be installed and readjusted by a single person. When properly installed, the skirt rubber will not rub on the belt or cause premature wear or gouge marks on the belt. Other features include:



- **Unique Wedge Pin** – skirt rubber is inserted and adjusted by simply using a non-metal hammer to unlock the self-contained wedge in the clamp pin and relocking it.
- **Anti-Vibration Clamp Pin** – the wedge in the clamp pin has one side serrated, so when the wedge is pounded into the closed position the teeth lock it in place and guard against loosening due to vibration.
- **Low Maintenance** – all parts interlock for assembly. No nuts and bolts to rust and break off.
- **Safe to Service** – all maintenance can be done safely from the sides of the conveyor.
- **Versatile** – can be used with a range of skirt rubber thicknesses from 5/16" to 1" (8 to 25mm).



Mini Flex-Lok Skirt Clamps

Mini Flex-Lok has been reduced in height to accommodate tight chute configurations and portable equipment with restricted space. Height of the mini clamp plate is 4-1/2" (113mm); the standard clamp plate is 7" (175mm). Mini Flex-Lok will handle a skirt rubber thickness range from 5/16" to 5/8" (8 to 16mm).



Standard Mini

Beltline Maintenance Tools

Flex-Lifter™

Moving a tensioned conveyor belt out of the way to do maintenance work is a tough job. And it can be dangerous if the right tools are not used. The Flex-Lifter is designed to lift tensioned belts easily and safely. It is portable and easy to place on the conveyor. The Flex-Lifter can lift top side (both troughed and flat belts) and return side belts. Each model covers a range of belt widths.



Other Flexco Maintenance Tools

Flexco® 840 Belt Cutter

Makes straight belt end cuts quickly and easily. Adjustable clamp bars hold the belt securely and a double-edged blade cuts cleanly in either direction.



FSK™ Belt Skiver

It simplifies the process of recessing fasteners by accurately and uniformly skiving the belt’s top cover. Increases belt fastener/cleaner compatibility.



Far-Pul® HD® Belt Clamps

Easy-to-use, adjustable belt clamps. Engineered for heavy-duty applications and adjustable to a variety of belt widths.



GOODYEAR
RUBBER PRODUCTS INC.

Call Toll Free: **1-866-711-4673**
WebSales@GoodyearRubberProducts.com

**We Ship
World Wide**

Belt Cleaner Accessories

Stabilizing Return Roller

An easy-to-install hold-down roller to flatten and stabilize the belt for maximum belt cleaning efficiency.

A durable Exalon HMWP roller is used for abrasion and corrosion resistance.

The universal brackets can be purchased as a kit so the user can use any return roller. Other features include:



- **Versatile and Adjustable** - The brackets are adjustable, both horizontally and vertically, to fit the requirements of most conveyor structures.
- **Compact** - an offset design accommodates varying belt-to-structure distances and requires only a 5" x 6" (125 x 150mm) space for installation.

Optional Neoprene Cushions

For oily conditions, special neoprene cushions are available for the P-Type® and R-Type® cleaners.



Optional Stainless Steel Shields

Prevents material buildup on the cleaner by deflecting carryback materials into the discharge area. Stainless steel for corrosion and wear resistance. Available for H-Type® and P-Type® cleaners.

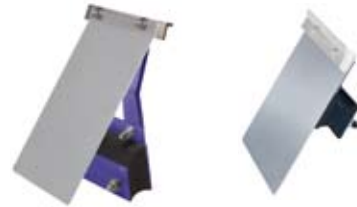

SL Tensioning Mounting Kit

Allows blade retensioning adjustments on both sides of the cleaner to be made from a single location. The kit uses cable, pulleys and mounts to put both spring tensioners on the same side of the belt. For use with H-Type, Belle Banne® U-Type® and U-Type LS belt cleaners.



Water Spray Pole Systems

Adding a limited amount of water can improve the belt cleaning performance in many applications. The water lubricates the belt, encapsulates the carryback fines and makes it easier for the cleaner blades to clean the belt.

The Spray Pole System easily attaches to the cleaner pole. Features include:

- **Spray Nozzles** - spaced on 12" (300mm) centers, each nozzle delivers .98 gallons/minute at 60 psi. Generally

Replacement Parts

Replacement Blades

All Eliminator® blades and tips are manufactured to exacting quality standards from specially formulated materials that ensure high abrasion resistance and long wear life.

Urethane Blades

- **XF2-Tip** - 8" (200mm) segmented pre-cleaner blade designed for compatibility with Flexco mechanical fasteners. A proprietary urethane formulation provides exceptional wear life and abrasion resistance.



Metal Blades

- **C-Tip** - impact-resistant tungsten carbide tip that offers the cleaning efficiency and wear life of a metal blade, but is compatible with Flexco splices.
- **V-Tip** - an exclusive tungsten carbide that provides extra-long wear life. For use with vulcanized splices only.



Other Replacement Parts

Complete lists of repair parts are available for all Eliminator belt cleaners and conveyor products.

Genuine Eliminator® Replacement Parts

For best results and continued high performance

Flexco® Belt Fasteners

Flexco® SR™ Rivet Hinged Fasteners

For demanding, heavy-duty applications, the SR™ fastener is the recognized leader in mechanical belt splicing. It has staggered, multi-point attachments and a removable hinge pin for a strong, long-lasting splice. The scalloped edge helps the belt cleaner blade ramp up and over the splice with minimal cleaning disruption.



Flexco® VP™ Bolt Solid Plate Fastener

Provides increased impact protection for the top plates and reduces fastener wear. The rubber covering offers a sift-free, sealed splice. When the VP™ is recessed into the belt it provides a smooth surface for maximum compatibility with belt cleaner blades.



Need More Information?

Visit our Web site!

www.flexco.com

- Products



GOODYEAR
RUBBER PRODUCTS INC.

Call Toll Free: **1-866-711-4673**
WebSales@GoodyearRubberProducts.com

**We Ship
World Wide**

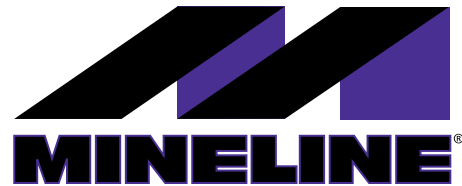

Mineline®... our mine-tough conveyor product line designed exclusively for underground and surface coal mining.

Featuring the same expert construction and easy maintenance as all our custom conveyor products, Mineline has been designed and constructed with the durability to stand up to tough mine use. Mineline belt cleaners feature oversized poles for strength, and unique tensioning options to assure consistent performance over the long haul. With routine parts replacement and occasional adjustments, Mineline products deliver years of outstanding service.

For more information, product specifications, belt cleaner recommendations or other questions, call us at 1-800-541-8028.

Flexible Steel Lacing Company
2525 Wisconsin Avenue
Downers Grove, IL 60515-4200 U.S.A.
Phone: 800-541-8028
Web site: www.flexco.com



©2004 Flexible Steel Lacing Company, Printed in U.S.A.
U.S. Patents #D482,5085, #6,823,983
Mineline® is a registered trademark, and ConShear™, TuffShear™, SuperShear™ and PowerFlex™ are trademarks of Flexible Steel Lacing Company.
For Reorder: Item Code X1320 Rev. 11/07

Distributed by:



Standard-Duty Secondary

Carbide-tough blades with self-adjusting tensioners.

MSS Standard-Duty Secondary Cleaner



- **Tough Carbide-Tipped Blades** – for long wear, efficient cleaning and compatibility with mechanical splices.
- **Rubber Cushions** – segmented design allows each blade to self-adjust to the belt independently for continuous blade-to-belt cleaning power.
- **SST Spring Tensioner** – a self-contained spring tensioning system energizes the individual cushions for constant cleaning and smooth interaction with mechanical splices.
- **Easy Maintenance** – after a quick measurement of the tension springs, a few turns on the tension nuts bring the blades back to optimal tension.
- **Compact Design** – fits into tight-clearance conveyor structures. Requires only 4 inches (100 mm) of horizontal clearance and 10 inches (250 mm) of vertical clearance for correct installation.

Heavy-Duty Secondary

Superior cleaning efficiency in demanding applications.

MHS Heavy-Duty Secondary Cleaner



- **PowerFlex™ Cushion** – patented, segmented cushion design has two tensioning elements that control independent adjustment of each blade to the belt for efficient, thorough cleaning.
- **Tough Carbide-Tipped Blades** – for long wear life, high-performance cleaning and compatibility with mechanical splices.
- **Cleans on the Head Pulley** – can be installed on the belt anywhere from the bottom of the head pulley on down the beltline.
- **SST Spring Tensioner** – provides self-adjusting tension to ensure the blades maintain continuous blade-to-belt contact.
- **Durable** – engineered with an oversized pole and heavy-duty, corrosion-resistant steel parts to endure the high-duty cycles of high-speed beltlines.

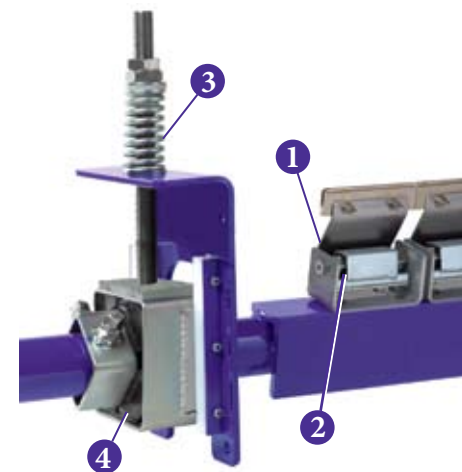

Four relief points for mechanical splices.

- **Multiple Tensioning Elements** – work together to cushion the initial impact of the splice hit and allow the blades to move quickly away from the belt until the splice passes.
- **Multiple Results** – no damage and less wear on splices and cleaner blades, and minimal cleaning disruption.

Special MHS Cleaners

- **With Air/Water Tensioner** – a secondary air/water tensioner (SAT) automatically adjusts the blade to the belt until the blade is worn out.
- **For Reversing Belts** – a



Special Secondary

For water removal and final cleaning.

MDWS DryWipe Secondary Cleaner



- **Wipes the Belt Dry** – the ConShear™ DryWipe Blade uses a pliable urethane to conform to the belt and squeegee the water off.
- **Final Cleaner in a System** – the blade is designed to be 4 inches (100 mm) wider than the nominal belt width to ensure the water is moved off the belt, even if the belt mistracks.
- **Automatic Blade Tensioning** – dual spring tensioners self-adjust the blade to the belt as it wears.
- **Works with Mechanical Splices** – the blade glides over splices and the spring tensioners dampen the impact.
- **Long Blade Life** – made from specially formulated urethane for long wear. Features a molded-in wear line that indicates when the blade needs to be replaced.
- **Use with Spray Poles** – can be mounted after a spray pole to ensure the belt is dry at a pre-selected location.



Call Toll Free: **1-866-711-4673**
WebSales@GoodyearRubberProducts.com

**We Ship
World Wide**

Standard-Duty Precleaner

Strength and efficiency at the right price.

MSP Standard-Duty Precleaner



- **Material Path Option** – optimizes the blade coverage of the belt's material carrying path for better cleaning efficiency and less blade tension adjustment.
- **QMT Tensioner** – allows the blade to self-adjust to the belt as it wears. Consistent blade contact means continuous cleaning power.
- **Visual Tension Check** – a quick measurement of the tension spring makes it easy to see if the blade is at optimal tension.
- **ConShear™ Blade** – patented design that renews its cleaning edge as it wears and features a molded-in wear line that indicates when a blade change is needed.
- **Durable** – a larger pole diameter and corrosion-resistant steel construction means a long service life.
- **Works with Flexco Splices** – urethane blade glides over splices without damage or cleaning disruption.

Medium-Duty Precleaner

Extra cleaning power for tough jobs.

MMP Medium-Duty Precleaner



- **TuffShear™ Blade** – a sturdy 10-inch (250 mm) high blade that provides increased blade tip tension on the belt to peel off materials on high-speed and heavy-load conveyor applications.
- **Constant Blade-to-Belt Cleaning Force** – uses the “material path” option to match the blade width to the belt's material path and reduce the differential wear pattern on the blade.
- **Optimal Blade Tension** – visually check the blade tension quickly and easily. Simply measure the tension spring, and give the adjusting nuts a few turns to bring the blade back to optimal tension.
- **Easy to Install** – universal mounting plates and a three-piece pole make installation simple and quick. Step-by-step, illustrated instructions are included.
- **Compact** – requires only 4 inches (100 mm) of horizontal clearance for installation.

Replacement Blades

Longer life with less maintenance.

ConShear™ and TuffShear™ Blades



The same patented design for MSP and MMP Precleaners for superior cleaning and long-wear benefits.

- **Faceted Profile** – allows the blade to renew its cleaning edge as it wears.
- **Long Wearing** – a special abrasion-resistant urethane formula gives a long service life.
- **Molded-In Wear Line** – indicates when the blade is worn and needs to be replaced.
- **Optimal Cleaning Efficiency** – the blade width can be sized to fit the belt's material path for more even wear and less tensioning adjustment.
- **Quick Change** – no special tools are needed. Simply pull one pin and replace.
- **Available for Other OEM Cleaners** – ConShear and TuffShear blades are available for other cleaners. Call 1-800-541-8028 for more information.

Heavy-Duty Precleaner

Rugged and ready to work.

MHCP Heavy-Duty Cartridge Precleaner



- **SuperShear™ Blades** – 6-inch (150 mm) wide, segmented blades stand up to wet, sticky fire clay and abusive conditions and keep on cleaning.
- **Quick-Change Blade Cartridge** – remove the worn blade cartridge and replace it with a new one. Then replace the blades in the original cartridge for the next blade change-out.
- **Material Path Option** – blade segments can be adjusted to cover only the belt's material path, minimizing differential blade wear and retensioning maintenance.
- **Complete Cleaning System** – when teamed with the MHS HD Secondary Cleaner, it makes a system that delivers maximum cleaning power. If water is present, an MDWS DryWipe Cleaner can be added.

Precleaner Spring Tensioner (PST), Air/Water Tensioner (AWT) and Nitrogen Tensioner (NT)

- **Preloaded, Controlled Tension** – energizes the blades to deliver constant blade-to-belt contact and continuous cleaning power.



- **PST** – provides self-adjusting blade tension and can be easily reset to optimal blade tension with a few turns on the tension nuts.



- **AWT** – no retensioning maintenance is required. The correct blade tension is set once at installation and the pressure automatically adjusts as needed throughout the life of the blades.



- **NT** – similar to the AWT, but comes with a regulator for automatic tensioning with a nitrogen tank.

SuperShear™ Replacement Blade Cartridges

- **Designed for Abusive Conditions** – massive 12-inch (300 mm) high blades deliver a constant, effective cleaning force.
- **Force Distributor Vents** – molded into each blade to allow the blades to independently self-adjust to the belt as



Installation Accessories

Versatile, adjustable options to make installation easier.

Optional Mounting Kits

- **Mounting Bar Kit** – for mounting precleaners on open head pulleys. Simply weld on both sides of the head pulley and bolt on steel plate.
- **Mounting Plate Kit** – two 16" x 32" (400 x 800 mm) steel plates that fit right into place on the welded mounting bars for a sturdy span to mount precleaners.
- **Standard or Long Mounting Bracket Kit** – adjustable brackets for installing secondary cleaners. An optional top angle is also available.



Long Mounting Bracket Kit



Mounting Bar and Mounting Plate Kits

Pole extenders for extra-wide conveyor structures.

- **Standard Pole Length** – all Mineline® cleaner poles are belt width plus 48 inches (1200 mm) for the extra length needed for varying conveyor structures. The MMP is belt width plus 54 (1350 mm) and the MHCP is belt width plus 58 inches (1450 mm).

GOODYEAR
RUBBER PRODUCTS INC.

Call Toll Free: **1-866-711-4673**
WebSales@GoodyearRubberProducts.com

**We Ship
World Wide**

ROCKLINE®

Conveyor Products

Rockline®... Our name says it all. The respected Rockline conveyor product line is designed exclusively for the aggregate industry.

Featuring many of the same high-quality materials, designs and construction as our custom conveyor products, Rockline has been expertly engineered for easy, out-of-the-box installation, minimal maintenance, and budget-conscious pricing. Rockline products are durable and dependable; you can count on their quality and value day in and day out. With periodic parts replacement and occasional adjustments, Rockline products deliver years of outstanding service.

For more information or product specifications, call us at 1-800-541-8028.

Flexible Steel Lacing Company
2525 Wisconsin Avenue
Downers Grove, IL 60515-4200 U.S.A.
Phone: 800-541-8028
Web site: www.flexco.com



©2004 Flexible Steel Lacing Company, Printed in U.S.A.
U.S. Patent #D482,508S - ConShear™ Replacement Blades
U.S. Patent #6,823,983 - FormFlex™ Cushion
Rockline™ is a registered trademark, and ConShear™, FormFlex™ and
Positioner™ are trademarks of Flexible Steel Lacing Company.
For Reorder: Item Code X1312 Rev. 12/07

Distributed by:

Belt Trackers

Immediate, permanent solution for mistracking belts.

Belt Positioner™



- **Quick-Fix Belt Tracking** - correctly "positions" return side belts that consistently mistrack to one side of the conveyor.
- **Keeps On Working** - no pivoting mechanism to freeze up and stop working.
- **No Belt Edge Damage** - works on the return side belt's bottom cover and not on the belt's edges.
- **Easy to Set Up** - comes fully assembled and ready to install on the conveyor. Adjustment is simple. Results are immediate.



Skirt Clamps

Stops material spillage and eliminates safety hazards.

Skirt Clamps



NEW!

Anti-Vibration Clamp Pin – the wedge in the clamp pin has one side serrated, so when the wedge is pounded into the closed position the teeth lock it in place and guard against loosening due to vibration.

- **Stops Material Spillage** - contains materials in the conveyor loading zone.
- **No-Hassle Installation** - the parts interlock for easy assembly.
- **Quick Adjustment** - locking wedges on the clamp pins can be easily released by one person for skirt rubber adjustment.

LS Skirt Clamps

- **"Limited Space" (LS) Option** - the overall clamp height is reduced to 5" for restricted space conveyors.



PAL PAK Option

The "Pick-A-Length" (PAL) option is for long or special length requirements. The PAL PAK contains two clamp



ROCKLINE®

Conveyor Products



GOODYEAR
RUBBER PRODUCTS INC.

Call Toll Free: 1-866-711-4673
WebSales@GoodyearRubberProducts.com

**We Ship
World Wide**

Belt Cleaners

Effective belt cleaning at an affordable price.

EZP1 Precleaner



- **Easy Set Tensioner (EST)** - a spring tensioner that is self-contained right on the cleaner mounting plate and pole.
- **Easy to Install** - pole location and correct tensioning are critical to cleaning efficiency.
- **Material Path Option** - for better cleaning efficiency and less blade adjustment.
- **ConShear™ Blade** - patented design that renews its cleaning edge as it wears.
- **Visual Tension Check** - quick inspection to determine if blade is at optimal tension.
- **Quick-Change Blade** - for fast and easy blade replacement.

EZS2 Secondary Cleaner



- **Patented FormFlex™ Cushion** - segmented cushions allow each blade to self-adjust to the belt independently for continuous cleaning power.
- **Impact-Resistant Carbide Blades** - for long wear, optimal cleaning and compatibility with mechanical splices.
- **Compact Design** - requires only 8-1/2" of vertical and 4" of horizontal clearance for correct installation.
- **Easy to Install.**
- **Low Maintenance.**



ConShear™

Cleans longer with less maintenance.

Replacement Blades



- **Optimal Cleaning Results** - the blade width should be sized to fit the belt's material path.
- **Faceted Profile** - patented design allows the blade to renew its cleaning edge as it wears.
- **Molded-in Wear Line** - indicates when the blade is worn and needs to be replaced.
- **Quick Change** - no special tools are needed. Simply pull one pin and replace.

ConShear™ Replacement Blades for Other OEM Cleaners

ConShear™ blades can be ordered for many other brands of solid blade cleaners to offer the superior cleaning and long wear benefits. Call Customer Service at 1-800-541-8028 for

Belt Plows

Critical belt cleaning at the tail pulley.

Diagonal Plow



- **Protects Conveyor Components** - removes lumps, rocks and other fugitive materials before they damage the belt, mechanical splice, lagging, or tail pulley.
- **Exclusive Blade Design** - a 20° angle on the blade's leading edge "spirals" material quickly off the belt.
- **Installs in Minutes** - the unit is easy to assemble and comes with universal mounting brackets to fit any conveyor structure.
- **Economical** - durability and low cost make the plow very versatile. Replacement blades are also low cost and easy to change out.



GOODYEAR
RUBBER PRODUCTS INC.

Call Toll Free: 1-866-711-4673
WebSales@GoodyearRubberProducts.com

**We Ship
World Wide**

Flex-Lok™ Conveyor Skirt Clamps

- Installs quickly and easily
- Helps eliminate loading point spillage

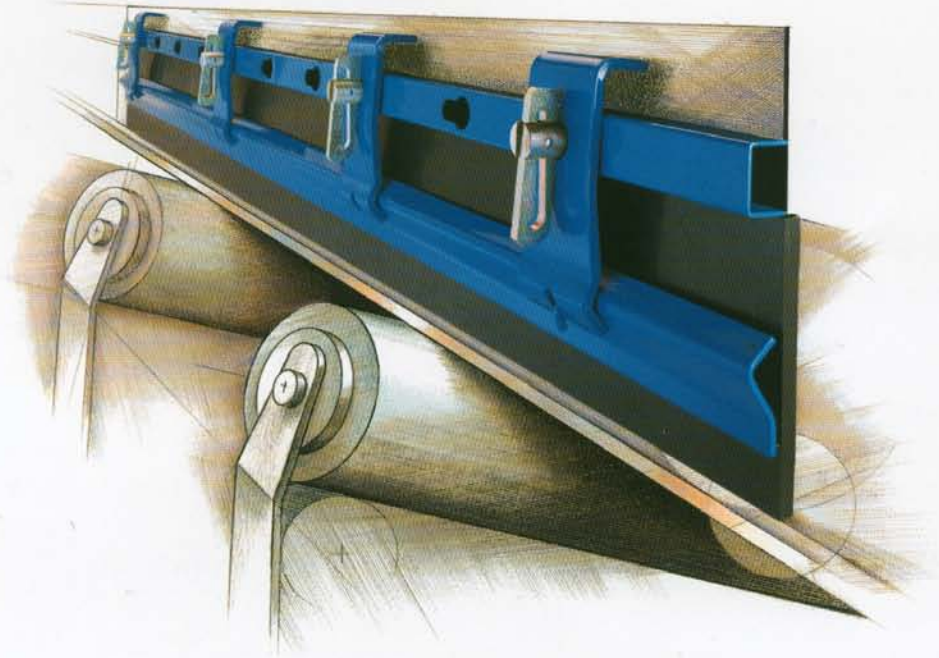

Easy Installation

Each Flex-Lok™ unit is tack-welded to the skirt board. Assembly requires only a non-metal hammer to lock the skirt rubber into position.

Quick Adjustment

One person can reposition worn skirt rubber in minutes. Simply unlock the self-contained clamp pins, move the rubber and relock.



Safe Service Access

All skirt clamp maintenance is done from the side of the conveyor. There are no nuts and bolts to work on inside the conveyor chute.

New Mini Flex-Lok For Confined-Space Applications

With an overall height of just 5½" (135 mm), our new Mini Flex-Lok installs quickly in tight chute configurations and on portable equipment with restricted space.



The Flex-Lok™ Skirt Clamp

is designed with versatility to meet the needs of any conveyor loading site—even severe, heavy loading applications.

Flex-Lok can be installed on perpendicular and vertical skirt boards. The exclusive design features a unique clamp pin with a captive wedge that can be locked in any position 360° around the pin. The remaining parts interlock, so even when the clamp pins are unlocked, one person can effectively adjust or replace the skirt rubber.

Properly installed, Flex-Lok insures the skirt rubber will not rub on the belt causing premature wear or gouging marks. Installation is easy with Flex-Lok's simple instructions.

Flex-Lok comes in standard six foot (1.8m) lengths and can be easily modified for shorter length requirements. The clamp plates and clamp pins can be placed in various positions along the clamp runner, even in the most restrictive environments. Extra plates and pins can be added for additional skirt rubber support at extremely heavy loading sites.

The captive wedge in the clamp pin insures that no parts get lost.

Clamp plate secures skirt rubber in proper position to insure no damage is caused to the belt.

Restraining bar is held in place by clamp plates so hands are free to adjust skirt rubber.

New expanded belt thickness range: standard, $\frac{3}{16}$ " (8 mm) to 1" (25 mm); mini, $\frac{3}{16}$ " (8 mm) to $\frac{5}{16}$ " (16 mm).

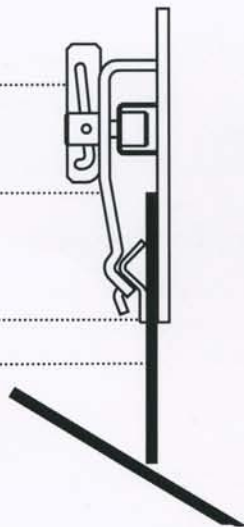

The Flex-Lok Skirt Clamp is part of Flexco's expanding line of Belt Conveyor Products (BCPs). These products team up with our world-leading Mechanical Belt Fasteners to provide belt conveyor maintenance solutions.

Ordering Information

Description	Ordering Number	Item Code
Flex-Lok Skirt Clamp	FLSC-I	71052
Mini Flex-Lok	FLSCM-1	71055
Replacement Parts		
Clamp Pin	FL-CP-M	71056
Mini Clamp Pin	FL-CP-I	71141
Clamp Plate	FL-PC-I	71057
Mini Clamp Plate	FLM-PC	71140
Restraining Bar	FL-RBI	71060
Clamp Runner	FL-RPI	71058

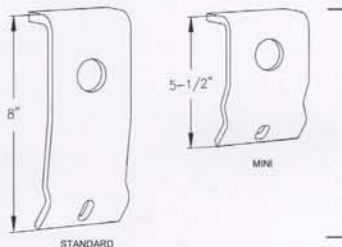

Two models are available to fit your conveyor requirements.



Flexible Steel Lacing Company
 2525 Wisconsin Avenue
 Downers Grove, IL 60515-4200 U.S.A.
 Telephone: (630) 971-0150
 Fax: (630) 971-1180
 E-mail: advertising@flexco.com
 Visit our Web site at: www.flexco.com

Australia: 61-2-9680-3322 • England: 44-1274-600-942 • Germany: 49-7428-9406-0
 Mexico: 52-55-5674-5326 • Republic of South Africa: 27-11-608-4180

©1999 Flexible Steel Lacing Company. 10/99-25
 Flex-Lok™ is a trademark of Flexible Steel Lacing Company.



GOODYEAR
 RUBBER PRODUCTS INC.

Call Toll Free: **1-866-711-4673**
WebSales@GoodyearRubberProducts.com

**We Ship
 World Wide**



Far-Pul® HD® Belt Clamps



Aluminum Content

Aluminum Alloy Type	Percent	
	Mg Magnesium	Ti Titanium
6061	1.00%	0%

Far-Pul® HD® Belt Clamps are the light-weight belt maintenance tool specially engineered for heavy-duty applications.

Unique design, easily adjustable

The unique design of the Far-Pul HD provides even tensioning across the entire belt width for a secure grip. And with a load capacity of up to three tons (2.7 metric tons), when used with two 1-1/2-ton chain come-alongs, it is ideal for rubber covered and PVC heavy-duty belting from 7/32" (6 mm) to 1" (25 mm) thick.

The Far-Pul HD also accommodates a variety of belt widths. So the need to inventory different clamp bars for different belt widths is eliminated. Clamping scissors slide easily into place against both belt edges for easy adjustability. And clamp-bar pins simplify alignment and positioning.

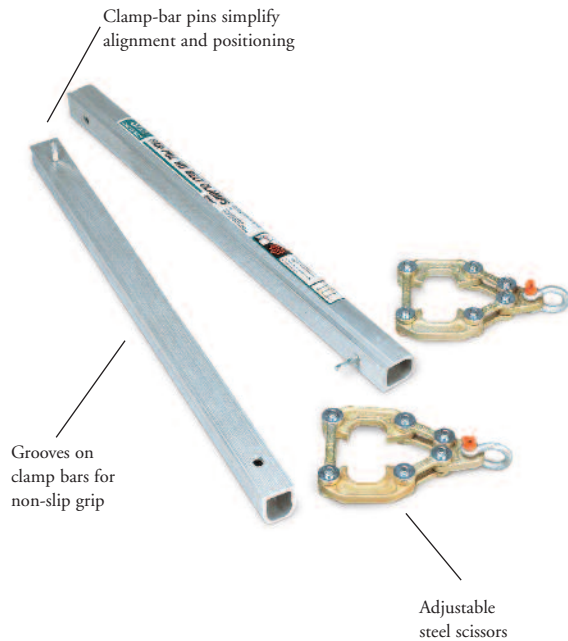

Far-Pul® HD®



Far-Pul® HD® Belt Clamps

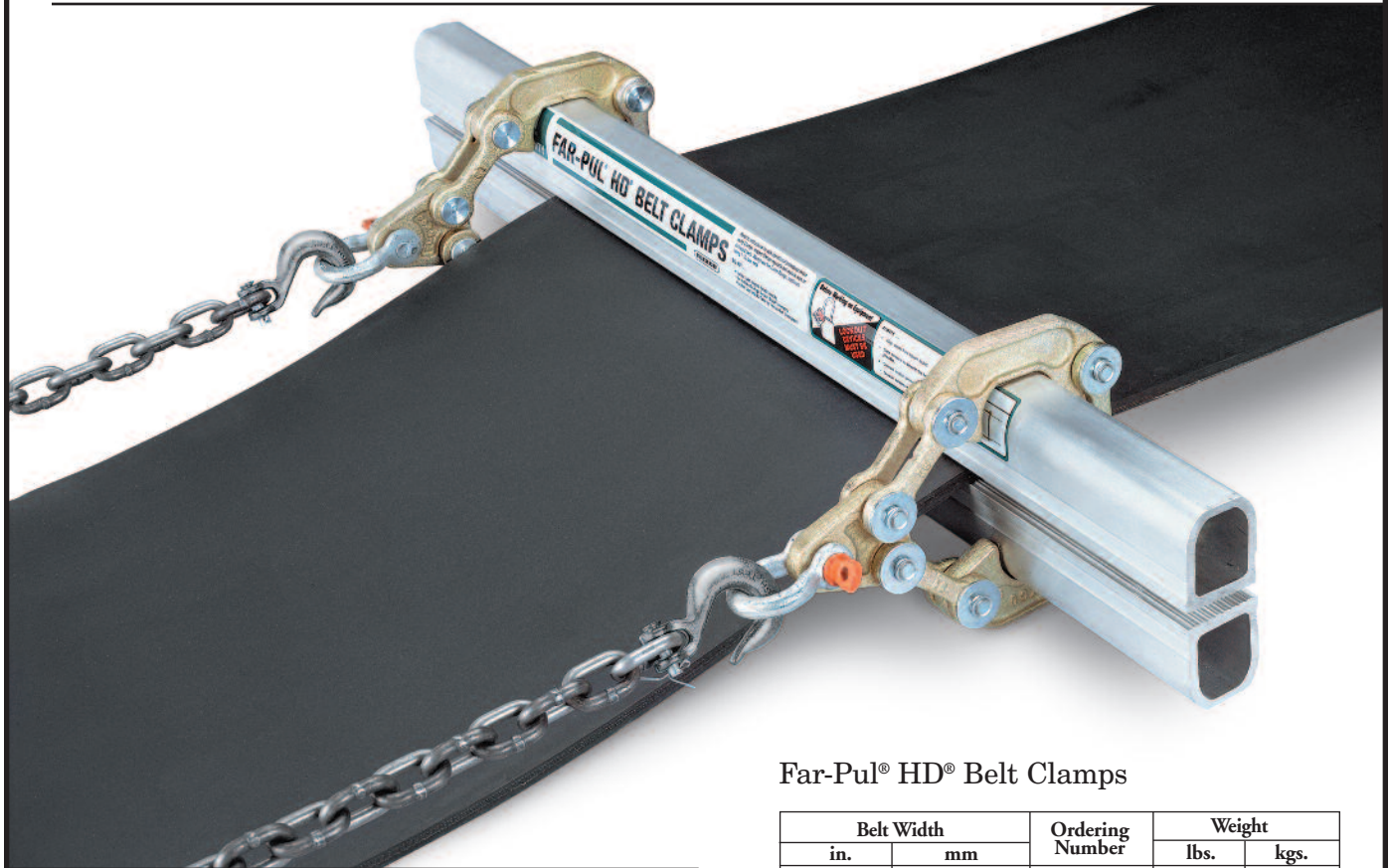

Far-Pul® HD® Belt Clamps

Belt Width		Ordering Number	Weight	
in.	mm		lbs.	kgs.
Up to 30	Up to 750	LSHD30	79.0	35.8
Up to 36	Up to 900	LSHD36	87.0	39.5
Up to 42	Up to 1050	LSHD42	91.0	41.3
Up to 48	Up to 1200	LSHD48	98.0	44.5
Up to 54	Up to 1350	LSHD54	103.0	46.7
Up to 60	Up to 1500	LSHD60	110.0	49.9
Up to 72	Up to 1800	LSHD72	121.0	54.9

Note: A complete set of Far-Pul® HD® Belt Clamps includes four clamp bars, and four steel clamp scissors with carry bag. Come-alongs not included.

Far-Pul® HD® clamp bars are constructed from heat-treated extruded aluminum so they resist corrosion and won't seize up in wet and corrosive environments. Clamps include adjustable steel scissors.

Engineered for heavy-duty applications

- Aggregate
- Steel
- Coal
- Potash
- Grain
- Foundry
- Salt

Aluminum Content

Aluminum Alloy Type	Percent	
	Mg Magnesium	Ti Titanium
6061	1.00%	0%



2525 Wisconsin Avenue
Downers Grove, IL 60515-4200 U.S.A.
Telephone: (630) 971-0150
Fax: (630) 971-1180
E-mail: info@flexco.com
Visit our Web site at: www.flexco.com



www.flexco.com

Australia: 61-2-9680-3322 • England: 44-1274-600-942 • Germany: 49-7428-9406-0 • Mexico: 52-55-5674-5326 • South Africa: 27-11-608-4180

© 2007 Flexible Steel Lacing Company. Far-Pul® and HD® are registered trademarks of Flexible Steel Lacing Company. Part#X0724

GOODYEAR
RUBBER PRODUCTS INC.

Call Toll Free: 1-866-711-4673
WebSales@GoodyearRubberProducts.com

**We Ship
World Wide**

SmartClamp™

As part of the FlexcoSafe™ belt conveyor maintenance solutions, the SmartClamp™ system provides both safety and efficiency when clamping belts for the installation of Clipper® and Alligator® mechanical belt fasteners.

A complete system to
Work Safer.
 Work Smarter.

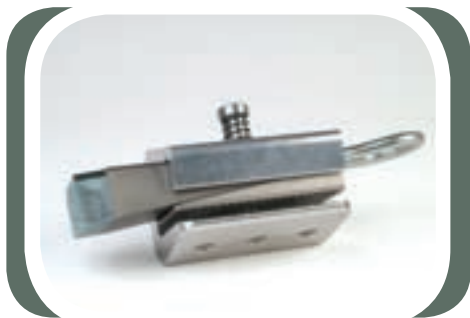

Faster. Easier.

Unlike other clamp systems which require time consuming adjustments, the SmartClamp™ only needs a quick tap of a hammer to prelock the wedges. Attach and tighten come-alongs and the final lock is engaged. This fast set up saves precious and costly time during a breakdown situation.

The belt clamps can also be conveniently used to 'string' new belts onto the conveyor structure. The belt is clamped in same manner and the pull loop doubles as a handle to quickly and easily string the belt.

Safer. Stronger.

The SmartClamp was thoughtfully engineered to maximize strength and performance. The wedge grip design places an evenly distributed pressure load over the entire clamp interface. The set of four clamps permits for safe pulling of belts with up to 2,000 pound of load.

Smarter.

With SmartClamps you do not need to sacrifice efficiencies for safety. These easy-to-install belt clamps make the choice obvious for maximum belt conveyor uptime.

SmartClamp™ Features



Large impact plate for easy striking surface.



Return Spring Post holds wedges up so belt can be easily slid into clamping position.

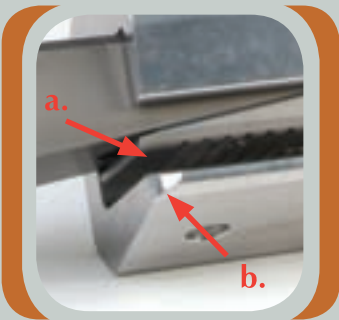

Textured lower wedge provides additional holding strength (a).

Beveled edges of the housing permit for easy belt engagement. Elimination of sharp corners and edges provide a smoother transition from clamp to belt, reducing the chance of belt damage (b).



Flexible Steel Lacing Company
2525 Wisconsin Avenue
Downers Grove, IL 60515-4200 U.S.A.
Telephone: (630)-971-0150
Fax: (630)-971-1180
E-mail: info@flexco.com



Ordering Information

Order Number	Item Code	Weight
SMARTCLAMP Complete Set of 4	04073	45lb. for complete set

Other Flexco Safe™ Products:

Clipper® 845 Belt Cutter

Designed to enhance operator safety with the fully enclosed cutting blade, this light-weight, portable belt cutter delivers straight cuts, time after time. Available in 4 widths: 36", 48", 60" and 72" (900, 1200, 1500, 1800 mm).

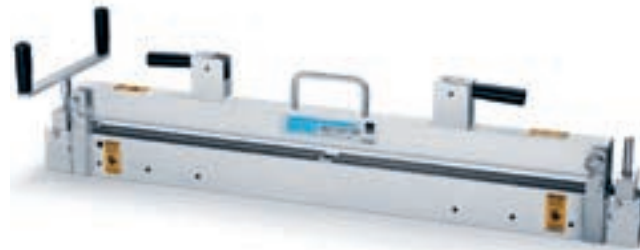

www.flexco.com

FLEX-LIFTER™

Conveyor Belt Lifter

FLEXCO®

BELT MAINTENANCE TOOLS

A Tough, Versatile Beltline Tool

Lifting a tensioned conveyor belt out of the way to do maintenance work is a difficult job. It can be time-consuming and dangerous. The Flexco® Flex-Lifter™ makes the job safe and easy. It takes on the toughest jobs, like lifting a belt even when it is loaded. The Flex-Lifter has the highest safe lift rating available at 4000 lb (1810 kg). And this tool is versatile. Adjustable wings make it easy to lift all troughed or flat topside belts. Also, a Return Lift Bar is included with each lifter to quickly adapt it for use on return side belts.

Safety is a Key Feature

- A wide, dual-rail base maintains unit stability even if the belt backs up a little.
- Each unit is rated for safe lift capacity of 4000 lb (1810 kg).
- Can safely lift a fully loaded belt.
- Optimized lift height gives room to work safely.
- All standard safety rules for working on conveyors must be observed.



A High Lift for Varying Tasks

- The Medium model gives a vertical lift of 14" (350 mm) and the Large model a lift of 16" (400 mm).
- Provides room to safely and easily change out worn idler rollers.
- Can lift and flatten belt to make an ideal splicing station. (NOTE: Belt tension must be released before using Flexco® Belt Clamps.)
- A closed unit height of 6-3/4" (169 mm) allows the tool to be easily placed on the conveyor between the belts.
- The extension legs can be used in two positions to sit higher or lower on the conveyor structure.

Works on Top or Return Side Belts

- Trough wings will handle topside belt trough of any degree.
- Trough wings are adjustable to handle flat belts.
- A Return Lift Bar easily attaches to the unit for lifting return side belts.

Conveyor Belt Lifter

Other Key Features and Benefits:

- **Easy to Use.** The tool can be operated with a drill motor, ratchet or impact wrench along with the appropriate sized socket.
- **Works on a Range of Conveyors.** The Medium model is for belt widths 36"-60" (900-1500 mm), and the Large model is for belt widths 48"-72" (1200-1800 mm). Adjustable length extension legs slide out to fit the conveyor structure.
- **Compact.** Fits easily into confined areas.
- **Transportable.** The tool can be carried to the job site and easily placed into position on the conveyor structure. The Medium model weighs only 60 lb (27 kg) and the Large model weighs 74 lb (33 kg). Each unit has a carrying handle.
- **Won't damage the belt.** Lifts the belt from underneath. Does not clamp onto the belt's edges or cover.
- **Corrosion Resistant.** The components are all made from anodized aluminum for protection and long life.

The Flex-Lifter makes beltline maintenance tasks easier, faster and safer.



Flexible Steel Lacing Company
2525 Wisconsin Avenue
Downers Grove, IL 60515-4200 U.S.A.
Telephone: (630)-971-0150
Fax: (630)-971-1180
BCP Help Line: 1-800-253-8132
E-mail: info@flexco.com



Application Uses:

1. For lifting troughed belts. The trough wings are placed in the "up" position for lifting troughed belts. The wings will work with all troughed belts.
2. For lifting flat belts. Place the trough wings in the "down" position to lift flat belts.
3. For lifting return belts. Lower the trough wings to the "down" position. Place the Return Lift Bar under the return side belt and secure the chains on both sides to the trough wings using the wing pins.



Lifting troughed belts

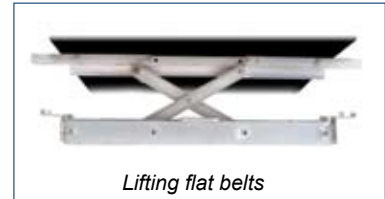

Lifting flat belts



Lifting return belts



Technical Information:

- Rated for a safe lift of up to 4000 lb (1810 kg).
- Will lift a fully loaded, tensioned belt.
- Must not be used within 20' (6.2 M) of the head or tail pulley.
- Can be operated with a ratchet, drill motor, or impact wrench (not included).
- Medium requires a 3/4" (19 mm) socket. Large requires a 15/16" (24 mm) socket. (Sockets not included).

Specifications

Range, Weight and Height				
Sizes	Belt Width Range	Weight	Closed Height	Vertical Lift
Medium	36"-60" (900-1500 mm)	60 lbs. (27 kg)	6.75" (169 mm)	14" (350 mm)
Large	48"-72" (1200-1800 mm)	74 lbs. (33 kg)	6.75" (169 mm)	16" (400 mm)
Return Lift Bar (Medium)		21 lbs. (10 kg)		
Return Lift Bar (Large)		40 lbs. (18 kg)		

Ordering Information

Flex-Lifters		
Description	Item Code	Ordering Number
Medium Flex-Lifter	76469	FL-M
Large Flex-Lifter	76470	FL-L

www.flexco.com

Australia: 61-2-9680-3322 • England: 44-1274-600-942 • Germany: 49-7428-9406-0 • Mexico: 52 5556-74-53-26 • Republic of South Africa: 27-11-974-2771



Call Toll Free: **1-866-711-4673**
WebSales@GoodyearRubberProducts.com

**We Ship
World Wide**



DRX™
Impact Beds

Tough Design. Soft Results.

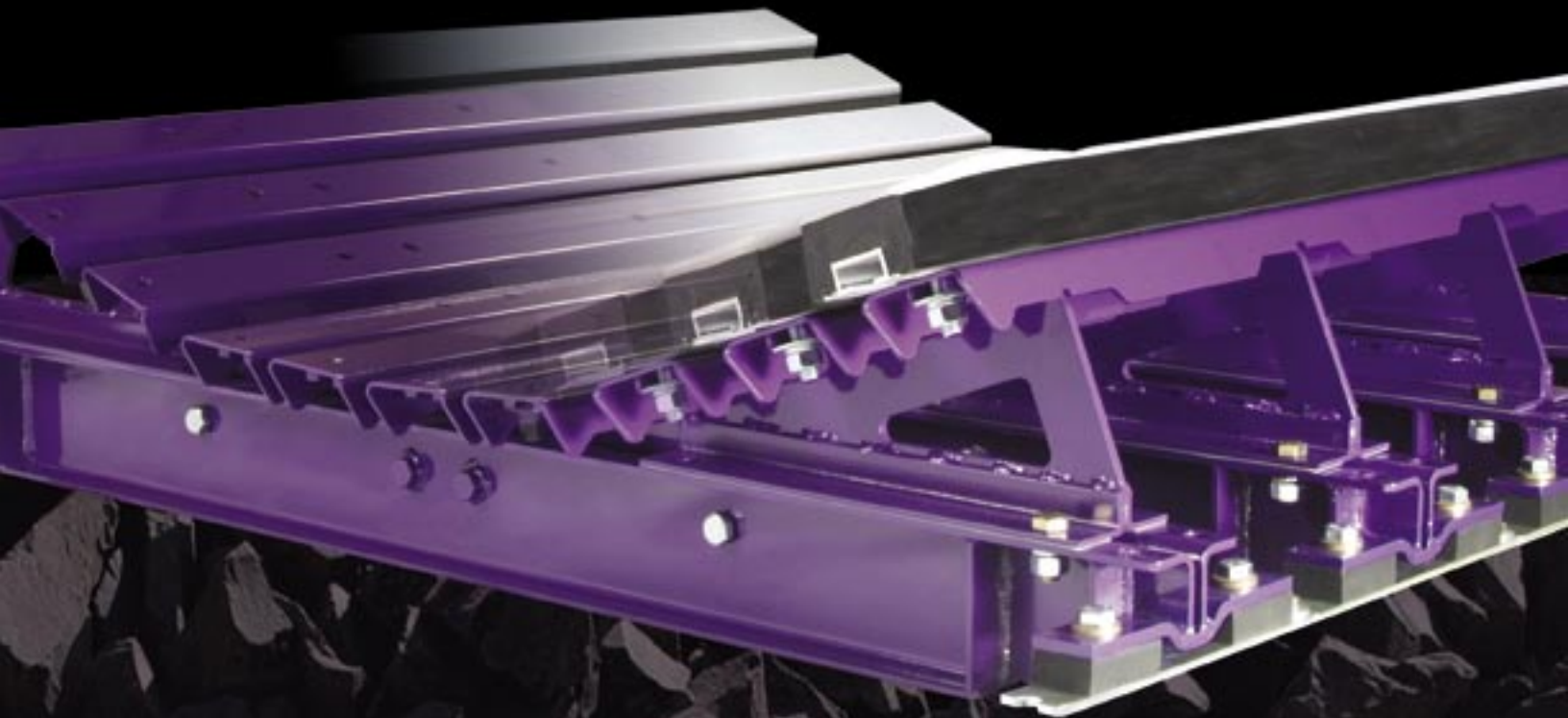

It's the Structure, Not the Bars

Performance is engineered into the entire DRX Impact Bed structure—from extreme construction to innovative bar supports to multi-level belt protection. Our enhanced design controls acceleration to deaden impact energy, reduce damaging vibrations and extend belt life.



Call Toll Free: 1-866-711-4673
WebSales@GoodyearRubberProducts.com

**We Ship
World Wide**

FLEXCO

DRX™

Impact Beds

Tough Design. Soft Results.

DRX—Designed for Xtra Impact Relief and Maximum Belt Protection.

Flexco's DRX (Dual Relief Xtra™) Impact Beds are designed with one simple goal: protect the belt. How we meet that goal is revolutionary. We've engineered superior belt protection into the entire structure—not just the bars. Sturdy components, robust construction and convenient maintenance make our line more durable and efficient than others. Then, our exclusive Velocity Reduction Technology™ controls acceleration to deaden impact energy and reduce reaction forces, providing unmatched belt protection.

Go Beyond the Bars

Velocity Reduction Technology™ Works Like Nothing Else.

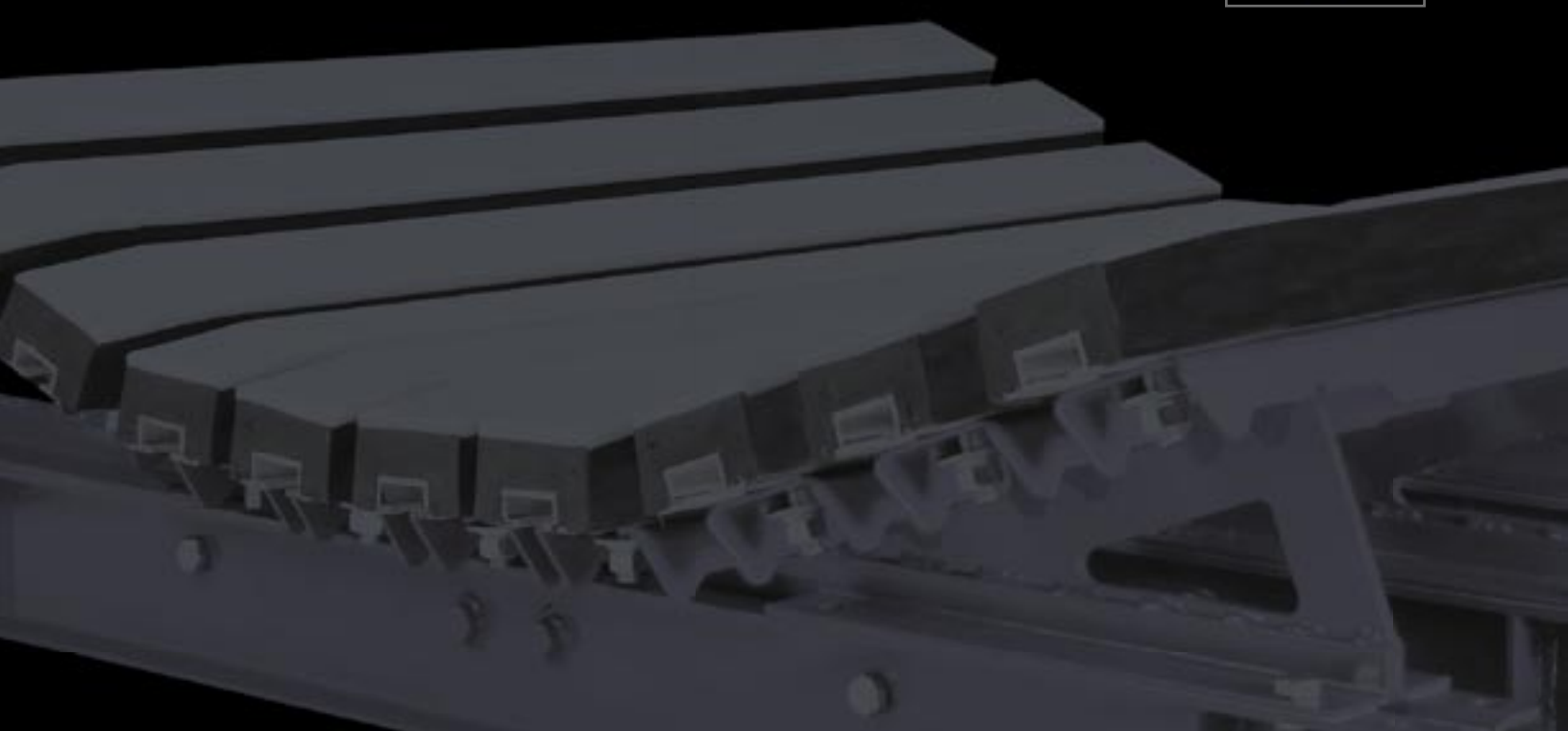
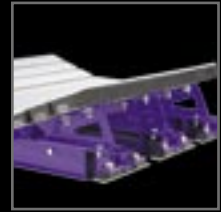
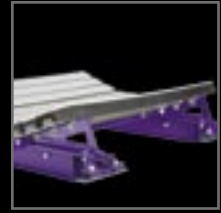

GOODYEAR
RUBBER PRODUCTS INC.

Call Toll Free: **1-866-711-4673**

WebSales@GoodyearRubberProducts.com

**We Ship
World Wide**

DRX—Engineered to Perform Better From Top to Bottom.

Flexco's **DRX Impact Beds** set a new standard in performance. DRX beds have been carefully engineered to provide convenient service and protect your belt and conveyor better than any other beds.

- **Slide-Out Service™** makes maintenance convenient and safe. DRX Impact Beds separate in the middle and the two sides slide apart. This provides direct access to all the bars and bolts for easy, quick and safe maintenance. A complete bar change out takes just one or two hours.
- **Velocity Reduction Technology™** is found only in the DRX line! Two levels of *reaction force reduction* absorb impact energy and minimize transmission back to the belt. Velocity Reduction Technology™ delivers longer belt life, less stress on the conveyor structure and reduced material degradation.
- **Impact Bar Supports** enhance bar function. Made from high-strength steel, our inverted-design Impact Bar Supports allow the impact bars to expand and function properly to absorb more impact energy.
- **Channel Crossbeams** efficiently transfer damaging impact energy to the isolation mounts. Contoured ends on the Channel Crossbeams save vertical space and leave a more robust middle section to carry the load.
- **Engineered Better**—down to the details. All components are designed to make your job easier and more productive.

We Thought of All the Xtras!

For light-duty applications—up to 200 lb-ft



DRX200

DRX200



DRX750



DRX1500

Only DRX Beds Meet or Exceed CEMA Standards

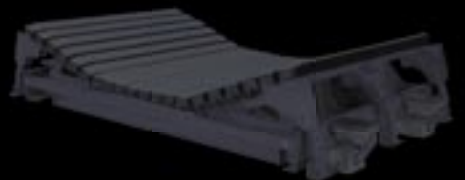
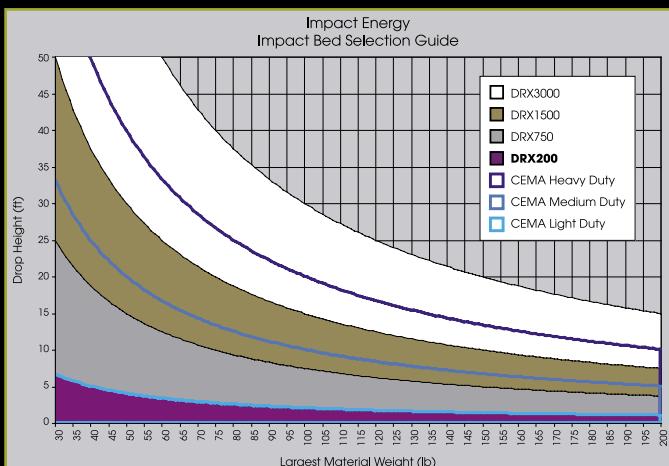

DRX3000

DRX200 Impact Beds.

Designed for the unique needs of the sand and gravel market, light-duty DRX200 Impact Beds are a smarter alternative to impact idlers or hybrid systems. The DRX200 offers convenient Slide-Out Service™ that allows direct access to all the bars. This makes maintenance—and installation—quick and convenient. Plus, our expert engineers evaluated all components and maximized the effectiveness of even the smallest details.

DRX200

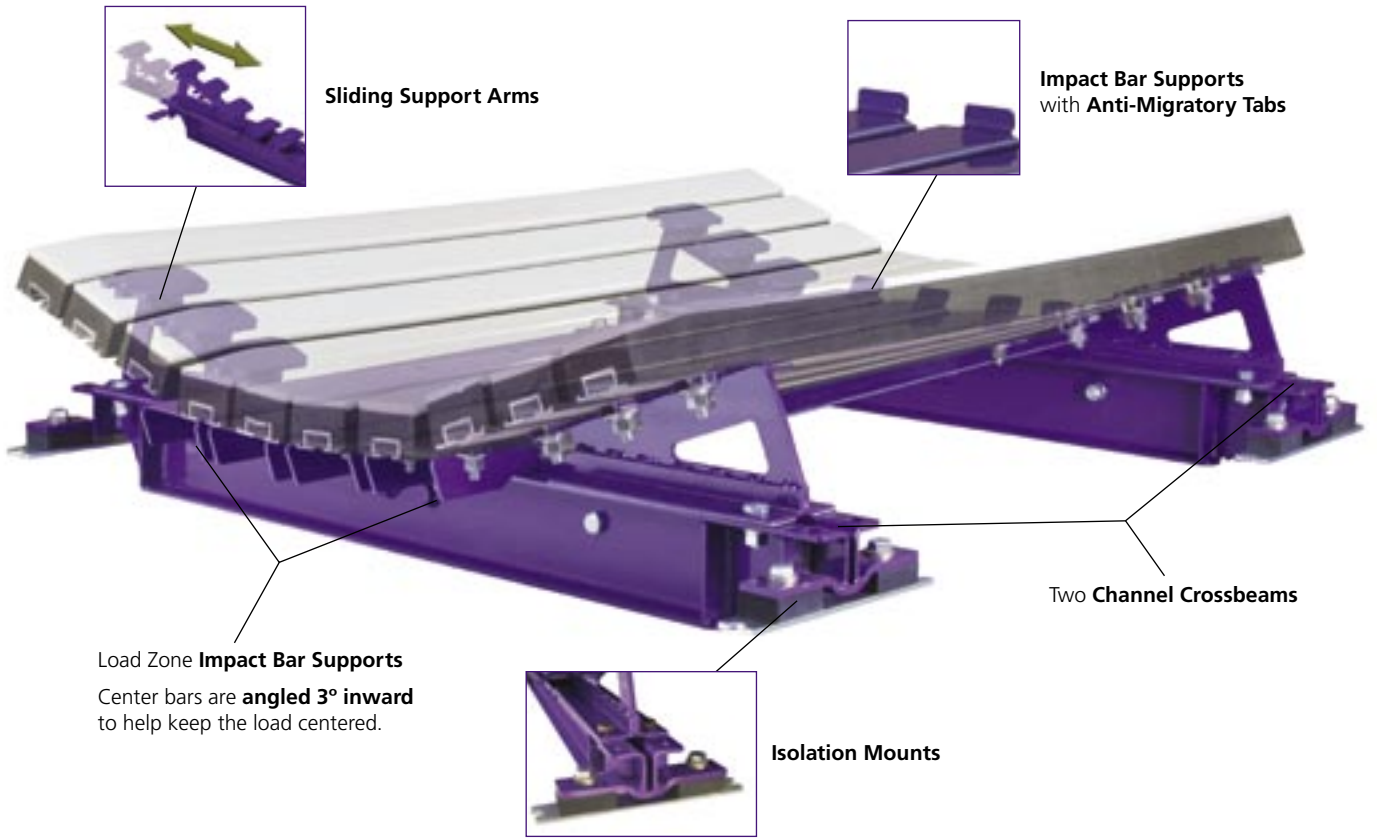

Xtra Safety and Convenience.

Slide-Out Service™ means converting from run position to maintenance position—or back again—takes just minutes.

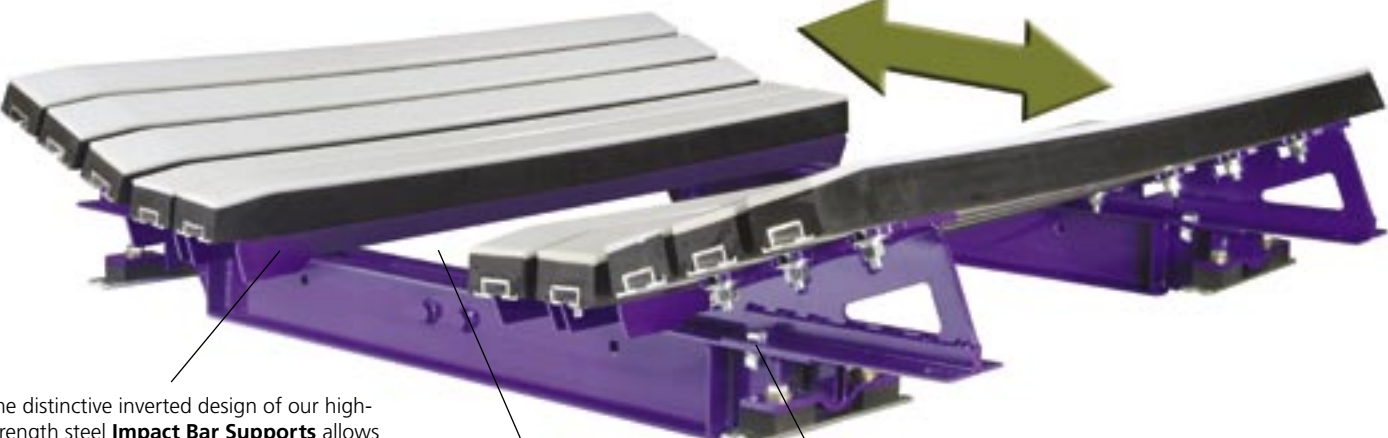

The distinctive inverted design of our high-strength steel **Impact Bar Supports** allows the impact bars to function properly, and expand and absorb impact force. This design also maintains optimal clearance between the supports so fugitive material can fall through and not build up between bars.

The DRX200 separates in the middle and slides out for efficient maintenance and direct access to all the bars and bolts—even the center bars are easy to access.

When the two sides are moved out, a pair of **Positive Anchoring Bolts** ensures that each side remains secured for safety. When returned to the run position, the side assemblies easily engage with a central locating pin, while the bolts secure each side back in place.



DRX200: A Smart Choice.

DRX200—Designed for Your Unique Situation.

Engineered specifically with sand and gravel operations in mind, the DRX200 Impact Bed is intended for up to 200 lb-ft applications of impact energy. (See calculation chart below.) Generally recommended for -4" to -6" (-100mm to -150mm) material, or situations where the greatest dimension of the rock is less than six inches, the DRX200 works with 24" – 72" (600mm – 1800mm) belts.

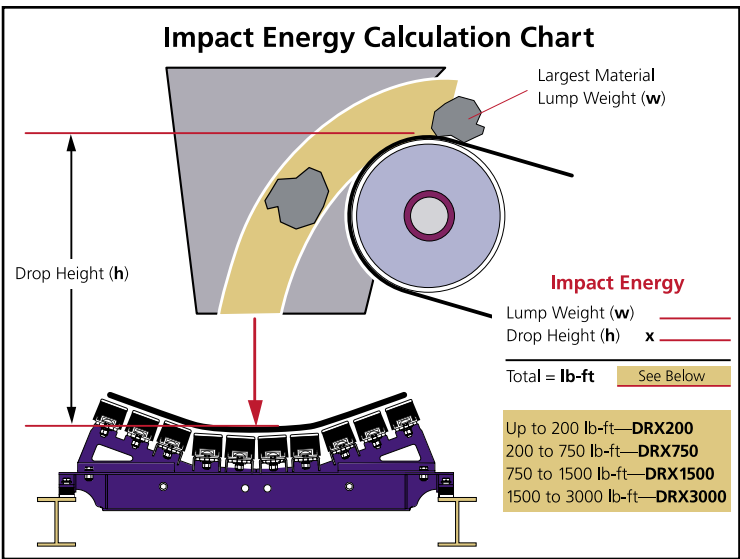

Slide-Out Service™ on the DRX200 Makes Maintenance Hassle Free.

The DRX200 Impact Bed separates in the middle, allowing the two sides to slide apart and out. This unique Slide-Out Service™ feature gives direct access to all the bars and bolts for quick, easy and safe maintenance. The beds offer rapid conversion from run position to service position and back again. Other beds require that a two-man crew spend up to eight hours replacing the bars. With a DRX bed, that same crew can *finish a complete bar change out in just one to two hours*. Further, the DRX line is designed to work with any common rubber impact bar. Use existing stock and maintain a smaller inventory for future change outs.

Safety is also improved with a DRX bed. When the two sides are moved out, a pair of Positive Anchoring Bolts ensures that each side remains secured for safety. When returned to the run position, the side assemblies easily engage with a central locating pin, while the bolts secure each side back in place.



Velocity Reduction Technology™ Extends Belt Life.

The DRX line features our exclusive Velocity Reduction Technology™. Our distinctive inverted-design Impact Bar Supports allow the impact bars to expand and function properly as a first level of defense against damaging reaction forces. Then Isolation Mounts provide a second level of reaction force reduction, absorbing additional impact energy and minimizing transmission back to the belt. Velocity Reduction Technology™ delivers:

- Less belt wear and reduced belt damage for longer belt life
- Less stress on bed and conveyor structures
- Less rebounding and material degradation

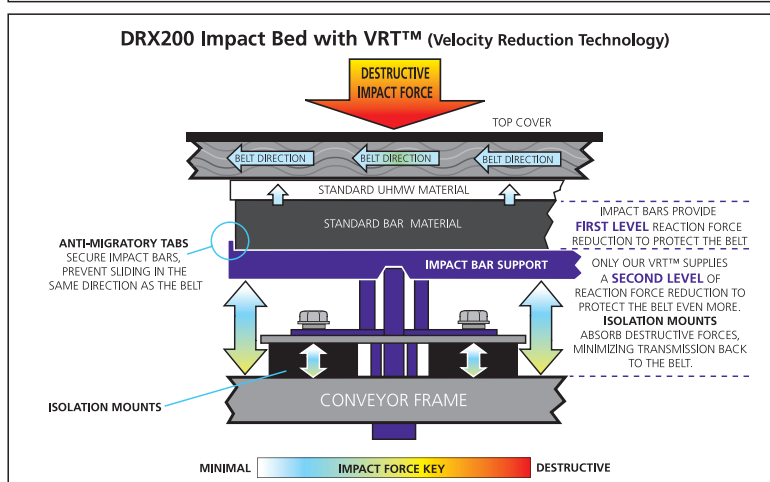
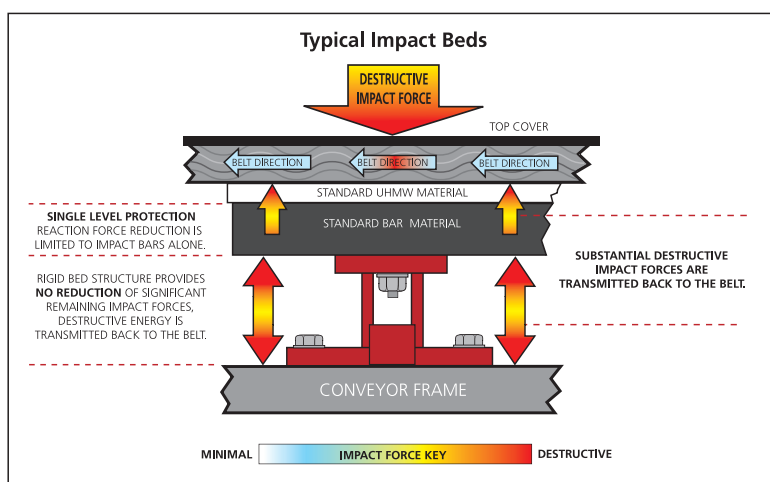



Superior Impact Bar Supports Enhance Bar Function.

Made from high-strength steel, our inverted-design Impact Bar Supports let the impact bars expand to absorb more damaging impact energy. This design also maintains optimal clearance between the supports so fugitive material can fall through and not build up. Plus, an Anti-Migratory Tab on each support bar secures the impact bar and prevents it from sliding in the same direction as the belt. This allows us to keep a stocked inventory and reduces turnaround time.

Channel Crossbeams Efficiently Transfer Impact Energy.

Our Channel Crossbeams feature gussets to tie the top and bottom flange together to improve the capacity and overall efficiency of the beams. This means we have lighter and stronger beams for your applications. Contoured ends on the Channel Crossbeams save vertical space and leave a thicker, more robust middle section to carry the load. All standard DRX Impact Beds use the same Channel Crossbeams.

Engineered Better—Down to the Details.

It's true—the devil is in the details. That's why even our smallest parts are designed to make your job easier and more productive.

- DRX Impact Beds use our exclusive, anti-spin Square Washers to attach the impact bars to the Impact Bar Supports. These innovative washers work with standard, inexpensive carriage bolts. If ever needed, carriage bolts can be torched off and replaced for pennies. Other beds require expensive T bolts.
- DRX beds are powder coated for better corrosion resistance, more durable finish and a more attractive appearance.
- On all DRX beds the four center Impact Support Bars tilt 3° inward. It's a subtle detail that helps center the load on the belt.

Fast, On-time Shipping.

We can ship your DRX200 Impact Bed in just two weeks from our stocked inventory. Other beds routinely take three to five weeks to ship a bed, extending downtime and reducing your productivity.

Contact Us Today.

As a partner in your productivity, Flexco can help you determine the best impact bed to meet your individual need. With the DRX200 Impact Bed there are no data sheets to fill out. Just call your Flexco Field Engineer and give the lump size, drop height and roller size with the corresponding CEMA rating, and he will recommend the ideal bed for your specific application.



Xtra Safe, Convenient Installation.

Flexco's DRX Impact Beds were engineered for safety and convenience from the very beginning. Our rugged system breaks down into individual components that can be easily hand carried to the installation site. One or two people can lift each component into place. Only simple tools are required and the entire process takes a matter of hours.



STEP 1

Use template to measure and cut holes.



STEP 2

Parts can be moved into place by one to two people.



STEP 3

Set Channel Crossbeams into position on the structure.



STEP 4

Measure out proper Channel Crossbeam distance and put into place.



STEP 5

Bolt down the Channel Crossbeams.



STEP 6

Remove Support Arm mounting bolts and slide Support Arm to service position and rebolt.



STEP 7

Set bars in place over Support Arms.



STEP 8

Bolt bars to Support Arms.



STEP 9

Slide Support Arms from service position to run position.



STEP 10

Bolt Support Arms to Channel Crossbeams.



STEP 11

Clean up work area and remove tools.

DRX—Engineered to Perform Better From Top to Bottom.

Flexco's DRX Impact Beds set a new standard in performance. DRX beds have been carefully engineered to protect your belt and conveyor better than any other beds.

- **Velocity Reduction Technology™** is found only in the DRX line! Two levels of *reaction force reduction* absorb impact energy and minimize transmission back to the belt. Velocity Reduction Technology™ delivers longer belt life, less stress on the conveyor structure and reduced material degradation.
- **Slide-Out Service™** makes maintenance convenient and safe. DRX Impact Beds separate in the middle and the two sides slide apart. This provides direct access to all the bars and bolts for easy, quick and safe maintenance. A complete bar change out takes just one or two hours.
- **Impact Bar Supports** enhance bar function. Made from high-strength steel, our inverted-design Impact Bar Supports allow the impact bars to expand and function properly to absorb more impact energy.
- **Channel Crossbeams** efficiently transfer damaging impact energy. Contoured ends on the Channel Crossbeams save vertical space and leave a more robust middle section to carry the load.
- **Engineered Better**—down to the details. All components are designed to make your job easier and more productive.

We Thought of All the Xtras!



DRX200

For medium-duty applications—
200 – 750 lb-ft

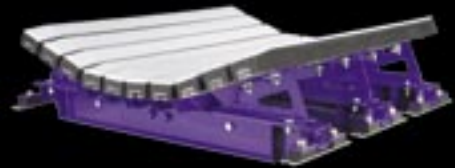

DRX750

DRX750



DRX1500

Only DRX Beds Meet or Exceed CEMA Standards

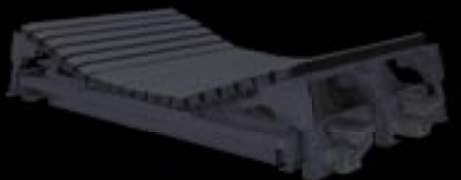
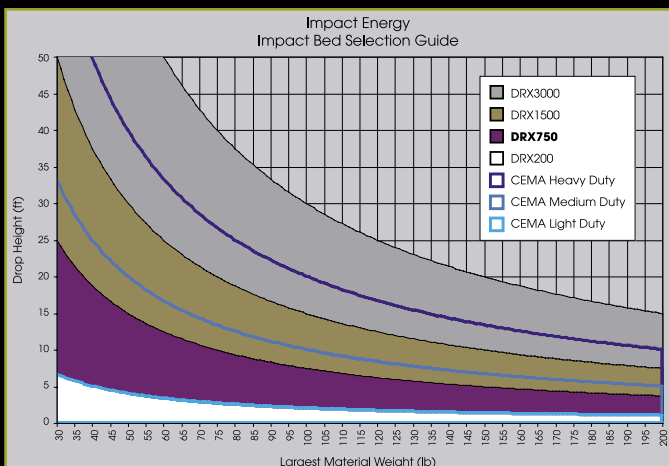

DRX3000

DRX750 Impact Beds.

The DRX750 Impact Bed is a medium-duty bed designed to meet the needs of the hard rock and limestone markets. The DRX750 features Velocity Reduction Technology™ with two levels of effective reaction force reduction to protect the belt. Plus, a Slide-Out Service™ capability allows direct access to all the bars, making service—and installation—quick and convenient. Finally, our expert engineers evaluated all components and maximized the effectiveness of even the smallest details.

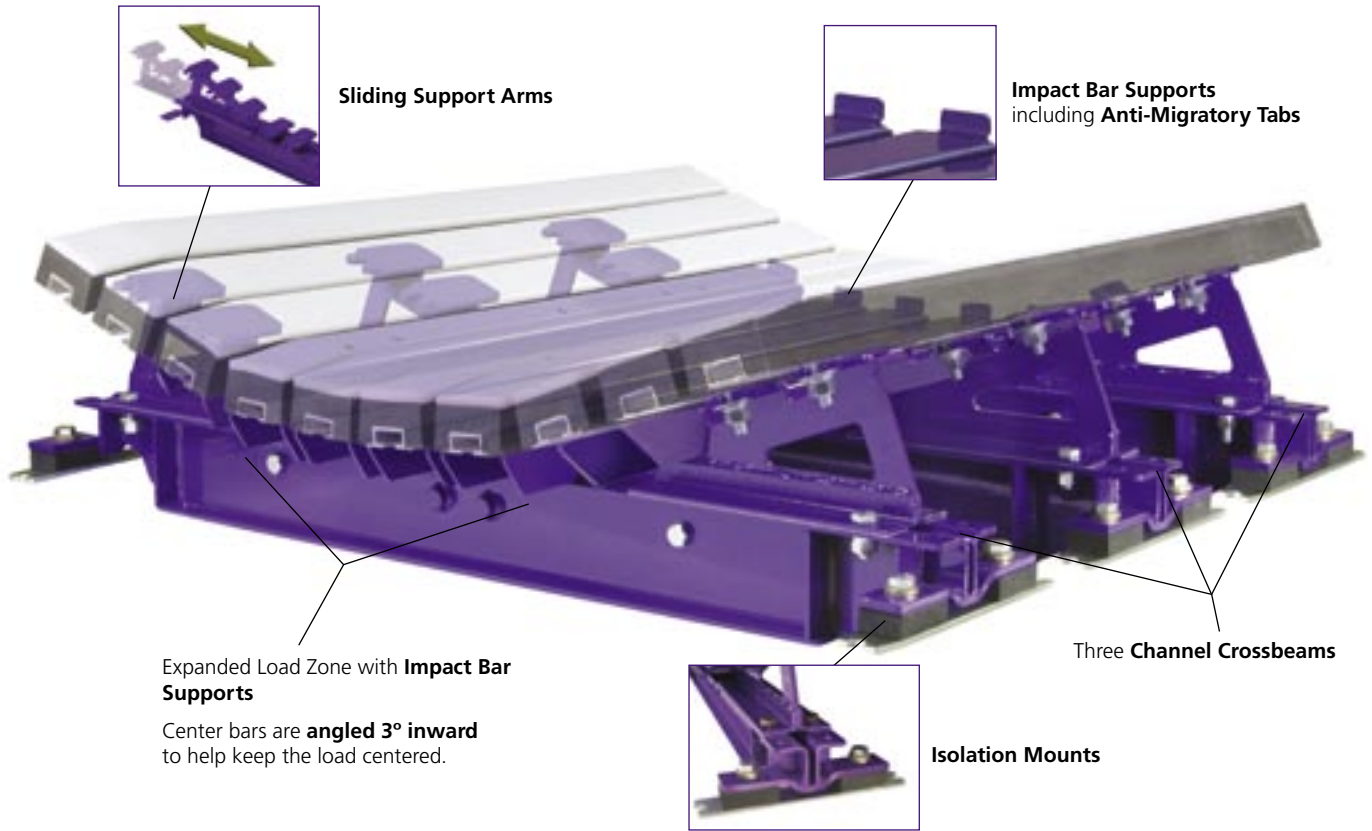

Xtra Belt Protection and Convenience.

The DRX750 separates in the middle and slides out for convenient, efficient maintenance. Our **Slide-Out Service™** means one person can convert your DRX bed from run position to maintenance position—or back again—in just minutes.

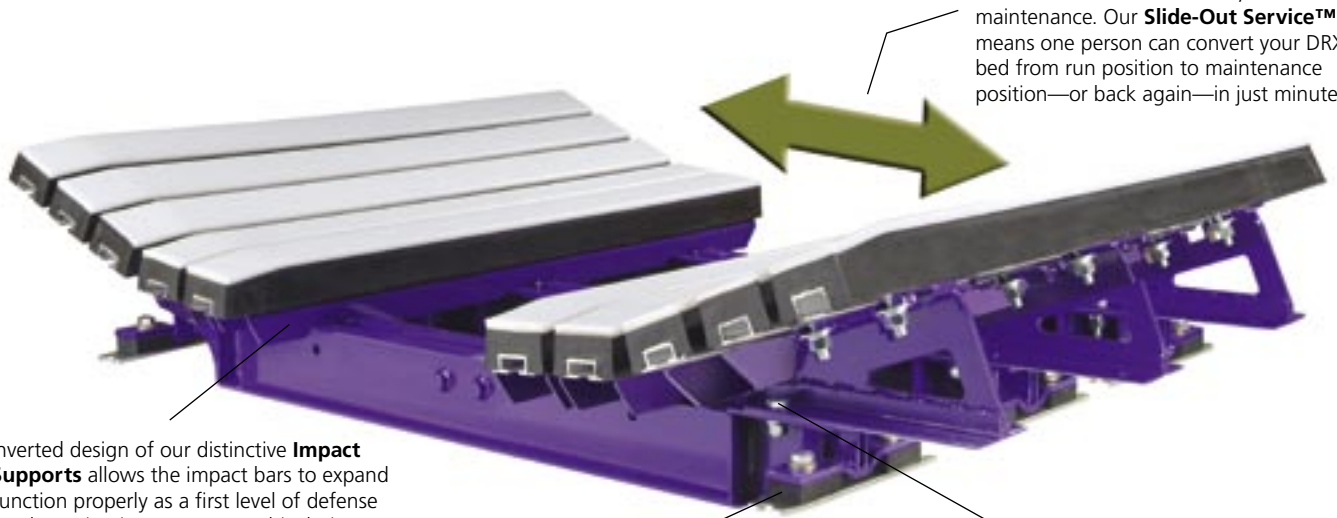

The inverted design of our distinctive **Impact Bar Supports** allows the impact bars to expand and function properly as a first level of defense against damaging impact energy. This design also maintains optimal clearance between the supports so fugitive material can fall through and not build up between bars. In addition, our supports are made from high-strength steel for maximum reliability.

Isolation Mounts provide a second level of reaction force reduction, minimizing damaging impact forces that can be transmitted back to the belt and the entire

When the two sides are moved out, a pair of **Positive Anchoring Bolts** ensures that each side remains secured for safety. When returned to the run position, the side assemblies easily engage a central locating pin, while the bolts



DRX750: Absorbing Impact to Save Your Belt.

DRX750—Designed to Exceed Your Needs.

Engineered specifically for hard rock and limestone operations, the DRX750 Impact Bed is intended for up to 750 lb-ft applications of impact energy. (See calculation chart below.) Generally recommended for -8" to -10" (-200mm to -250mm) material, or situations where the greatest dimension of the rock is less than ten inches, the DRX750 works with 24" – 72" (600mm – 1800mm) belts.

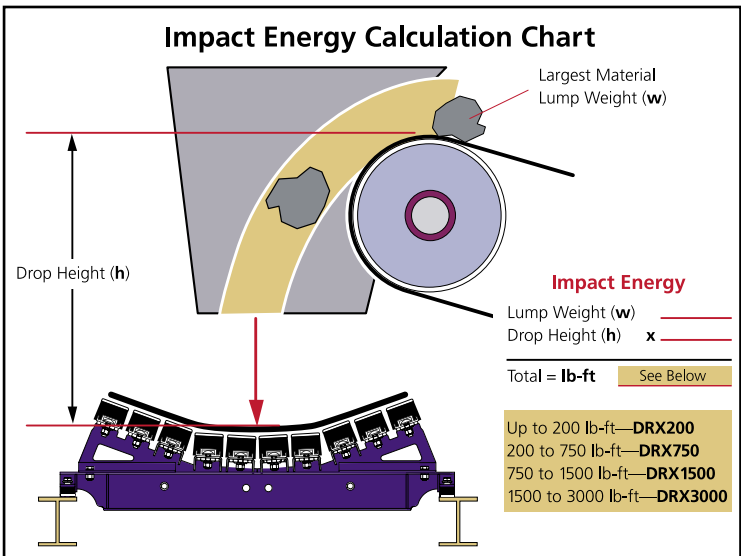

First Level Protection Goes Way Beyond the Bars.

With the DRX line, like other beds, impact bars first absorb impact energy and provide the initial reduction of reaction forces. However, our supports are superior to other bar supports. Our unique inverted-design Impact Bar Supports allow the impact bars to function properly—expanding and absorbing more impact energy. This makes our *first level* of defense extraordinarily effective at protecting the belt against damaging reaction forces.

Only DRX Offers a *Second Level* of Belt Protection.

In the DRX750, Isolation Mounts—located at the base of the bed—provide a *second level* of reaction force reduction, absorbing additional impact energy and minimizing transmission back to the belt.



Velocity Reduction Technology™ Extends Belt Life.

The DRX line features our exclusive Velocity Reduction Technology™ to protect the belt like no other system available today. This technology is engineered throughout the DRX structure providing two levels of relief that allow our beds to absorb more impact energy and reduce detrimental reaction forces better than other beds. Velocity Reduction Technology™ delivers:

- Less belt wear and reduced belt damage for longer belt life
- Less stress on bed and conveyor structures
- Less rebounding and material degradation

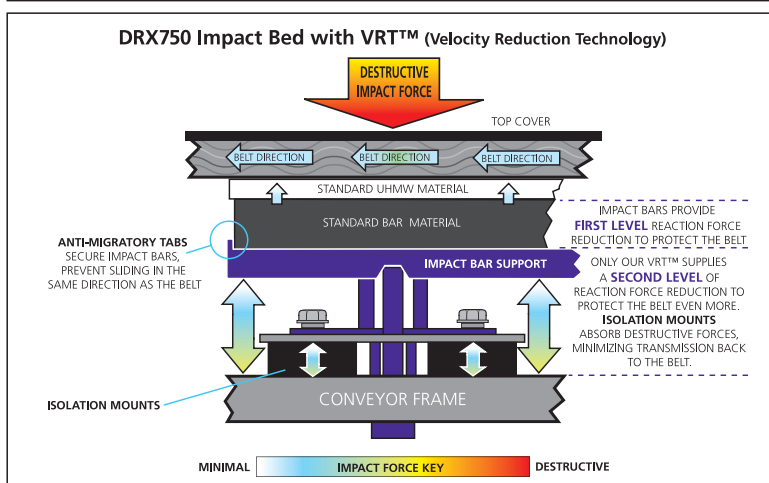
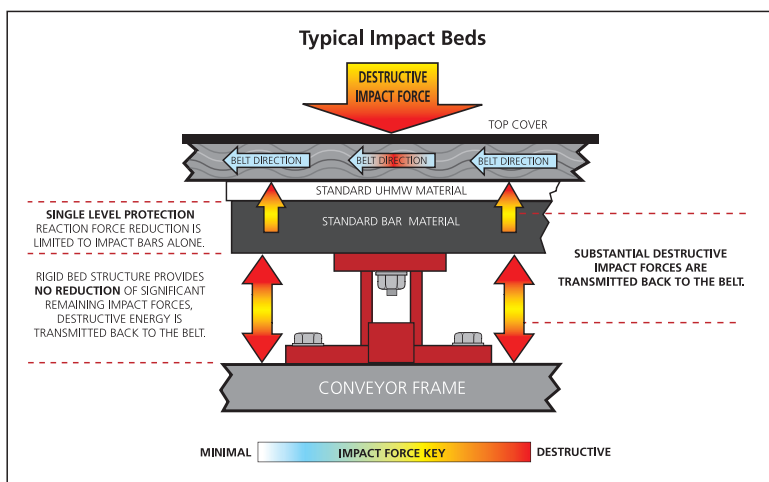



Slide-Out Service™ on the DRX750 Makes Maintenance Quick, Convenient and Safe.

The DRX750 Impact Bed separates in the middle, allowing the two sides to slide apart and out. Convenient Slide-Out Service™ gives direct access to all the bars and bolts for quick, easy and safe maintenance. The bed offers rapid conversion from run position to service position and back again. Other beds require that a two-man crew spend up to eight hours replacing the bars. With a DRX bed, that same crew can *finish a complete bar change out in just one to two hours*. Additionally, the DRX line is designed to work with any common rubber impact bar. Use existing stock and maintain a smaller inventory for future change outs.

Safety is also improved with a DRX bed. When the two sides are moved out, a pair of Positive Anchoring Bolts ensures that each side remains safely secured. When returned to the run position, the side assemblies easily engage with a central locating pin, while the bolts secure each side back in place.

Superior Impact Bar Supports Enhance Bar Function.

Made from high-strength steel, our distinctive inverted-design Impact Bar Supports let the impact bars expand, function properly and absorb more impact energy. This design also maintains optimal clearance between the supports so fugitive material can fall through and not build up. Finally, an Anti-Migratory Tab on each support bar secures the impact bar and prevents it from sliding in the same direction as the belt.

Channel Crossbeams Efficiently Transfer Impact Energy.

Our Channel Crossbeams feature gussets to tie the top and bottom flange together to improve the capacity and overall efficiency of the beams. This means we have lighter and stronger beams for your applications. Contoured ends on the Channel Crossbeams save vertical space and leave a thicker, more robust middle section to carry the load. All standard DRX Impact Beds use the same Channel Crossbeams. This allows us to keep a stocked inventory and reduces turnaround time.



Engineered Better—Down to the Details.

It's true—the devil is in the details. That's why even our smallest parts are designed to make your job easier and more productive.

- DRX Impact Beds use our exclusive, anti-spin Square Washers to attach the impact bars to the Impact Bar Supports. These innovative washers work with standard, inexpensive carriage bolts. If ever needed, carriage bolts can be torched off and replaced for pennies. Other beds require expensive T bolts.
- On all DRX beds the four center Impact Bars Supports tilt 3° inward. It's a subtle detail that helps center the load on the belt.
- DRX beds are powder coated for better corrosion resistance, more durable finish and a more attractive appearance.
- The full range of Flexco's DRX Impact Beds meets and exceeds CEMA standards.

Fast, On-time Shipping.

We can ship your DRX750 Impact Bed in just two weeks from our stocked inventory. Other beds routinely take three to five weeks to ship a bed, extending downtime and reducing your productivity.

Contact Us Today.

As a partner in your productivity, Flexco can help you determine the best impact bed to meet your individual need. With the DRX750 Impact Bed there are no data sheets to fill out. Just call your Flexco Field Engineer and give the lump size, drop height and roller size with the corresponding CEMA rating, and he will recommend the ideal bed for your specific application.



Xtra Safe, Convenient Installation.

Flexco's DRX Impact Beds were engineered for safety and convenience from the very beginning. Our rugged system breaks down into individual components that can be easily hand carried to the installation site. One or two people can lift each component into place. Only simple tools are required and the entire process takes a matter of hours.



STEP 1

Use template to measure and cut holes.



STEP 2

Parts can be moved into place by one to two people.



STEP 3

Set Channel Crossbeams into position on the structure.



STEP 4

Measure out proper Channel Crossbeam distance and put into place.



STEP 5

Bolt down the Channel Crossbeams.



STEP 6

Remove Support Arm mounting bolts and slide Support Arm to service position and rebolt.



STEP 7

Set bars in place over Support Arms.



STEP 8

Bolt bars to Support Arms.



STEP 9

Slide Support Arms from service position to run position.



STEP 10

Bolt Support Arms to Channel Crossbeams.



STEP 11

Clean up work area and remove tools.

DRX—Engineered to Perform Better From Top to Bottom.

Flexco's DRX Impact Beds set a new standard in performance. DRX beds have been carefully engineered to protect your belt and conveyor better than any other beds.

- **Velocity Reduction Technology™** is found only in the DRX line! Two levels of *reaction force reduction* absorb impact energy and minimize transmission back to the belt. Velocity Reduction Technology™ delivers longer belt life, less stress on the conveyor structure and reduced material degradation.
- **Slide-Out Service™** makes maintenance convenient and safe. DRX Impact Beds separate in the middle and the two sides slide apart. This provides direct access to all the bars and bolts for easy, quick and safe maintenance. A complete bar change out takes just one or two hours.
- **Impact Bar Supports** enhance bar function. Made from high-strength steel, our inverted-design Impact Bar Supports allow the impact bars to expand and function properly to absorb more impact energy.
- **Channel Crossbeams** efficiently transfer damaging impact energy. Contoured ends on the Channel Crossbeams save vertical space and leave a more robust middle section to carry the load.
- **Engineered Better**—down to the details. All components are designed to make your job easier and more productive.

We Thought of All the Xtras!



DRX200



DRX750

For heavy-duty applications—750 – 1500 lb-ft



DRX1500

DRX1500

Only DRX Beds Meet or Exceed CEMA Standards

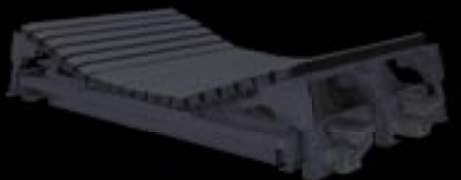
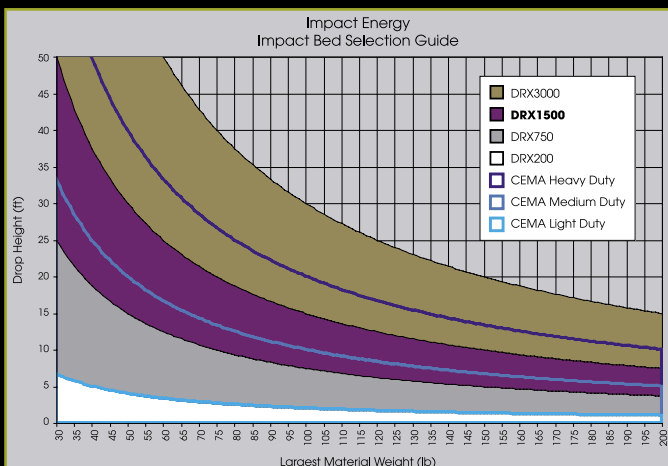

DRX3000

DRX1500 Impact Beds.

The DRX1500 Impact Bed is designed to meet the heavy-duty needs of coal-fired power plants, coal prep plants and load out facilities. The DRX1500 features Velocity Reduction Technology™ with two levels of effective reaction force reduction to protect the belt. Plus, a Slide-Out Service™ capability allows direct access to all the bars, making service—and installation—quick and convenient. Finally, our expert engineers evaluated all components and maximized the effectiveness of even the smallest details.

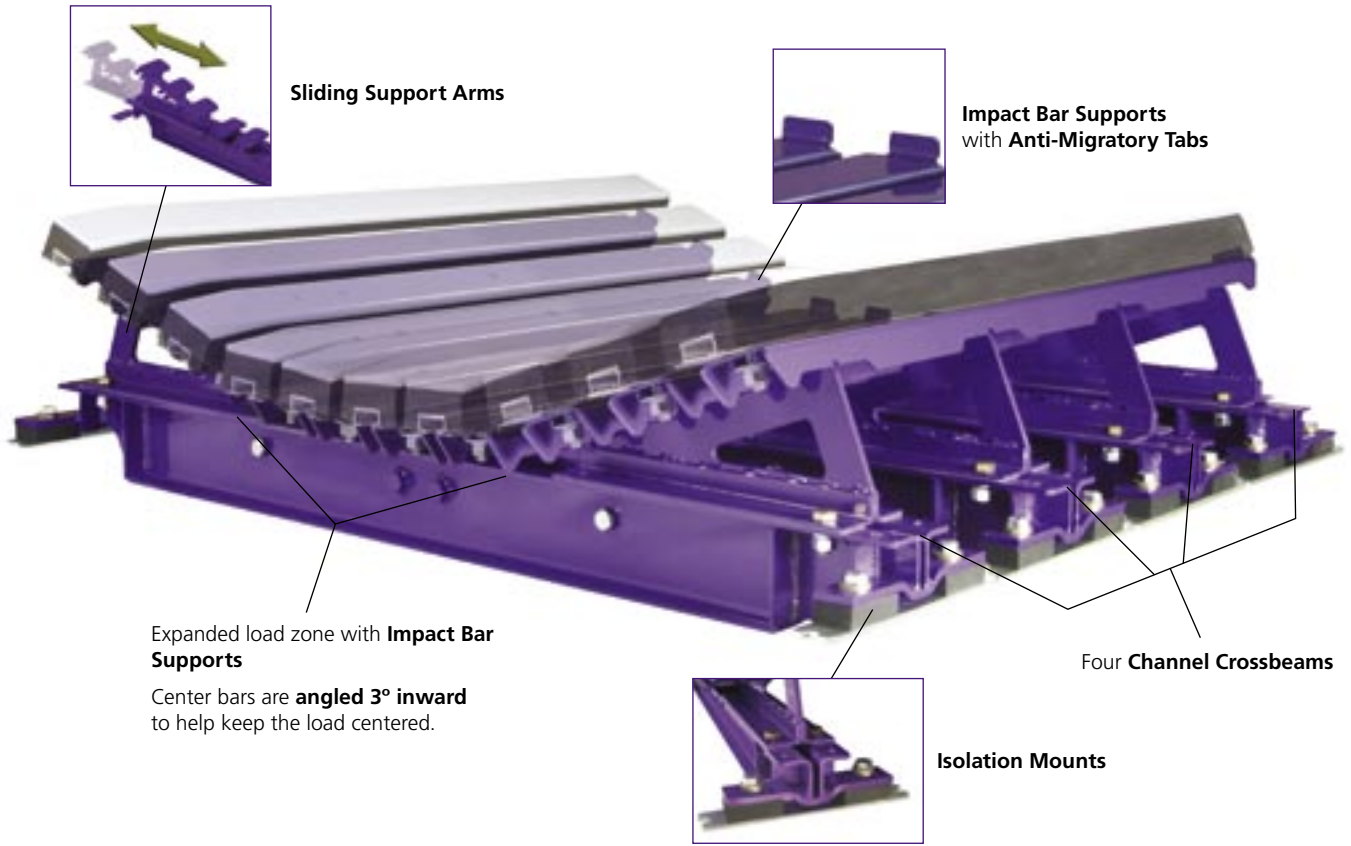

Sliding Support Arms

Impact Bar Supports with Anti-Migratory Tabs

Expanded load zone with **Impact Bar Supports**

Center bars are **angled 3° inward** to help keep the load centered.

Four **Channel Crossbeams**

Isolation Mounts

DRX1500

Xtra Belt Protection and Convenience.

The DRX1500 separates in the middle and slides out for convenient, efficient maintenance. Our **Slide-Out Service™** means one person can convert your DRX bed from run position to maintenance position—or back again—in just minutes.

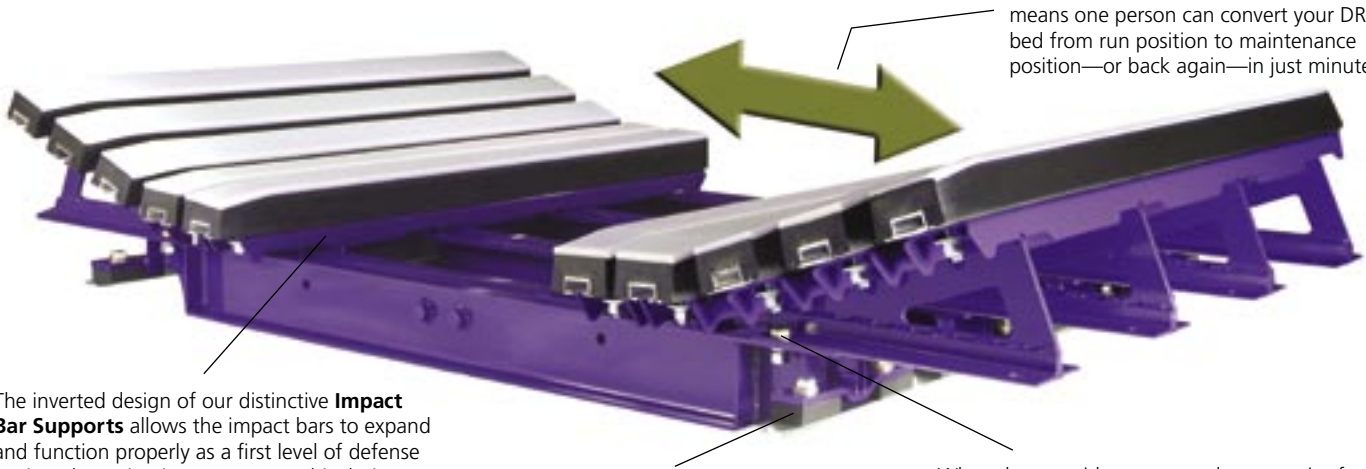

The inverted design of our distinctive **Impact Bar Supports** allows the impact bars to expand and function properly as a first level of defense against damaging impact energy. This design also maintains optimal clearance between the supports so fugitive material can fall through and not build up between bars. In addition, our supports are made from high-strength steel for maximum durability.

Isolation Mounts provide a second level of reaction forces reduction, minimizing damaging impact forces that can be transmitted back to the belt and the entire conveyor system.

When the two sides are moved out, a pair of **Positive Anchoring Bolts** ensures that each side remains secured for safety. When returned to the run position, the side assemblies easily engage a central locating pin, while the bolts secure each side back in place.



DRX1500: Deadening Impact and Absorbing Energy.

DRX1500—Designed for Heavy-Duty Protection.

Engineered for coal-fired power plants, coal prep plants and load out facilities, the DRX1500 Impact Bed is intended for up to 1500 lb-ft applications of impact energy. (See calculation chart below.) Generally recommended for -12" (-300mm) material, or situations where the greatest dimension of the rock is less than twelve inches, the DRX1500 works with 24" – 72" (600mm – 1800mm) belts.

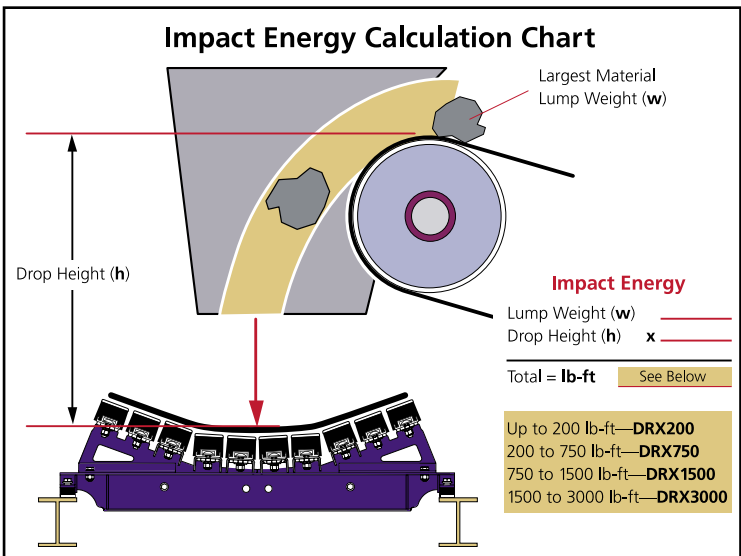

First Level Protection Goes Way Beyond the Bars.

With the DRX line, like other beds, impact bars first absorb impact energy and provide the initial reduction of reaction forces. However, our supports are superior to other bar supports. Our unique inverted-design Impact Bar Supports allow the impact bars to function properly—expanding and absorbing more impact energy. This makes our *first level* of defense extraordinarily effective at protecting the belt against damaging reaction forces.

Only DRX Offers a *Second Level* of Belt Protection.

In the DRX1500, Isolation Mounts—located at the base of the bed—provide a *second level* of reaction force reduction, absorbing additional impact energy and minimizing transmission back to the belt.

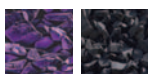

Velocity Reduction Technology™ Extends Belt Life.

The DRX line features our exclusive Velocity Reduction Technology™ to protect the belt like no other system available today. This technology is engineered throughout the DRX structure providing two levels of relief that allow our beds to absorb more impact energy and reduce detrimental reaction forces better than other beds. Velocity Reduction Technology™ delivers:

- Less belt wear and reduced belt damage for longer belt life
- Less stress on bed and conveyor structures
- Less rebounding and material degradation

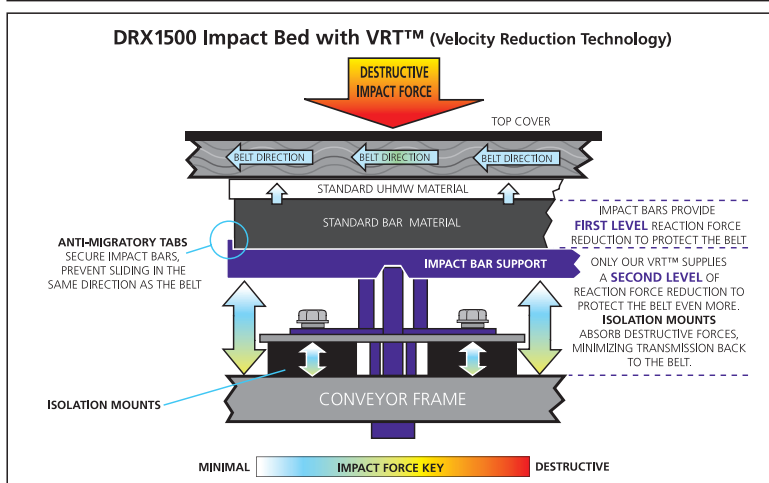
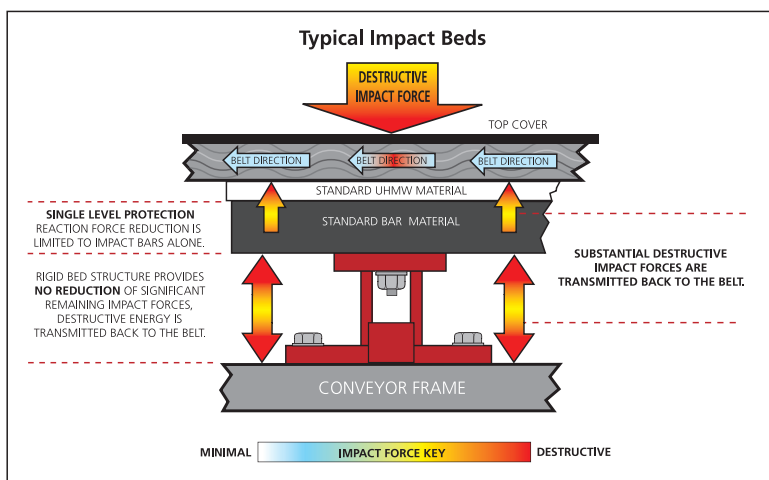



Slide-Out Service™ on the DRX1500 Makes Maintenance Quick, Convenient and Safe.

The DRX1500 Impact Bed separates in the middle, allowing the two sides to slide apart and out. This handy Slide-Out Service™ gives direct access to all the bars and bolts for quick, easy and safe maintenance. The bed offers rapid conversion from run position to service position and back again. Other beds require that a two-man crew spend up to eight hours replacing the bars. With a DRX bed, that same crew can *finish a complete bar change out in just one to two hours*. Further, the DRX line works with any common rubber impact bar. Use existing stock and maintain a smaller inventory for future change outs.

Safety is also improved with a DRX bed. When the two sides are moved out, a pair of Positive Anchoring Bolts ensures that each side remains secured. When returned to the run position, the side assemblies easily engage with a central locating pin, while the bolts secure each side back in place.

Superior Impact Bar Supports Enhance Bar Function.

Made from high-strength steel, our distinctive inverted-design Impact Bar Supports allow the impact bars to expand and function properly to absorb more impact energy. This design also maintains optimal clearance between the supports so fugitive material can fall through and not build up. Plus, an Anti-Migratory Tab on each support bar secures the impact bar and prevents it from sliding in the same direction as the belt.

Channel Crossbeams Efficiently Transfer Impact Energy.

Our Channel Crossbeams include gussets to tie the top and bottom flange together to improve the capacity and overall efficiency of the beams. This means we have lighter and stronger beams for your applications. Contoured ends on the Channel Crossbeams save vertical space and leave a thicker, more robust middle section to carry the load. All standard DRX Impact Beds use the same Channel Crossbeams. This allows us to keep a stocked inventory and reduces turnaround time.



Engineered Better—Down to the Details.

It's true—the devil is in the details. That's why even our smallest parts are designed to make your job easier and more productive.

- DRX Impact Beds use our exclusive, anti-spin Square Washers to attach the impact bars to the Impact Bar Supports. These innovative washers work with standard, inexpensive carriage bolts. If ever needed, carriage bolts can be torched off and replaced for pennies. Other beds require expensive T bolts.
- On all DRX beds the four center Impact Bars Supports tilt 3° inward. It's a subtle detail that helps center the load on the belt.
- DRX beds are powder coated for better corrosion resistance, more durable finish and a more attractive appearance.
- The full range of Flexco's DRX Impact Beds meets and exceeds CEMA standards.

Fast, On-time Shipping.

We can ship your DRX1500 Impact Bed in just two weeks from our stocked inventory. Other beds routinely take three to five weeks to ship a bed, extending downtime and reducing your productivity.

Contact Us Today.

As a partner in your productivity, Flexco can help you determine the best impact bed to meet your individual need. With the DRX1500 Impact Bed there are no data sheets to fill out. Just call your Flexco Field Engineer and give the lump size, drop height and roller size with the corresponding CEMA rating, and he will recommend the ideal bed for your specific application.



Xtra Safe, Convenient Installation.

Flexco's DRX Impact Beds were engineered for safety and convenience from the very beginning. Our rugged system breaks down into individual components that can be easily hand carried to the installation site. One or two people can lift each component into place. Only simple tools are required and the entire process takes a matter of hours.



STEP 1

Use template to measure and cut holes.



STEP 2

Parts can be moved into place by one to two people.



STEP 3

Set Channel Crossbeams into position on the structure.



STEP 4

Measure out proper Channel Crossbeam distance and put into place.



STEP 5

Bolt down the Channel Crossbeams.



STEP 6

Remove Support Arm mounting bolts and slide Support Arm to service position and rebolt.



STEP 7

Set bars in place over Support Arms.



STEP 8

Bolt bars to Support Arms.



STEP 9

Slide Support Arms from service position to run position.



STEP 10

Bolt Support Arms to Channel Crossbeams.



STEP 11

Clean up work area and remove tools.

DRX—Engineered to Perform Better From Top to Bottom.

Flexco's **DRX Impact Beds** set a new standard in performance. DRX beds have been carefully engineered to provide convenient service and protect your belt and conveyor better than any other beds.

- **Velocity Reduction Technology™** is found only in the DRX line! Two levels of *reaction force reduction* absorb impact energy and minimize transmission back to the belt. Velocity Reduction Technology™ delivers longer belt life, less stress on the conveyor structure and reduced material degradation.
- **Slide-Out Service™** makes maintenance convenient and safe. DRX Impact Beds separate in the middle and the two sides slide apart. This provides direct access to all the bars and bolts for easy, quick and safe maintenance.
- **Impact Bar Supports** enhance bar function. Made from high-strength steel, our inverted-design Impact Bar Supports allow the impact bars to expand and function properly to absorb more impact energy.
- **Channel Crossbeams** efficiently transfer damaging impact energy. Contoured ends on the Channel Crossbeams save vertical space and leave a more robust middle section to carry the load.
- **Engineered Better**—down to the details. All components are designed to make your job easier and more productive.

We Thought of All the Xtras!



DRX200



DRX750



DRX1500

Only DRX Beds Meet or Exceed CEMA Standards

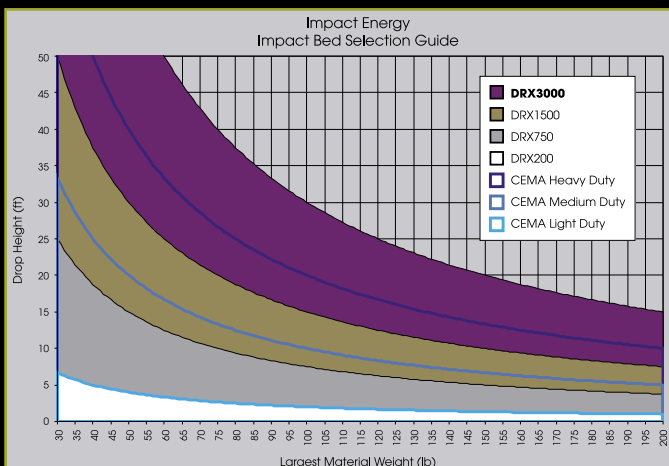

For extreme applications—
1500 – 3000 lb. ft.



DRX3000

DRX3000

DRX3000 Dynamic Impact Beds.

For those rare applications that combine large size material and a severe fall height, DRX3000 Dynamic Impact Beds offer extreme performance. The DRX3000 Dynamic features Velocity Reduction Technology™ with two levels of effective reaction force reduction to protect the belt. Plus, a Slide-Out Service™ capability allows direct access to all the bars, making service—and installation—quick and convenient. Finally, our expert engineers evaluated all components and maximized the effectiveness of even the smallest details.

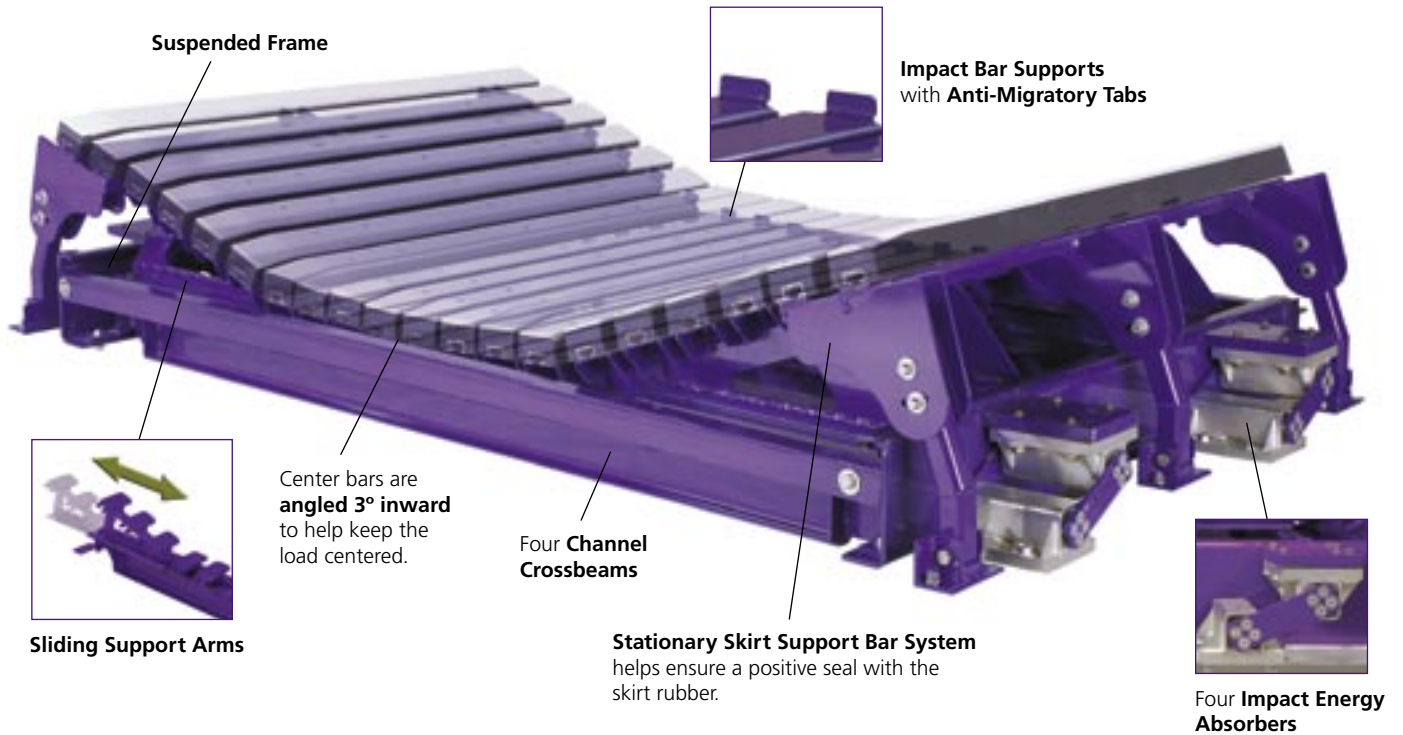

Suspended Frame

Impact Bar Supports with Anti-Migratory Tabs

Center bars are angled 3° inward to help keep the load centered.

Four Channel Crossbeams

Sliding Support Arms

Stationary Skirt Support Bar System helps ensure a positive seal with the skirt rubber.

Four Impact Energy Absorbers

Xtra Extreme Belt Protection and Convenience.

When the two sides are moved out, they rest on the side rails for safe and secure access. When returned to run position, the side assemblies easily engage with a central locating pin, while the bolts secure each side back in place.

The DRX3000 Dynamic separates in the middle and slides out for convenient, efficient maintenance. Our **Slide-Out Service™** means the bed can convert from run position to maintenance position—or back again—with minimal disassembly.

Our **Stationary Skirt Support Bar System** holds the outer bars in a fixed position to work with skirting systems. This major benefit keeps the skirt rubber in contact with the belt to seal dust and contain spillage. The Skirt Support Bar Arm allows the system to be easily removed for access to impact bars for maintenance.

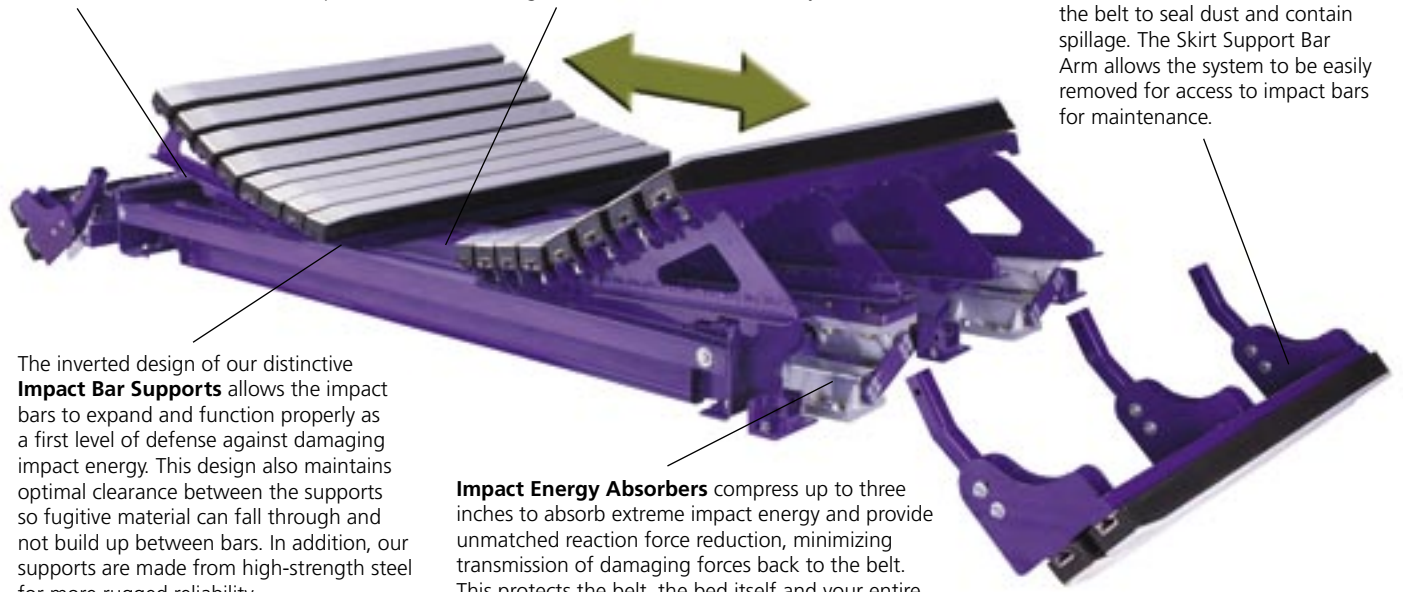

The inverted design of our distinctive **Impact Bar Supports** allows the impact bars to expand and function properly as a first level of defense against damaging impact energy. This design also maintains optimal clearance between the supports so fugitive material can fall through and not build up between bars. In addition, our supports are made from high-strength steel for more rugged reliability.

Impact Energy Absorbers compress up to three inches to absorb extreme impact energy and provide unmatched reaction force reduction, minimizing transmission of damaging forces back to the belt. This protects the belt, the bed itself and your entire

DRX3000



DRX3000 Dynamic: Unmatched Energy Absorption and Belt Protection.

DRX3000 Dynamic—Designed to Save Your System.

Specifically designed to meet the exceptional needs of impact areas requiring extreme energy absorption, the DRX3000 Dynamic Impact Bed is intended for up to 3000 lb-ft applications of impact energy (See calculation chart below.) with a 42" – 96" (1050mm – 2400mm) belt.

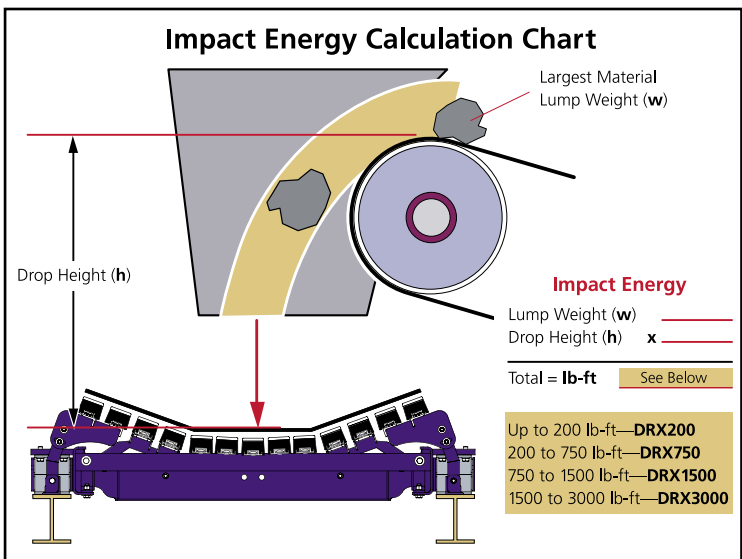

First Level Protection Goes Way Beyond the Bars.

With the DRX line, like other beds, impact bars first absorb impact energy and provide the initial reduction of reaction forces. However, our supports are superior to other bar supports. Our unique inverted-design Impact Bar Supports allow the impact bars to function properly—expanding and absorbing more impact energy. This makes our *first level* of defense extraordinarily effective at protecting the belt against damaging reaction forces.

Only the DRX3000 Dynamic Offers an Xtreme Second Level of Belt Protection.

The DRX3000 Dynamic includes a fully-suspended frame and Impact Energy Absorbers to disperse an immense amount of impact energy and reduce damaging impact forces transmitted back to the belt. This provides an unmatched *second level* of belt protection for extremely severe situations.



Velocity Reduction Technology™ Extends Belt Life.

The DRX line features our exclusive Velocity Reduction Technology™ to protect the belt like no other system available today. This technology, incorporating our revolutionary Impact Energy Absorbers, is engineered throughout the DRX structure providing two levels of relief that allow our beds to absorb more impact energy and reduce detrimental reaction forces better than other beds. Velocity Reduction Technology™ delivers:

- Less belt wear and reduced belt damage for longer belt life
- Less stress on bed and conveyor structures
- Less rebounding and material degradation

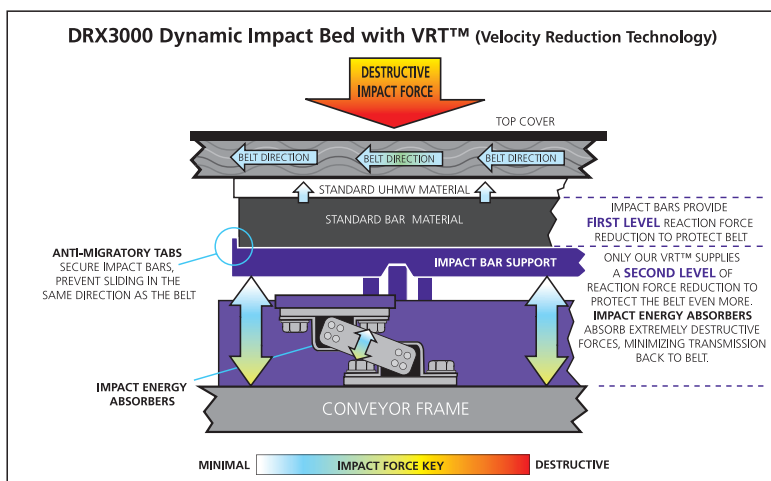
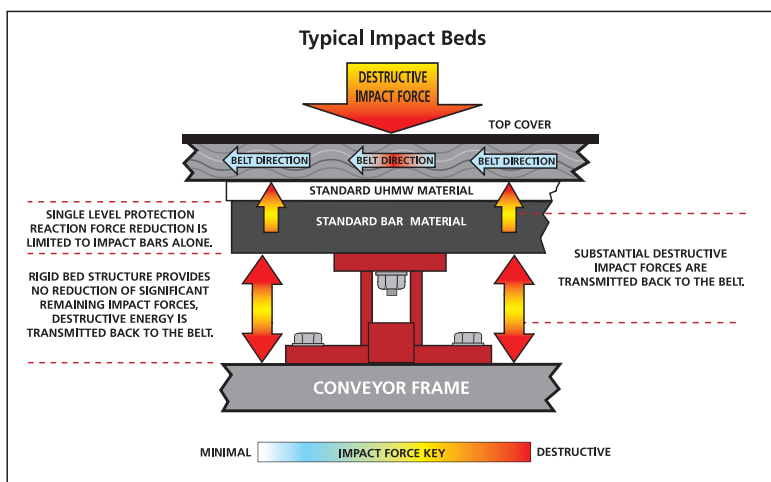



Slide-Out Service™ on the DRX3000 Dynamic Makes Maintenance Quick, Convenient and Safe.

The DRX3000 Dynamic Impact Bed separates in the middle, allowing the two sides to slide apart and out. This unique Slide-Out Service™ gives direct access to all the bars and bolts for quick, easy and safe maintenance. Once the halves have been moved out and up, bar replacement is straightforward. Further, the DRX line is designed to work with any common rubber impact bar. Use existing stock and maintain a smaller inventory for future change outs.

Safety is also improved with a DRX bed. When the two sides are moved out, they rest on the side rail for safe and secure access. When returned to the run position, the side assemblies easily engage with a central locating pin, while the bolts secure each side back in place.

Superior Impact Bar Supports Enhance Bar Function.

Made from high-strength steel, our distinctive inverted-design Impact Bar Supports allow the impact bars to expand and function properly to absorb more impact energy. This design also maintains optimal clearance between the supports so fugitive material can fall through and not build up between bars. Plus, an Anti-Migratory Tab on each support bar secures the impact bar and prevents it from sliding in the same direction as the belt.

Channel Crossbeams Efficiently Transfer Impact Energy.

Our Channel Crossbeams feature gussets to tie the top and bottom flange together to improve the capacity and overall efficiency of the beams. This means we have lighter and stronger beams for your applications. Contoured ends on the Channel Crossbeams save vertical space and leave a thicker, more robust middle section to carry the load.



Engineered Better—Down to the Details.

It's true—the devil is in the details. That's why even our smallest parts are designed to make your job easier and more productive.

- DRX Impact Beds use our exclusive, anti-spin Square Washers to attach the impact bars to the Impact Bar Supports. These innovative washers work with standard, inexpensive carriage bolts. If ever needed, carriage bolts can be torched off and replaced for pennies. Other beds require expensive T bolts.
- On all DRX beds the four center Impact Bars Supports tilt 3° inward. It's a subtle detail that helps center the load on the belt.
- DRX beds are powder coated for better corrosion resistance, more durable finish and a more attractive appearance.
- The full range of Flexco's DRX Impact Beds meets and exceeds CEMA standards.

Fast, On-time Shipping.

Shipping times for our DRX3000 Dynamic Impact Beds are generally four weeks.

Contact Us Today.

As a partner in your productivity, Flexco can help you determine the best impact bed to meet your individual need. With the DRX3000 Dynamic Impact Bed there are no data sheets to fill out. Just call your Flexco Field Engineer and give the lump size, drop height and roller size with the corresponding CEMA rating, and he will recommend the ideal bed for your specific application.



Xtra Safe, Convenient Installation.

Flexco's DRX Impact Beds were engineered for safety and convenience from the very beginning. Our rugged system breaks down into individual components that can be easily hand carried to the installation site. One or two people can lift each component into place. Only simple tools are required and the entire process takes a matter of hours.



STEP 1

Set rosta rail on structure, center, square up with cross braces and weld in place.



STEP 2

Compress rostas to gain 2.5" of additional space.



STEP 3

Remove Support Arms from Channel Crossbeams.



STEP 4

Set Channel Crossbeams into position and bolt.



STEP 5

Bolt Support Arms into service position.



STEP 6

Set bars in place and bolt.



STEP 7

Slide Support Arms in and bolt.



STEP 8

Set Skirt Support Bar in place and weld to structure.



STEP 9

Adjust height and angle of Stationary Support Bar Arm.



STEP 10

Clean up work area and remove tools.

A Full Line of Conveyor Solution Products.

Impact Zone

Flex-Lifter™ Conveyor Belt Lifter



Lifting a tensioned conveyor belt to replace worn idlers or to set up a splicing station can be a difficult and hazardous job. The Flex-Lifter makes the job safe, fast and easy. Two Flex-Lifters are needed to elevate the front and rear of a load zone to make impact bed installations safer and more efficient.

Flex-Lok™ Skirt Clamps

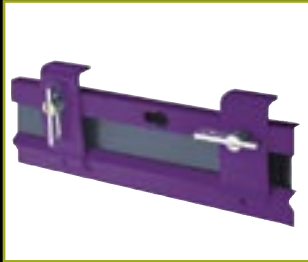

Our versatile skirt clamp design makes it easy to eliminate loading-point spillage on any conveyor loading site—even in severe heavy-loading applications.

Flex-Seal™ Skirting System



The Flex-Seal Skirting System is a dynamic containment unit that fully seals the loading zone. It stops material spillage leaks, controls dust emissions and eliminates resulting problems such as mistracking and belt damage.

Belt Control

PT Max™ Belt Trainer



Our PT Max employs our patented "pivot and tilt" action that provides a greater training influence on the belt. Top-side and return-side models

Positioner™ Belt Tracker



The Positioner works on the return side belt using simple angled rollers mounted in a fixed position to quickly and continuously funnel the belt into

Service You Will Count On from a Name You Trust.

Flexco professionals can inspect, recommend, install, maintain and troubleshoot conveyor components for your beltlines. We offer trusted Flexco products to ensure the job is done quickly and correctly, minimizing downtime and expense.

Our service offering includes:

- No-cost beltline surveys—we walk your belts
- Recommendations to solve problems and make improvements
- Routine beltline inspections—pre-quote for work to be done
- Scheduled maintenance and local inventory
- Emergency troubleshooting and repair
- Training—both hands-on and classroom

We offer more than just products alone—we partner with you to provide common sense thinking combined with state-of-the-art products to solve your problems. Our service means good solutions, delivered quickly and within your budget.

Contact Us Today!

For more on Flexco DRX Impact Beds—or any other quality Flexco product or service—contact your local Flexco distributor, or call us directly.

Flexco Customer Service: (800) 541-8028
Hours: 7:00 am-5:30 pm CST Monday-Friday
FAX: (630) 971-1180
E-mail: info@flexco.com

2525 Wisconsin Avenue
Downers Grove, IL 60515

©2008 Flexible Steel Lacing Company. Dual Relief Xtra™, Velocity Reduction Technology™, Slide-Out Service™, Flex-Lifter™, Flex-Lok™ Flex-Seal™, PT Max™ and Positioner™ are trademarks of Flexible Steel Lacing Company. Released 1/08 For reorder: Item Code X1595

www.flexco.com



GOODYEAR
RUBBER PRODUCTS INC.

Call Toll Free: 1-866-711-4673
WebSales@GoodyearRubberProducts.com

**We Ship
World Wide**