

Portable hand-held digital gauge for accurate pressure measurements

- Easy operation
- Accuracy of 0.5% FS
- MIN/MAX value memory
- 3 pressure ranges
- 3 Volt battery power supply
- Large LCD display
- Auto-Off function
- Zero adjust feature
- Rugged design



The **ServiceJunior™** is a hand-held digital pressure-measuring device that provides quick, accurate and easy-to-read pressure measurements.

The 0.5% FS (full-scale) accuracy range offers a reliable measurement you can depend on. In addition, the 500ms scanning rate allows the unit to capture and store both minimum and maximum pressure readings, as well as momentary pressure spikes.

The menu buttons on the **ServiceJunior™** provide for easy operation of Min/Max measurements, Zero Adjust and On-Off features. A single 3-Volt internal battery, with an estimated life cycle of 1500 hours, powers the large 4-digit LCD display.

The **ServiceJunior™** is available in three convenient pressure ranges: -14.5 to 435 psi, 0 to 4350 psi, and 0-8700 psi. Several quick coupling port options make diagnostic connections a *snap*.

For more information or to receive a full demonstration, contact the Quick Coupling Division or your local distributor.

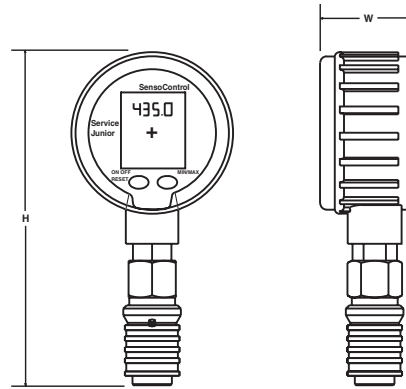

Specifications

Accuracy.....	0.5% Full Scale Typical
Compensated Temperature Range.....	32°F to 122°F
Operating/Storage Temperature Range.....	-22°F to 122°F
Min/Max Scanning Rate.....	500 ms
Battery Life (Estimated)	1500 hours
Protection Class.....	IP65
Standard Auto Shut-Off.....	20 minutes
Display.....	Back-lit 4-digit LCD
Housing.....	Thermoplastic

Technical Data

Part Number	Diameter	Height (H)	Width (W)	Weight
SCM-050-0*-PD (With PD Coupler)	2.77"	5.80"	1.65"	9.3 oz.
SCM-050-0*-EMA (With EMA Coupler)	2.77"	5.17"	1.65"	8.6 oz.
SCM-050-0*-4MP (With 1/4" NPT Port)	2.77"	4.90"	1.65"	6.5 oz.

Note: (*) Denotes pressure range. See table below for complete part number

Digital Gauge/Coupler Assemblies Ordering Code

Measuring Range	Digital Gauge with PD Coupler	Digital Gauge with EMA3 Coupler	Digital Gauge with 1/4" NPT Port	Maximum Pressure	Resolution
-14.5 to 435 psi (-1 to 30 Bar)	SCM-050-01-PD	SCM-050-01-EMA	SCM-050-01-4MP	480 PSI	0.1 PSI
0 to 4350 psi (0 to 300 Bar)	SCM-050-02-PD	SCM-050-02-EMA	SCM-050-02-4MP	4800 PSI	1 PSI
0 to 8700 psi (0 to 600 Bar)	SCM-050-03-PD ⁽¹⁾	SCM-050-03-EMA ⁽²⁾	SCM-050-03-4MP	9600 PSI	10 PSI

Note: (1) Maximum Rated Pressure for PD Series Couplers is 6,000 PSI. (2) Maximum Rated Pressure for EMA Series Couplers is 9,000 PSI.

Accessories

Part Number	Description
SCJA-1/4	7/16-18 UNF-2B female to 1/4" NPT male adapter
PDH-19	19" PD Hose extension to be used with PD nipple interface
SCA-7/16-EMA-3	7/16-18UNF-2B female to M16X2.0 EMA3 female swivel
SCC-050	Storage case for one gauge and diagnostic adapters
SCC-100	Storage case for two gauges and diagnostic adapters

Quick Coupling Division