

4041 SERIES

FULL PORT FORGED BRASS UNI-FLANGE BALL VALVE with DRAIN - IPS x FLANGE x HOSE (600 WOG/150 WSP) - ISO 9001



PATENTED TECHNOLOGY

Designed for residential and commercial use with all 2 bolt flanged circulator pumps. The unitary construction of the brass body and flange provide strength and versatility for any application where a pipe and flange meet. This valve is the only choice to use in a closed system where a large port drain and fill valve is required. The approved valve features a hard chrome plated solid brass ball with reinforced Teflon® seats. The valve is actuated by a blowout proof stem with a Teflon® seal that features an adjustable packing nut. Vinyl coated stamped steel handle. Additional wing style "T" handle included with mounting nuts and bolts.



Flanges configured for high velocity pumps, add HV as a suffix to the end of the item number. Sizes 1" through 2". See G through L dimensions on HV*.

HIGH VELOCITY PUMP OPTION

4041HV SERIES

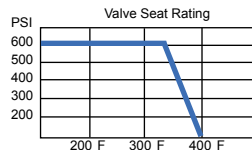

all Teflon® seated valves
Maximum Temperature is 400°F @ 100 PSI*

PRESSURE RATING
600 WOG non-shock
150 WSP

1. Threaded ends comply with ANSI B1 20.1
2. Hose end complies with ANSI B1.20.7
3. Manufactured in an ISO 9001 Facility

Specifications

Approved pump Isolation flanged valves shall be 2-piece design constructed of brass unibody flange and two end caps. Seats shall be Teflon® (PTFE). Stems shall be brass with a Teflon® (PTFE) seat secured with a brass packing gland to adjust handle actuation tension and prevent leakage for the life of the valve. Valve shall be rated 600WOG. The valve shall be a Webstone Company, Inc. Isolator® or Isolator® with drain.

The Isolator® is a registered trademark of Webstone Company Inc.
Teflon® is a registered trademark of Dupont.

THIS SPACE FOR DESIGNER / ENGINEER APPROVAL

Job/Customer _____	Date _____	Contractor _____
Model Specified _____	Qty _____	Approved By _____
Designer/Engineer _____	Date _____	Contractor's PO # _____
Submitted by _____	Date _____	Other _____

1.	FLANGED BODY	FORGED BRASS (ASTM B283-C37700)
2.	END CAP	FORGED BRASS (ASTM B283-C37700)
3.	SEATS	TEFLON® (PTFE)
4.	BALL	BRASS/HARD CHROME PLATE
5.	STEM	BRASS (ASTM B124-C37700)
6.	STEM SEAL	TEFLON® (PTFE)
7.	PACKING GLAND	BRASS (ASTM B124-C37700)
8.	LEVER HANDLE	C.P. STEEL
8a.	WING STYLE "T" HANDLE	C.P. STEEL/VINYL GRIPS
9.	HANDLE NUT	BRASS (ASTM B124-37700)
10.	HANDLE JACKET	VINYL GRIP
11.	SEAT RETAINER	BRASS (ASTM B124-C37700)
12.	HOSE THREADED END CAP	FORGED BRASS (ASTM B283-C37700)
13.	DRAIN VALVE SEATS	TEFLON® (PTFE)
14.	DRAIN VALVE BALL	BRASS/HARD CHROME PLATE
15.	DRAIN VALVE STEM	BRASS (ASTM B124-C37700)
16.	DRAIN VALVE STEM SEAL	TEFLON® (PTFE)
17.	DRAIN VALVE HANDLE	ENAMEL COATED ALUMINUM
18.	CAP AND CHAIN	BRASS (ASTM B124-C37700) w/NBR HOSE WASHER
19.	MOUNTING BOLTS AND NUTS	STEEL

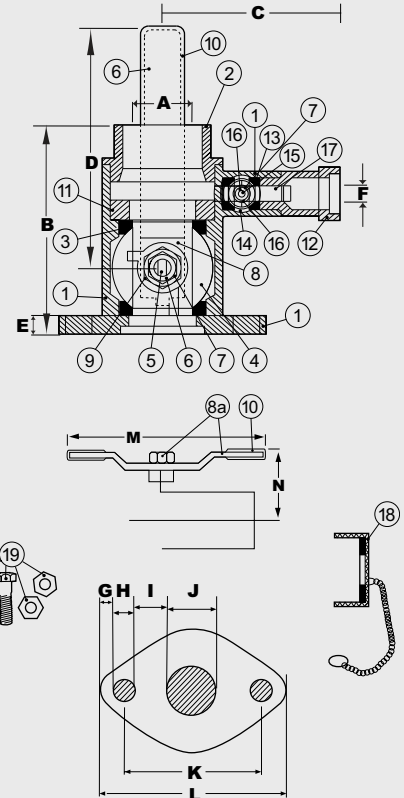

FLANGE FOR HIGH VELOCITY PUMP MODELS
excluding the 2nd model

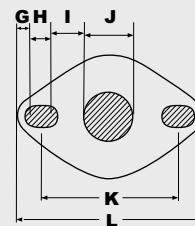

ITEM	SIZE	CTN/CS	A	B	C	D	E	F
40413	3/4	2/20	3/4	2 1/4	2 1/4	4	3/8	1/2
40414	1	2/20	15/16	2 1/2	2 1/2	4 5/8	3/8	1/2
40415	1 1/4	2/20	1 1/4	2 13/16	2 3/4	4 5/8	3/8	3/4
40416	1 1/2	2/20	1 1/2	5 1/16	3 1/2	5 9/16	3/8	3/4
40417HV	2	2/20	2	5 9/16	3 3/8	5 15/16	3/8	3/4

ITEM	G	H	I	J	K	L	M	N	C _v
40413	1/4	1/2	3/4	1 1/8	3 1/4	4 1/8	3 7/8	2 1/4	11.47
40414	1/8	5/8	5/8	1 5/16	3 3/8	4 1/8	4 4/16	2	24.01
40415	1/8	5/8	1/2	1 5/8	3 3/8	4 1/8	4 1/8	2 3/8	49.30
40416	1/4	1/2	5/16	1 15/16	3 1/4	4 3/16	4 1/8	2 3/4	161.30
40417HV	1/8	11/16	5/8	1 3/4	3 1/2	4 9/16	2 5/16	2 15/16	248.61
HV*	1/8	11/16	5/8	1 3/4	3 1/2	4 9/16	*	*	*

* All High Velocity valves share E, G, H, I, J, K and L measurements (except 40417HV).