

5040 SERIES

FULL PORT FORGED BRASS BALL VALVE - SWT x FLANGE (600 WOG/150 WSP) - ISO 9001



Designed for residential and commercial use with water or oil. The forged brass body and flange provide strength and versatility for any application where a pipe and flange meet. This approved Webstone valve features a solid hard chrome plated brass ball with reinforced Teflon® seats and a blowout proof stem sealed with Teflon® (PTFE) and an adjustable packing gland. Vinyl coated stamped steel handle. Ideal for use with circulating pumps. The solid brass flange when seated with a rubber gasket eliminates the problem of electrolysis commonly incurred when the use of an iron flange is connected to copper tubing. Additional wing style "T" handle included with mounting nuts and bolts.



Flanges configured for high velocity pumps, add HV as a suffix to the end of the item number. Sizes 1" through 2". See G through L dimensions on HV*.

HIGH VELOCITY PUMP OPTION

5040HV SERIES

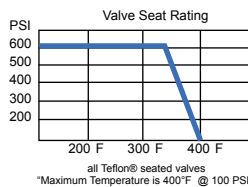

PRESSURE RATING
600 WOG non-shock
150 WSP

1. Threaded ends comply with ANSI B1 20.1
2. Solder end complies with ANSI B16.18
3. Manufactured in an ISO 9001 Facility

Specifications

Approved pump Isolation flanged valves shall be 2-piece design constructed of brass unibody flange and end cap. Seats shall be Teflon® (PTFE). Stems shall be brass with a Teflon® (PTFE) seat secured with a brass packing gland to adjust handle actuation tension and prevent leakage for the life of the valve. Valve shall be rated 600WOG. The valve shall be a Webstone Company, Inc. Isolator® or Isolator® with drain.

The Isolator® is a registered trademark of Webstone Company Inc.
Teflon® is a registered trademark of Dupont.

THIS SPACE FOR DESIGNER / ENGINEER APPROVAL

Job/Customer _____	Date _____	Contractor _____
Model Specified _____	Qty _____	Approved By _____
Designer/Engineer _____	Date _____	Contractor's PO # _____
Submitted by _____	Date _____	Other _____

1.	FLANGED BODY	BRASS (ASTM B283-C37700)
2.	END CAP	BRASS (ASTM B283-C37700)
3.	SEATS	TEFLON® (PTFE)
4.	BALL	BRASS/HARD CHROME PLATE
5.	STEM	BRASS (ASTM B124-C37700)
6.	STEM SEAL	TEFLON® (PTFE)
7.	PACKING GLAND	BRASS (ASTM B124-C37700)
8.	LEVER HANDLE	C.P. STEEL
8a.	WING STYLE "T" HANDLE	C.P. STEEL/VINYL GRIPS
9.	HANDLE NUT	BRASS (ASTM B124-37700)
10.	HANDLE JACKET	VINYL GRIP
11.	MOUNTING BOLTS AND NUTS	STEEL

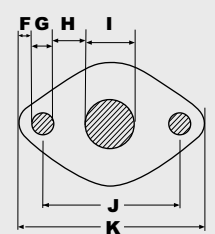
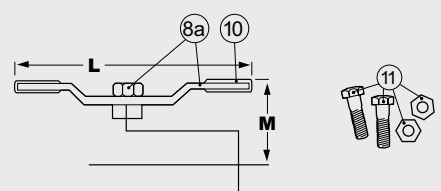
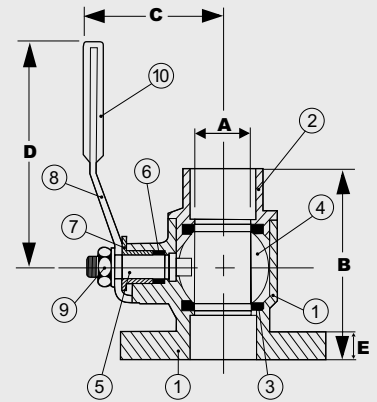

FLANGE FOR HIGH VELOCITY PUMP MODELS
excluding the 2" model

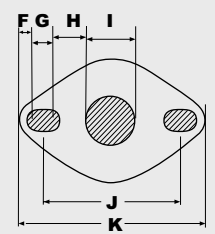

ITEM	SIZE	CTN/CS	A	B	C	D	E	F
50402	1/2	2/20	9/16	2	1 7/8	3 1/2	3/8	3/16
50403	3/4	2/20	3/4	2 3/8	2 1/4	4	3/8	3/16
50404	1	2/20	1	2 3/4	2 1/2	4 5/8	3/8	3/16
50405	1 1/4	2/20	1 1/4	3	2 3/4	4 5/8	3/8	3/16
50406	1 1/2	2/20	1 1/2	3 3/8	3 3/8	5 5/8	1/2	1/8
50407HV	2	2/20	2	3 15/16	3 7/16	5 5/8	1/2	1/8

ITEM	G	H	I	J	K	L	M	C _v
50402	1/2	7/8	13/16	3 3/16	4 1/8	3 1/2	2 1/4	11.47
50403	1/2	3/4	1 1/8	3 3/16	4 1/8	3 15/16	1 15/16	24.01
50404	1/2	5/8	1 5/16	3 3/16	4 1/8	4 1/16	2 1/8	49.30
50405	1/2	1/2	1 5/8	3 3/16	4 1/8	4 1/16	2 1/8	114.03
50406	1/2	5/16	2	3 3/16	4 1/8	4 9/16	2 3/4	161.30
50407HV	1/2	5/8	1 7/8	3 1/2	4 9/16	2 5/16	2 3/4	248.61
HV*	11/16	5/8	1 3/4	3 1/2	4 9/16	*	*	*

* All High Velocity valves share E, F, G, H, I, J, and K measurements.



Call Toll Free: **1-866-711-4673**
WebSales@GoodyearRubberProducts.com

We Ship World Wide