

50443(SET) 50653(HOT), 50663(COLD)

FULL PORT FORGED BRASS TANKLESS WATER HEATER ISOLATION VALVES
IPS UNION x SWT x IPS x HOSE (HOT)
IPS UNION x SWT x HOSE (COLD)
(600 WOG) - ISO 9001



PATENT PENDING

Designed for residential and commercial use to isolate, test and maintain tankless and on-demand hot water heaters. The approved heavy duty forged brass body allows for a full flow throughout the valve and drain & fill connection. Additionally, it meets all requirements set forth in NSF 61-9 for potable water. Both balls are hard chrome plated solid brass and are sealed with reinforced Teflon® seats. These approved Webstone Isolator® EXP™ valves are actuated by blowout proof stems with Teflon® seals that feature adjustable packing glands. A vinyl coated 304 stainless steel handle and an epoxy protected aluminum handle allow for outdoor use. This valve set comes with a hot and cold valve which is depicted by the colored insulator rings on the union connection. The hot water valve features an outlet for a pressure relief valve that will keep the water heater and system protected at all times. Packaged pressure relief valves can be included in the set by adding the appropriate suffix to the item number.

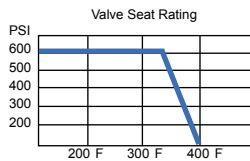
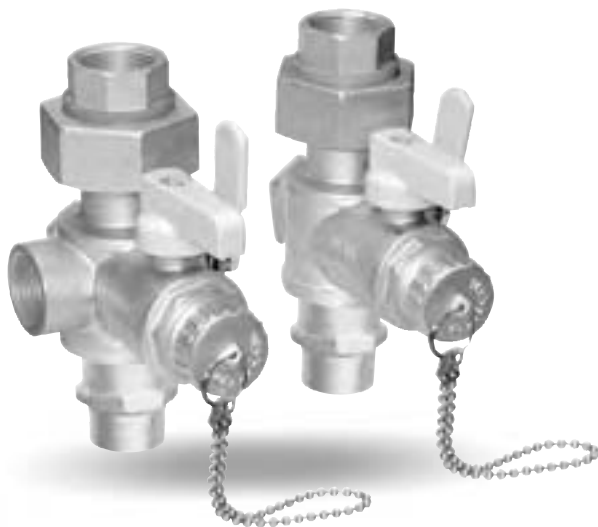

all Teflon® seated valves
 Maximum Temperature is 400°F @ 100 PSI

PRESSURE RATING
 600 WOG non-shock

1. Conforms to NSF 61-9
2. Conforms to Federal Spec. WWV-35C
3. Threaded ends comply with ANSI B1 20.1
4. Teflon® seats withstand temperatures from -40°F to 400°F
5. Manufactured in an ISO 9001 Facility

1.	BODY	FORGED BRASS (ASTM B283-C37700)
2.	END CAP	BRASS (ASTM B283-C37700)
3.	SEATS	TEFLON® (PTFE)
4.	BALL	BRASS/HARD CHROME PLATE
5.	STEM	BRASS (ASTM B124-C37700)
6.	STEM SEAL	TEFLON® (PTFE)
7.	PACKING GLAND	BRASS (ASTM B124-C37700)
8.	HANDLE	SS 304
9.	HANDLE NUT	SS 304
10.	HANDLE JACKET	VINYL GRIP
11.	LOCK WASHER	SS 304
12.	UNION WASHER	NITRATE BUTADIENE (NBR)
13.	UNION INSULATOR	ABS
14.	UNION NUT	BRASS (ASTM B124-C37700)
15.	UNION FITTING	BRASS (ASTM B124-C37700)
16.	RETAINING SEATS	TEFLON® (PTFE)
17.	DRAIN VALVE HANDLE	ENAMEL COATED ALUMINUM
18.	DRAIN VALVE HANDLE SCREW	BRASS (ASTM B124-C37700)
19.	RETAINING NUT	FORGED BRASS (ASTM B283-C37700)
20.	CAP AND CHAIN	BRASS (ASTM B283-C37700) w/NBR HOSE WASHER

HOT

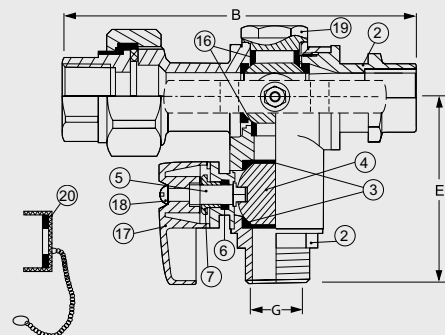
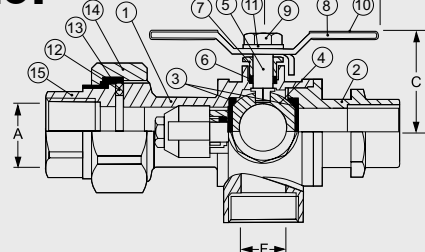

COLD

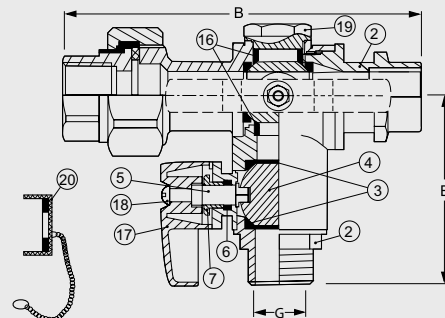
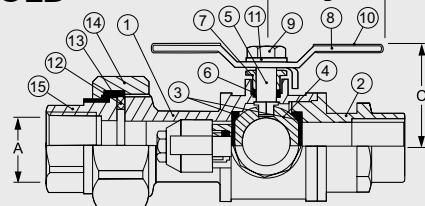

PRESSURE RELIEF VALVE OPTIONS

Valve set includes a pressure relief valve

50443PR
 (150 PSI/200,000 BTU)

50443PR2
 (150 PSI/2,703,000 BTU)

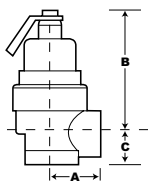
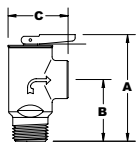

ITEM	SIZE	PSI	BTU	A	B	C
PR	3/4 MIP x FIP	150	200,000	3 5/16	1 3/4	1 7/8

ITEM	SIZE	PSI	BTU	A	B	C
PR2	3/4 FIP	150	2,703,000	1 1/2	3 1/2	1 1/16

The Isolator® is a registered trademark of Webstone Company Inc.
 Teflon® is a registered trademark of Dupont.

THIS SPACE FOR DESIGNER / ENGINEER APPROVAL

Job/Customer _____ Date _____ Contractor _____
 Model Specified _____ Qty _____ Approved By _____
 Designer/Engineer _____ Date _____ Contractor's PO # _____
 Submitted by _____ Date _____ Other _____

ITEM	SIZE	CTN/CS	A	B	C	D	E	F	G
50443	3/4	1/8	3/4	5 1/16	1 1/2	1 13/16	2 7/8	3/4	3/4
50653	3/4	1/20	3/4	5	1 1/2	1 13/16	2 7/8	3/4	3/4
50663	3/4	1/20	3/4	5	1 1/2	1 13/16	2 7/8	-	3/4
50444	1	1/8	1	5 3/8	2 1/8	2	3 5/16	3/4	3/4
50654	1	1/20	1	5 3/8	2 1/8	2	3 5/16	3/4	3/4
50664	1	1/20	1	5 3/8	2 1/8	2	3 5/16	-	3/4