

4040 SERIES

**FULL PORT FORGED BRASS
BALL VALVE - IPS x FLANGE
(600 WOG/150 WSP) - ISO 9001**



EXCLUSIVELY BY WEBSTONE

Designed for residential and commercial use with all 2 bolt flanged circulator pumps. The forged brass body and flange provide strength and versatility for any application where a pipe and flange meet. This approved Webstone valve features a solid hard chrome plated brass ball with reinforced Teflon® seats and a blowout proof stem sealed with Teflon® (PTFE) and an adjustable packing gland. Vinyl coated stamped steel handle. Ideal for use with circulating pumps. The solid brass flange when seated with a rubber gasket eliminates the problem of electrolysis commonly incurred when the use of an iron flange is connected to copper tubing. Additional wing style "T" handle included with mounting nuts and bolts.



Flanges configured for high velocity pumps, add HV as a suffix to the end of the item number. Available in sizes 1" through 2". See G through K dimensions on HV*.

**HIGH VELOCITY
PUMP OPTION**

4040HV SERIES

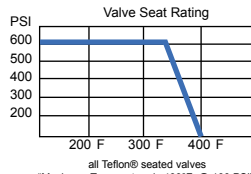

PRESSURE RATING
600 WOG non-shock
150 WSP

1. Threaded ends comply with ANSI B1.20.1
2. Manufactured in an ISO 9001 Facility
3. Approved for use with Propylene

Specifications

Approved pump isolation flanged valves shall be 2-piece design constructed of brass unibody flange and end cap. Seats shall be Teflon® (PTFE). Stems shall be brass with a Teflon® (PTFE) seat secured with a brass packing gland to adjust handle actuation tension and prevent leakage for the life of the valve. Valve shall be rated 600WOG. The valve shall be a Webstone Company, Inc. Isolator® or Isolator® with drain.

The Isolator® is a registered trademark of Webstone Company Inc.
Teflon® is a registered trademark of Dupont.

THIS SPACE FOR DESIGNER / ENGINEER APPROVAL

Job/Customer _____	Date _____	Contractor _____
Model Specified _____	Qty _____	Approved By _____
Designer/Engineer _____	Date _____	Contractor's PO # _____
Submitted by _____	Date _____	Other _____

1.	FLANGED BODY	FORGED BRASS (ASTM B283-C37700)
2.	END CAP	FORGED BRASS (ASTM B283-C37700)
3.	SEATS	TEFLON® (PTFE)
4.	BALL	BRASS/HARD CHROME PLATE
5.	STEM	BRASS (ASTM B124-C37700)
6.	STEM SEAL	TEFLON® (PTFE)
7.	PACKING GLAND	BRASS (ASTM B124-C37700)
8.	LEVER HANDLE	C.P. STEEL
8a.	WING STYLE "T" HANDLE	C.P. STEEL/VINYL GRIPS
9.	HANDLE NUT	BRASS (ASTM B124-37700)
10.	HANDLE JACKET	VINYL GRIP
11.	MOUNTING BOLTS AND NUTS	STEEL

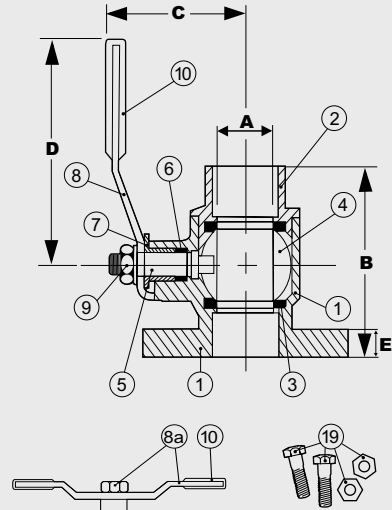

**FLANGE FOR
STANDARD MODELS**

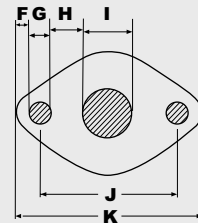

FLANGE FOR HV MODELS

2" model features larger flange and round holes

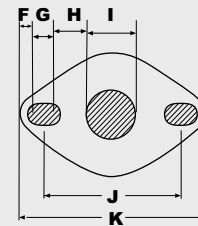

ITEM	SIZE	CTN/CS	A	B	C	D	E
40402	1/2	2/20	9/16	2	1 7/8	3 1/2	3/8
40403	3/4	2/20	3/4	2 1/4	2 1/4	4	3/8
40404	1	2/20	15/16	2 1/2	2 1/2	4 5/8	3/8
40405	1 1/4	2/20	1 1/4	2 13/16	2 3/4	4 5/8	3/8
40406	1 1/2	2/20	1 1/2	3 13/16	3 3/8	5 5/8	3/8
40407HV	2	2/10	2	4 1/4	3 5/8	5 9/16	3/8

ITEM	F	G	H	I	J	K	C _v
40402	3/16	1/2	7/8	13/16	3 3/16	4 1/8	11.47
40403	3/16	1/2	3/4	1 1/8	3 3/16	4 1/8	24.01
40404	3/16	1/2	5/8	1 5/16	3 3/16	4 1/8	49.30
40405	3/16	1/2	1/2	1 5/8	3 3/16	4 1/8	14.03
40406	3/16	1/2	5/16	2	3 3/16	4 1/8	161.30
40407HV	1/8	1/2	5/8	1 7/8	3 1/2	4 9/16	248.61
HV*	1/8	11/16	5/8	1 3/4	3 1/2	4 9/16	N/A

* All High Velocity valves share E, F, G, H, I, J, and K measurements.
C_v - The number of gallons of water per minute that pass through the valve at a 1 lb pressure drop.